

PulsaCoil III

**A mains pressure hot water supply system incorporating
an off peak electric thermal store.**

Design, Installation and Servicing Instructions

**PLEASE LEAVE THESE
INSTRUCTIONS ADJACENT
TO THE APPLIANCE.**

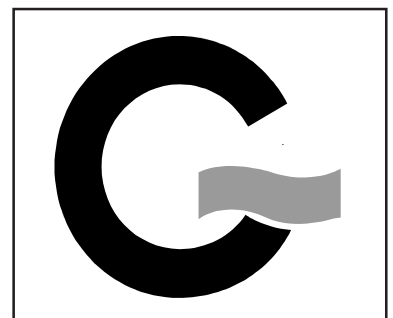

GLEDHILL PULSACOIL III SPECIFICATION

DESCRIPTION	PAGES 1 - 5
SYSTEM DESIGN	PAGES 6 - 8
INSTALLATION	PAGES 9 - 10
COMMISSIONING	PAGE 11
FAULT DIAGNOSTICS	PAGES 12 - 13
SHORT PARTS LIST	PAGE 14 - 15
APPENDIX	PAGE 16
SALES & WARRANTY TERMS	BACK PAGE

Any water distribution systems must be in accordance with the requirements of the regulations and should comply with the relevant recommendations of the British Standards listed below:-

Regulations

- Building Regulations
- Requirements for Electrical Installations BS 7671
- Water Regulations

British Standards

- BS 6700
- BS 7671

The plumbing and electrical work associated with this appliance shall be installed by suitably competent persons. The manufacturer's notes must not be taken as over-riding statutory obligations.

The Pulsacoil III is not covered by section G3 of the 1985 Building Regulations and is therefore not notifiable to Building Control.

Although the domestic water supply to the Pulsacoil III is at mains pressure, it is not necessary to fit an expansion vessel, pressure or temperature relief valve.

The information in this manual is provided to assist generally in the selection of equipment. The responsibility for the selection and specification of our equipment must however remain that of our customer and any designers or consultants concerned with the design and installation.

Please Note: We do not therefore accept any responsibility for matters of design, selection or specification for the effectiveness of an installation containing one of our products.

All goods are sold subject to our Conditions of Sale, which are set out at the rear of this manual.

In the interest of continuously improving the Pulsacoil III range, Gledhill Water Storage Ltd reserve the right to modify the product without notice, and in these circumstances this document, which is accurate at the time of printing, should be disregarded.

The Gledhill Pulsacoil range is a WBS listed product.

THIS PRODUCT IS MANUFACTURED UNDER A BS EN ISO 9002 QUALITY SYSTEM AUDITED BY BSI.

DESCRIPTION

INTRODUCTION

The PulsaCoil III based hot water supply system is shown schematically in Figure 1.1.

The PulsaCoil III appliance utilizes an off peak electrically heated thermal store with integral feed and expansion cistern to produce primary hot water. This is then circulated by a pump through a plate heat exchanger to instantaneously heat mains pressure domestic cold water. This allows mains pressure domestic hot water to be provided to the taps at high flow rates without the need for any temperature and pressure relief safety valves or expansion vessels. The actual temperature of the domestic hot water is maintained at the pre-set level by a printed circuit board which controls the speed of the pump circulating the primary hot water from the store through the plate heat exchanger.

THERMAL STORE

The thermal store and the top up cistern are constructed of copper. The thermal store is manually filled with mains cold water through the feed and expansion cistern. It should be filled up to the level of the swage mark in the cistern.

The thermal store is efficiently insulated with Rockwool CFC free insulation and finished in a painted steel case to minimise standing losses.

The primary water in the store is heated to a temperature of approximately 77°C by the immersion heaters.

DOMESTIC HOT WATER

Cold Water Supply

The PulsaCoil III units are designed to be fed directly from the mains water supply as shown schematically in Figure 1.1. They fulfil the requirements of Water Bylaw 91, and therefore do not require a check valve to be fitted to the supply pipe. The performance of the PulsaCoil is directly related to the adequacy of the cold water supply to the dwelling. This must be capable of providing for those services, which could be required to be supplied simultaneously, and this maximum demand should be calculated using procedures defined in BS 6700. PulsaCoil will operate at mains pressures as low as 1 bar and this must be available when the local demand is at its maximum, but the preferred range is between 2 and 3 bar. As a general guideline, although a 15mm external service may be sufficient for smaller dwellings with one bathroom, a 22mm service (25mm MDPE) is preferred and should be the minimum for larger dwellings. If a water meter is fitted in the service pipe, it should have a nominal rating to match the maximum hot and cold water peak demand calculated in accordance with BS 6700. This could be up to 50 litres/min in some properties.

The unit must be fitted strictly in accordance with the requirements of the Local Water Undertaking who should be consulted prior to the installation. In the event of any difficulty please contact us as the manufacturers. The equipment used in the system should be suitable for a working pressure of 8 bar and approved by the WBS or other relevant standard. If this is not the case a pressure limiting valve will be required which is suitable for the item of equipment with the lowest maximum working pressure.

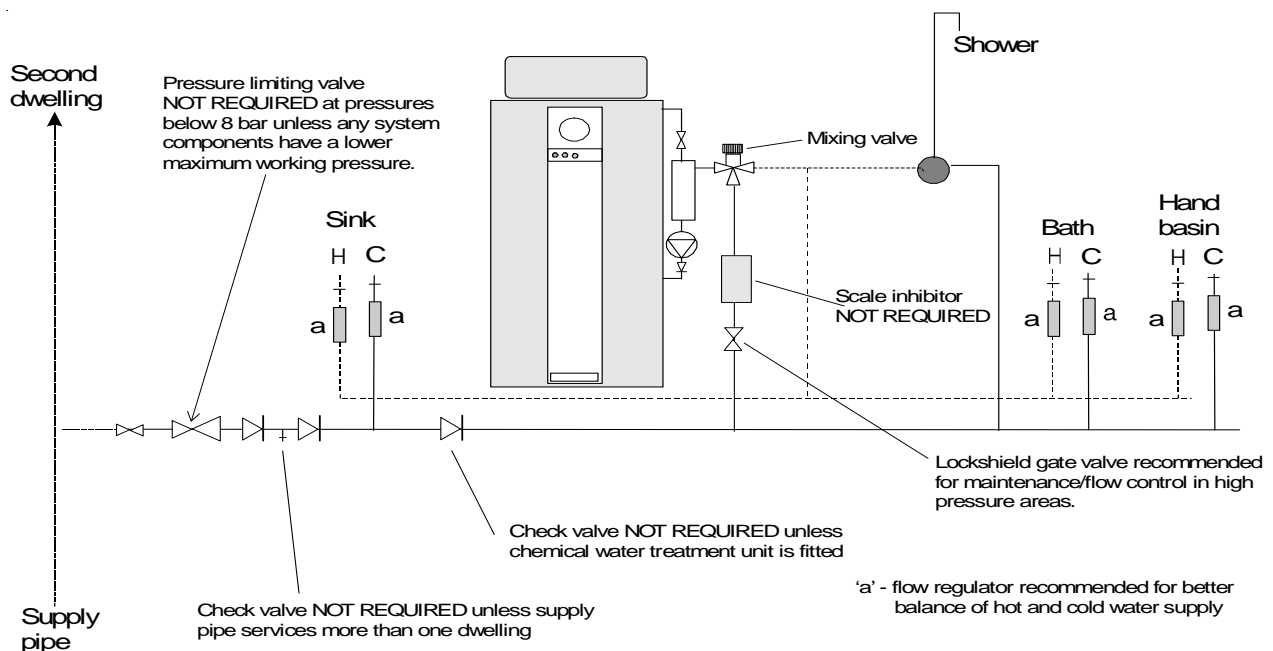

Figure 1.1 Typical hot and cold water distribution network

Safety Fittings

It is not necessary to fit control and safety equipment normally associated with mains pressure hot water storage appliances e.g. temperature and pressure relief valves and expansion vessel. PulsaCoil is WBS listed and a non-return valve is not required. However if the ancillary equipment fitted in the supply to these appliances require a non-return valve then the valve must be fitted directly after the branch to the drinking water i.e. a kitchen sink as shown schematically in Figure 1.1.

Domestic Hot Water Flow Rates

Provided the pipe sizing and the supply pressure is adequate the hot water flow rate should be up to 35 litres/min for all models (see Table 1.1). The domestic hot water outlet temperature is regulated to 55°C by the electronic control system and is not user adjustable.

Use in Hard Water Areas

There are two options for the pump speed control. Option 'H' must be used in hard water areas above 200ppm. Option 'S' can be used in soft water areas below 200ppm.

A patented control system within the Option 'H' microprocessor offers a more sophisticated level of pump speed control and will help prevent the formation of scale.

Both options ('H' and 'S') prevent domestic hot water from exceeding 55°C for most of the operational times of the appliance.

It is not necessary to fit any form of scale inhibiting equipment in the domestic cold water supply to the PulsaCoil when using option 'H'.

If scale should however become a problem the plate heat exchanger is easily isolated and can be replaced with a service exchange unit.

DESCRIPTION

STANDARD EQUIPMENT

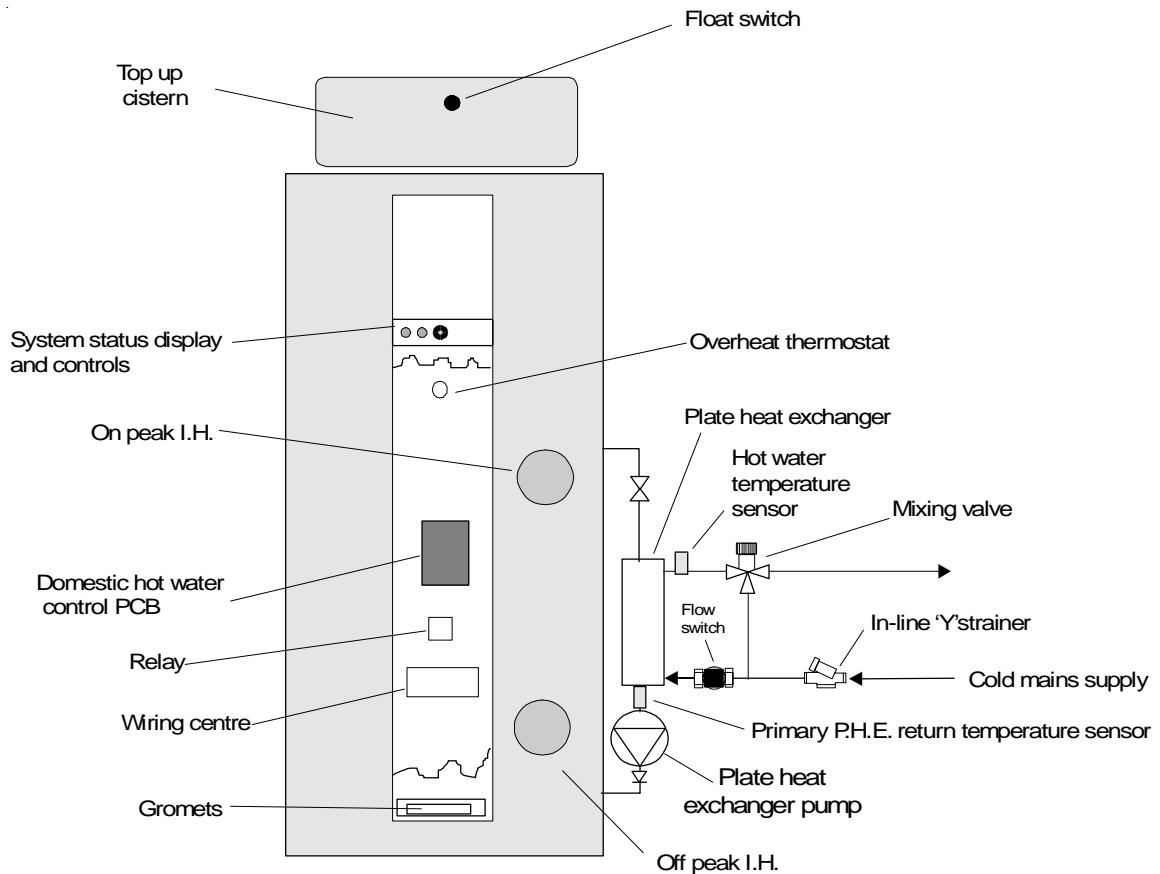

Figure 1.2 Standard PulsaCoil III Package

The standard configuration of the PulsaCoil III is shown in Figure 1.2. It is supplied as a complete factory made and tested appliance fitted with all the following items of equipment :-

- Grundfos UPS pump for domestic hot water primary circuit.
- Domestic hot water temperature controls and PCB.
- 2 x 3 kW low watts density Incaloy immersion heaters.
- Domestic hot water plate heat exchanger.
- Domestic hot water mixing valve.
- Float switch for 'Dry Firing' protection.
- Overheat protection.
- Wiring centre.
- System status display.

OPTIONAL EQUIPMENT

a) The appliance is supplied with the components on the right hand side (as shown in Figure 1.2) as standard but can be supplied left handed.

b) A 22mm diameter warning pipe/overflow connection. Any options must be clearly specified at the time of order or a standard model will be supplied.

ELECTRIC IMMERSION HEATERS

The immersion heaters used are 14" 3kW low watts density units with incaloy 825 immersion sheaths, and matching 11" rod thermostats which should be set to 77°C. They are BEAB approved and have been chosen to meet the requirements of the Maxistore specification produced specially for Economy 7 products by the Electricity Industry.

It is recommended that replacements should be obtained only from Gledhill Water Storage.

Table 1.1 Technical Specification of PulsaCoil III

MODEL	PC144	PC190	PC210	PC245
Overall dimensions of store (Height x Diameter)	1650 x 525	1840 x 550	1840 x 575	1960 x 575
Minimum cupboard size (Width x Depth)	700 x 550	715 x 600	750 x 650	750 x 650
Nominal store capacity (litres)	160	205	230	250
Weight (kg)				
• Empty	39	41	46	52
• Full	199	246	276	302
Hot water flow rate (litres/min)	35	35	35	35
Typical dwelling types				
• Bedrooms	1 - 2	2 - 3	2 - 3	2 - 4
• Bathrooms	1 or	1	1	2
• En-suite shower rooms	1	1	2	1

NOTES

1. The PC245 model can be installed in a property with greater hot water demand. However this will require more 'ON peak' electricity to recharge the store.
2. The standard pattern is manual fill. If automatic fill patterns are required please speak to our Technical Sales Office.
3. The flow rates are for 35°C average temperature rise and assume normal pressure and adequate flow to the appliance.
4. For hard water areas use suffix 'H', for soft water areas use suffix 'S' after the model number, e.g. PC144H = PulsaCoil mk III model 144 for hard water areas.
5. A minimum of 200mm should be available above the appliance to allow it to be filled and the water level checked.

SYSTEM DESIGN

HOT AND COLD WATER SERVICES

A schematic layout of the hot and cold water services in a typical small dwelling is shown in Figure 2.1.

PulsaCoil III will operate at mains pressures as low as 1 bar and as high as 8 bar although the preferred range is 2-3 bar. It is also important to check that all other equipment and components in the hot and cold water system are capable of accepting the mains pressure available to the property.

If the mains pressure can rise above the maximum working pressure of any items of equipment or component to be fitted a suitable pressure limiting (reducing) valve will be required.

For properties with a higher supply pressure than 8 bar it is recommended that a pressure limiting valve is fitted, set at 3 bar.

PulsaCoil III is WBS approved. A non-return valve is not required. Should ancillary equipment fitted in the supply to the PulsaCoil require a non-return valve, then this valve must be fitted directly after the branch to the drinking water tap (kitchen sink). See Figure 1.1 for details.

Note: The hot and cold water distribution pipework should be designed and installed to prevent heating of the cold distribution pipe.

Taps and Valves

Aerated taps are recommended for all mains pressure systems to prevent splashing.

Pipe Sizing

To achieve even distribution of the available supply of hot and cold water, it is important in any mains pressure system that the distribution pipes in a dwelling should be sized in accordance with BS6700. This is particularly important in a large property or one with more than one bathroom. However the following rule of thumb guide lines should be adequate for most typical property types:

- a) A 15mm copper or equivalent external service may be sufficient for smaller 1 bathroom dwellings (depending upon the flow rate available), but the minimum size for larger dwellings must be 22mm (25mm MDPE).
- b) The internal cold feed from the main stop tap to the PulsaCoil should be run in 22mm pipe. The hot draw-off should also be run in 22mm as far as the branch to the bath tap.
- c) The final branches to the hand basins and sinks should be in 10mm and to the shower in 15mm.
- d) The final branches to taps in existing properties, which are in 15mm, **should be restricted** to balance the flow to each outlet.

- e) Best results for a balanced system are achieved by fitting appropriate flow regulators to each hot and cold outlet (see Appendix 1).
- f) For properties where the inlet pressure is high and the flow rates may exceed 30 l/min at any bath hot tap the installer must fit a lockshield pattern gate valve at the cold inlet to the appliance. This should then be adjusted to restrict the maximum flow rate to 30 l/min.

On the odd occasion it is felt necessary to provide a secondary circulation. We would recommend the use of Raychem HWAT Plus or similar self regulating trace heating to maintain the temperature in the hot water distribution system. The system must be installed and commissioned fully in accordance with the manufacturers instructions.

Showers

- a) Any type of shower mixing valve can be used as long as both the hot and cold supplies are mains fed. However **PRESSURE COMPENSATING** shower mixing valves are proven to give better control when more than one fitting are open simultaneously and are therefore **STRONGLY RECOMMENDED**. Thermostatic versions are preferable.
- b) The hot water supply to a shower mixing valve should, wherever practical, be fed directly from the PulsaCoil III or be the first draw-off point on the hot circuit.
- c) The cold supply to a shower mixing valve should be fed directly from the rising mains via an independent branch.
- d) **Fixed head type showers:** No back-syphonage arrangements are necessary.
- e) **Loose or flexible head type showers:** If a loose head shower with a flexible hose is used over a bath then:
 - The hose must be fixed so that the head cannot fall closer than 25mm above the top edge of the bath as specified in Model Byelaw 16 of the Water Supply Byelaws.Or
 - The shower must incorporate or be fitted with an acceptable means of back-syphonage protection in accordance with the Model Water Byelaws.

Bidets

- a) The supply of hot and cold mains water directly to a bidet is permitted provided that it is of the over-rim flushing type and that a type 'A' air gap is incorporated.
- b) It must not include either an ascending spray or provision to attach a hand spray.

Plumbing

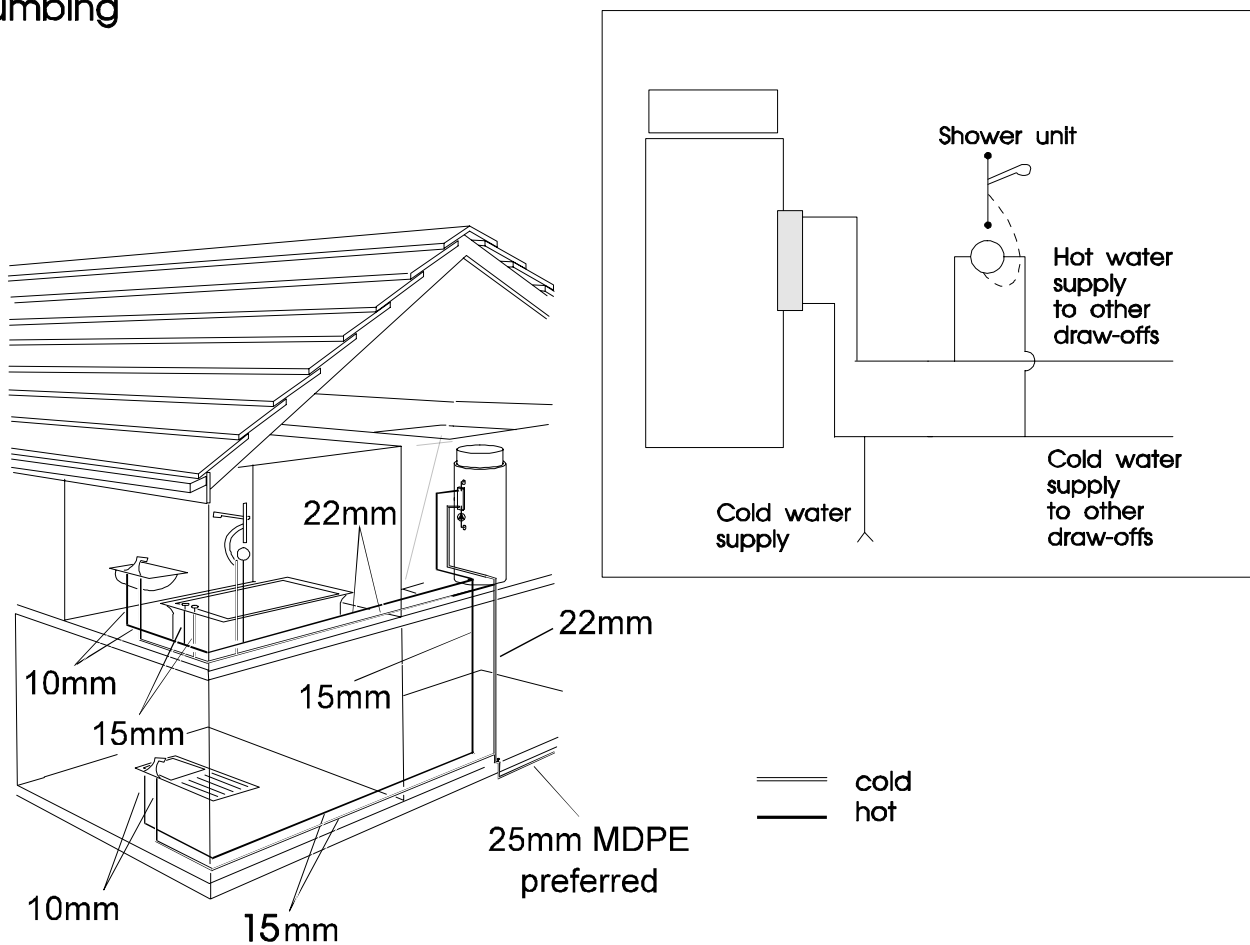

Fig 2.1 Schematic layout of typical domestic hot & cold water systems.

Plastic Pipework

This appliance is suitable for use with plastic pipework as long as the material is recommended for the purpose by the manufacturer and is installed fully in accordance with their recommendations.

We recommend the use of barrier pipe, which will mean the system can have BritishGas service cover in regions offering this service.

WIRING THE SYSTEM

The whole of the electrical installation shall be designed by a competent person fully in accordance with the latest edition of the Requirements for Electrical Installations BS 7671.

However, the following guidance is provided to show the general principles involved.

The PulsaCoil III appliance is provided with two side entry immersion heaters. The lower element is connected to the off peak supply and enables the whole of the contents to be heated overnight using a low cost tariff.

The upper element is connected to the unrestricted supply and enables the upper part of the contents to be given a day time boost. This is switched manually or by a timer and uses the standard tariff. In some areas the local electricity company allows a limited day time off peak boost.

It is normal to supply the PulsaCoil III using an Economy 7 controller as shown in Figure 2.2.

Alternatively the PulsaCoil III can be supplied from separate circuits as shown in Figure 2.3. In this case the two switches should be clearly labelled for the householders use.

In addition to the supplies to the immersion heaters, PulsaCoil III requires a 3 amp supply for the control circuit. This 3 amp supply must be provided via a fused 3 amp double pole isolator providing 3mm of separation to both poles.

SYSTEM DESIGN

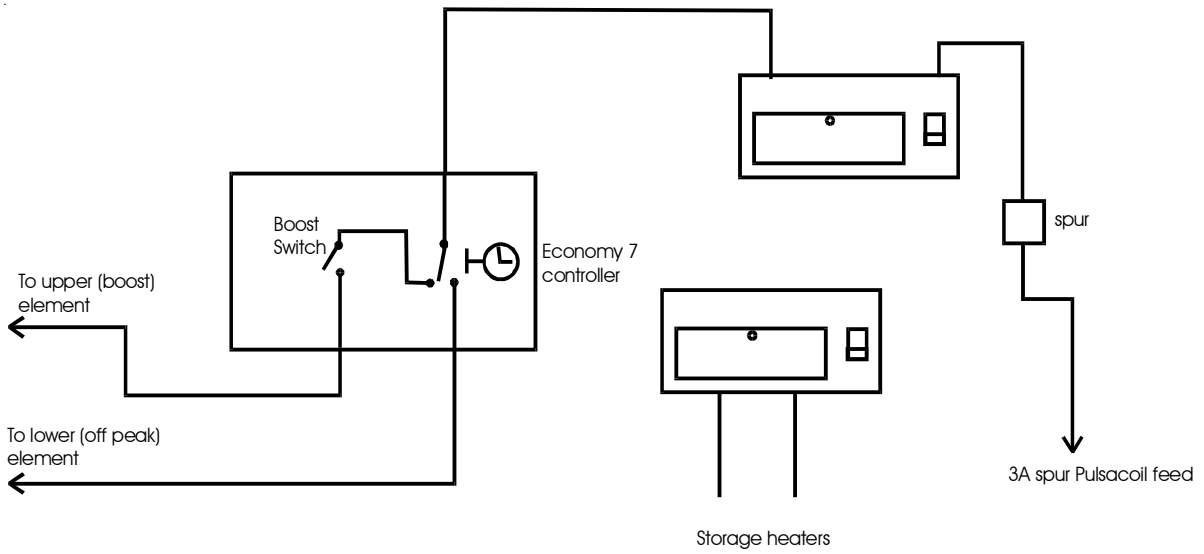

Figure 2.2 Economy 7 controller

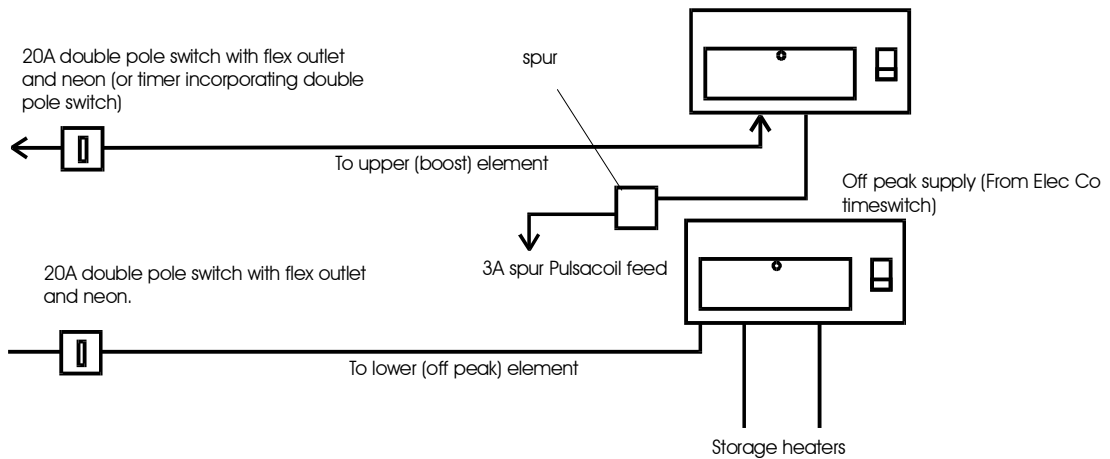

Figure 2.3 separate circuits

In addition to the supplies to the immersion heaters, PulsaCoil III requires a 3 amp supply for the control circuit. This 3 amp supply must be provided via a fused 3 amp double pole isolator providing 3mm of separation to both poles.

INSTALLATION

INSTALLATION INSTRUCTIONS

Important Notes

It is important that the appliance is installed on a level and even floor or if raised above the base should be continuously supported. If the support is timber, it shall be marine ply, type C4 chipboard to B.S.5669 or other material which will not deteriorate if exposed to moisture. Details of the appliance weight when full is provided in Table 1.1 of technical specifications.

Plumbing Connections

- Before installation it should be confirmed that a minimum 1 bar mains water pressure under flow conditions is available.
- Make all water connections in accordance with the labelling on the thermal store and the associated pipework as shown in Figure 3.1.
- Install the domestic hot and cold water pipework generally as described under System Design and as shown in Figure 1.1.
- All factory made joints should be checked after installation in case they have been loosened during transit.
- Ensure that the DHW pipework is run such that it does not heat the cold water distribution pipes in the dwelling.

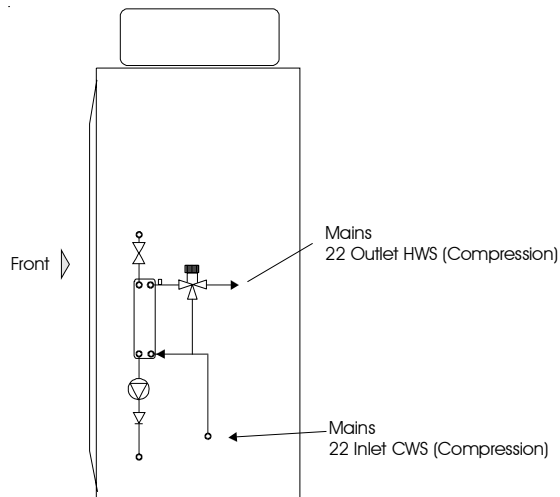

Fig 3.1 Pulsacoil III pipe connection arrangement

THERMAL STORE FEED AND EXPANSION CISTERN

It is most important to fill with cold water so that the water level is in line with the mark on the inside of the feed and expansion cistern. This allows adequate room for expansion.

Overflow/Warning Pipe (if fitted)

- The overflow warning pipe should be fitted to discharge clear of the building and be sited so that any overflow can be easily observed.
- The overflow/warning pipe should be installed in a material suitable for use with heating feed and expansion cisterns in accordance with BS5449 (such as copper) and should not have any other connections to it.

PUMP SETTINGS/ REPLACEMENT

The domestic hot water plate heat exchanger pump should always be set at maximum speed.

If it is necessary to replace the pump fitted to the appliance the pump head (motor pack) only should be removed as recommended by the manufacturer (Grundfos). Assuming it is within warranty this will be accepted by a merchant as being under warranty as long as a complete pump i.e. alleged faulty motor pack and new base is left with the merchant. It is important when a pump has been replaced to ensure that any air is adequately vented

DOMESTIC HOT WATER TEMPERATURE

The electronic system automatically regulates the domestic hot water outlet temperature to 55°C and no adjustment or setting is necessary during installation.

CUPBOARD DETAILS

a) Minimum cupboard sizes are shown in Table 1.1 and it is important to check that these are available prior to installation.

b) It is recommended that any surface mounted heating and hot and cold water supply pipework in the Pulsacoil III cupboard must be insulated to reduce the standing losses and to prevent unnecessarily high cupboard temperatures. More heat is lost from the first metre of pipework connected to the store than from the store.

NOTE: It is a requirement of Part L of the Building Regulations that all hot water pipework within 1 metre of a hot water appliance is insulated.

c) Notwithstanding the above, the cupboard temperatures are normally higher than in a conventional system and therefore the design of both the cupboard and the door should take this into account.

INSTALLATION

WIRING THE APPLIANCE

The whole of the electrical installation shall be installed by a competent person fully in accordance with the latest edition of the Requirements for Electrical Installations BS 7671.

The PulsaCoil III is pre-wired back to a wiring centre (see Figure 3.2) and a plumber should be able to connect the appliance provided they adhere strictly to the recommendations and the IEE Regulations. However, do not attempt the electrical work unless you are competent to carry it out to these standards.

Before commencing, ensure that all the power sources to which the PulsaCoil III is to be connected are isolated and properly earthed.

See Figure 3.2 for details of the wiring within the appliance.

Connect the external wiring as follows

- Remove the white cover plate (4 screws) and run the external wiring through the grommets provided in the fixed white panel at the base of the appliance.
- From the 3A fused and switched connection, wire the mains power supply to the control circuit terminal block as follows:-
 - Live to terminal 1
 - Neutral to terminal 2
 - Earth to terminal 3
- From the Economy 7 controller (or separate 20A fuse and switch connections), wire the mains power supply to the immersion heater terminal block as follows:-
 - Unrestricted (on peak) live to terminal 5 (L1)
 - Unrestricted neutral to terminal 6
 - Unrestricted earth to terminal 7
 - Off peak live to terminal 8 (L2)
 - Off peak neutral to terminal 9
 - Off peak earth to terminal 10
- When the wiring is complete replace the front white cover plate (4 screws).

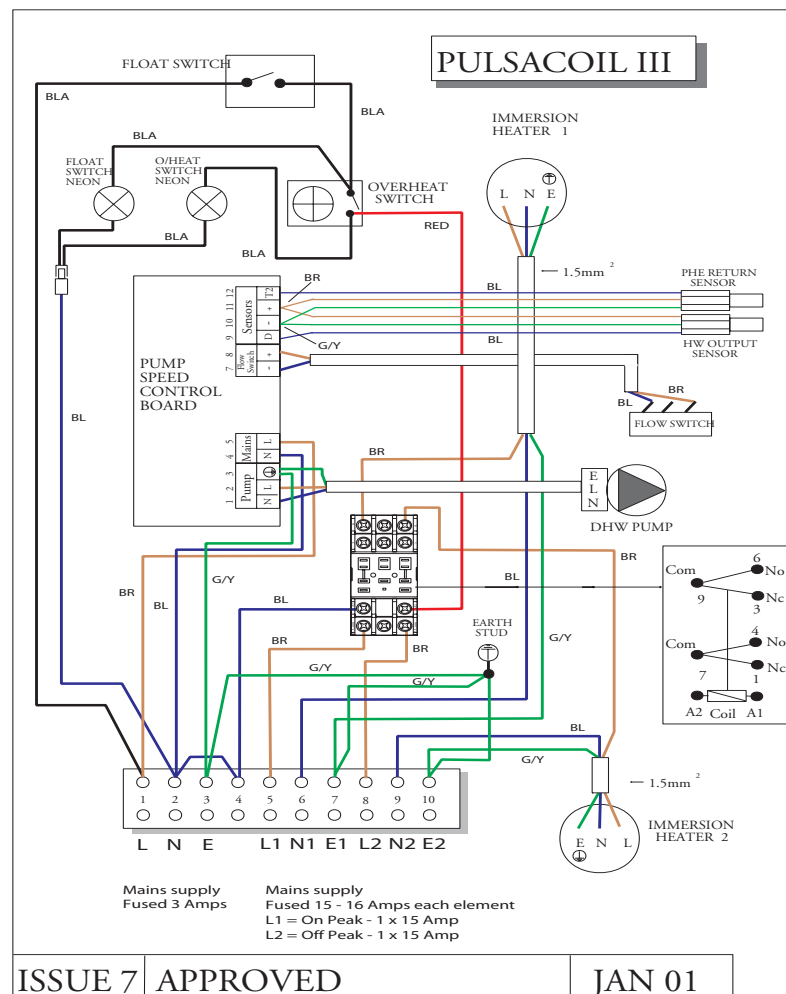

Figure 3.2 Wiring Details

COMMISSIONING

COMMISSIONING

It is essential that the operation and performance of the appliance and the domestic water systems are proven on completion of the installation.

COMMISSIONING THE DOMESTIC WATER SYSTEMS

The system shall be filled, flushed and sterilised in accordance with the requirements of BS 6700 and the Model Water Byelaws.

The flow rate from each tap shall also be checked and a suitable number of taps run simultaneously to check the impact of this on the flow rate at individual taps.

We do recommend that flow restrictors are provided on the branch to each tap/terminal fitting to ensure that the available flow is shared evenly - see Appendix for details.

COMMISSIONING THE APPLIANCE

The PulsaCoil III shall be filled with mains cold water through the F and E cistern lid until the level is in line with the swage mark provided in the cistern. The lid shall be replaced.

Once the PulsaCoil III is filled with water the electrical supplies can be switched on.

The control panel on the front of the appliance is provided with two green indicator lights and a reset button as follows:-

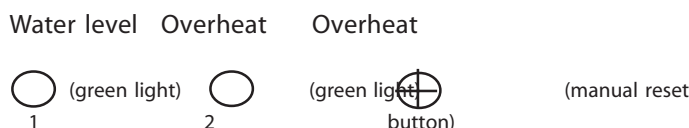

Green light No.1 is linked to the flow switch and should be 'on' to show there is sufficient water in the F and E cistern.

Green light No.2 is linked to the overheat thermostat and should be 'on' to indicate the system is functioning correctly.

The overheat button should be 'pressed in'.

If this is the case the immersion heaters should be allowed to bring the contents up to temperature. Check that the thermostats do switch off at the correct temperature of 77°C. If not the seal can be broken and the setting adjusted without affecting the warranty.

If the thermostats do not switch off the immersion heaters at the correct temperature the overheat thermostat will operate the overheat manual reset button. In this case check and adjust the immersion heater thermostats or replace if necessary and reset the overheat button.

Once the immersion heaters have switched off run a tap and check that the temperature of the hot water is about 55°C. This temperature is factory set and is independent of the store temperature and hot water flow rates.

IMPORTANT DO'S AND DON'TS

- DO** check the incoming mains water pressure. The preferred range of mains pressure is 2 – 3 bar.
- DO** check the flow rate of the incoming cold water main is adequate to meet the maximum hot and cold water simultaneous demands.
- DO** check that all connections are in accordance with the labelling on the thermal store.
- DO** check the water level is correctly set in the F & E cistern when cold and adjust if necessary.
- DO** ensure that the immersion heater thermostats are set to 77°C.
- DO** insulate any exposed pipework in the PulsaCoil cupboard.
- If provided **DO** plumb the overflow/warning pipe in a 20mm internal diameter pipe and ensure it discharges in a conspicuous external position. Use a material which is suitable for use with heating F & E cisterns in accordance with BS 5449 (such as copper).
- DO** ensure the 2 green lights are 'on' and the manual overheat reset button is pushed in.

FAULT FINDING/DIAGNOSTICS

FAULT DIAGNOSTICS

The control panel on the front of the appliance is provided with 2 green indicator lights and a manual reset button.

○ (Green light) ○ (Green light) ⊕ (manual reset button)

These are provided to indicate the following:-

GREEN LIGHT NO.1

Will sense the water level within the F & E cistern and will prevent the immersion heaters from being switched 'ON' when the unit is not full of water.

Green light No.1 will remain 'ON' to indicate that the system is functioning correctly and is filled with water to the correct level. If both Green lights 1 & 2 are 'OFF' check the water level in the F & E cistern. If the water level is correct check the unit is switched 'ON'.

GREEN LIGHT NO.2 & MANUAL RESET BUTTON

Will provide overheat protection to prevent the stored water from boiling in the event of immersion heater thermostat failure. Green light No.2 will remain 'ON' to indicate that the system is functioning correctly. If Green light No.2 is 'OFF' check the manual reset button on the overheat thermostat. If the overheat button has popped out check and replace as necessary the immersion heater thermostats. The thermostats must be set at 77°C. Manually press the reset button on the overheat thermostat to reset the appliance.

FAULT FINDING

FAULT CONDITION	POSSIBLE CAUSES
DHW temperature remains cold exiting the taps.	Thermal store is cold - DHW pump is stuck - DHW temperature sensor or pump speed control PCB is faulty - too little or too much flow from the pipe.
DHW temperature fluctuates wildly when flow is steady.	DHW pump keeps sticking when voltage is reduced and not starting until voltage is too high.
DHW temperature exceeds and remains well above 60°C when the flow rate is low.	DHW pump speed control PCB and/or temperature sensor is/are faulty.

FAULT FINDINGS

FAULT FINDING

A number of the DHW faults indicated in the above chart will be indicated by the pump speed control PCB.

The layout of the pump speed control PCB is shown in the figure below. In faulty conditions if the hot water outlet temperature exceeds 60°C, the pump speed will be reduced to minimum and if the outlet temperature exceeds 65°C, the pump will be switched off until the outlet temperature reduces to 50°C.

Jumpers

1 - Off

2 - Off

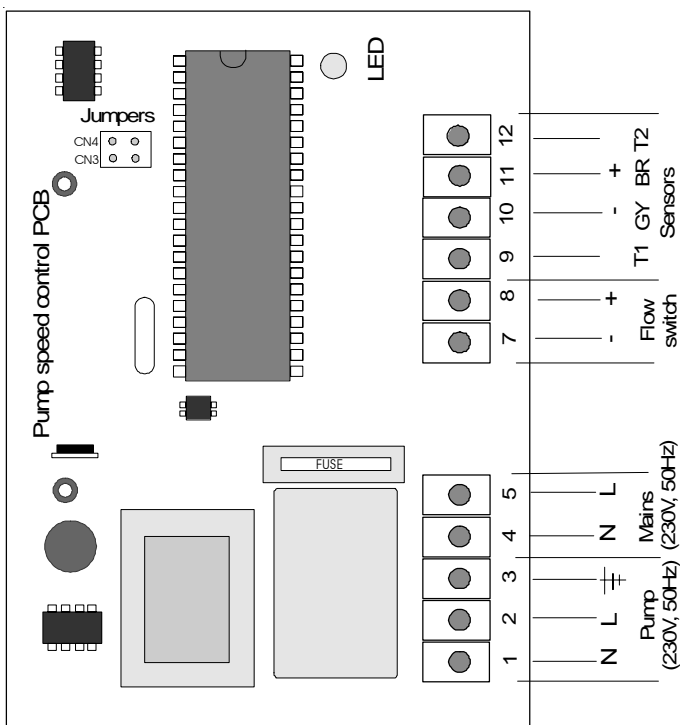

The LED will operate in the following way to show fault conditions:-

- Off: No mains power supply - check fuse
- Flashing - Low frequency System status is OK
- Flashing - High frequency Temperature measurement error - faulty sensor or wiring
- On - Permanent Processor related fault - no control of hot water - replace PCB

MAINTENANCE

No annual/regular maintenance is required. However, with the manual fill model we do recommend that the water level in the top up cistern is checked periodically and water added if required. Particularly if the cistern lid has been removed.

PARTS LIST

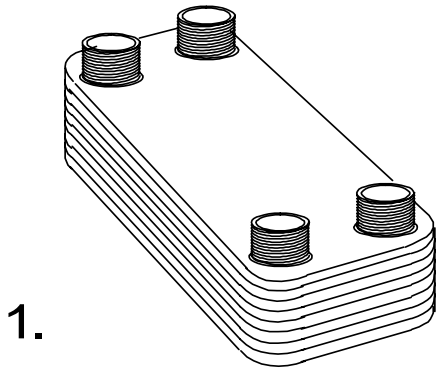

1.

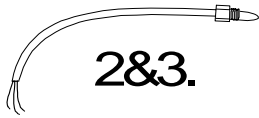

2&3.

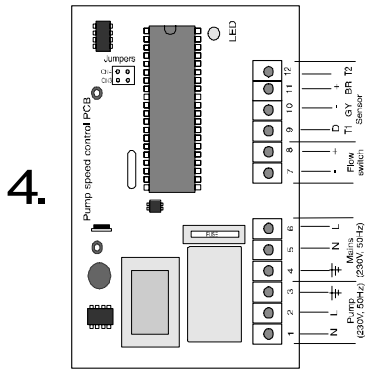

4.

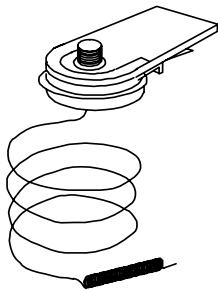

6.

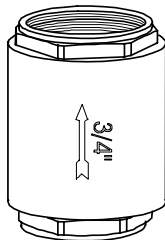

7.

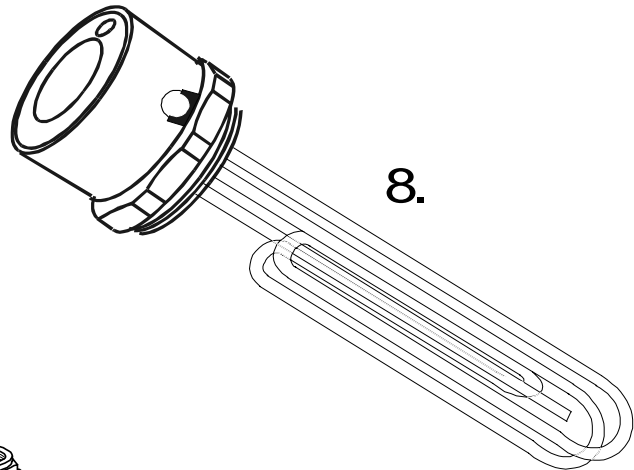

8.

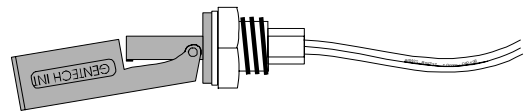

10.

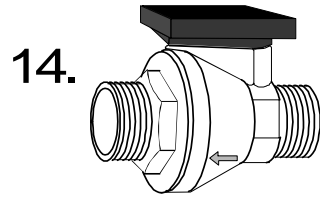

14.

To Reduce Temp

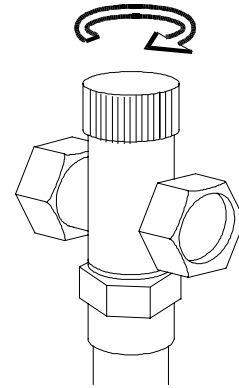

13. Brawa Mixing valve

PARTS LIST

KEY NO	DESCRIPTION	G.C. NUMBER	PART NO.
1	DHW plate heat exchanger	E05-664	GT017
2	PHE return temperature sensor	E26-022	GT149
3	DHW temp sensor	E26-024	GT153
4	DHW pump speed control PCB	E26-023	GT152
5	DHW pump	E05-723	GT105
6	Store overheat thermostat	397-978	GT064
7	Gravity check valve	E05-681	GT041
8	Immersion heater	E39-184	XB078
9	Rod thermostat	E39-185	XB501
10	Float switch	E39-186	XB251
11	Relay	E39-187	XB321
12	Green light (neon)	E39-190	XB100
13	Brawa mixing valve	385-872	XC007
14	DHW Flow switch	E05-674	GT106

APPENDIX

WATER SAVINGS

WATER RELATED COSTS CAN BE REDUCED BY GOOD PLUMBING PRACTICE.

TAPS & MIXERS

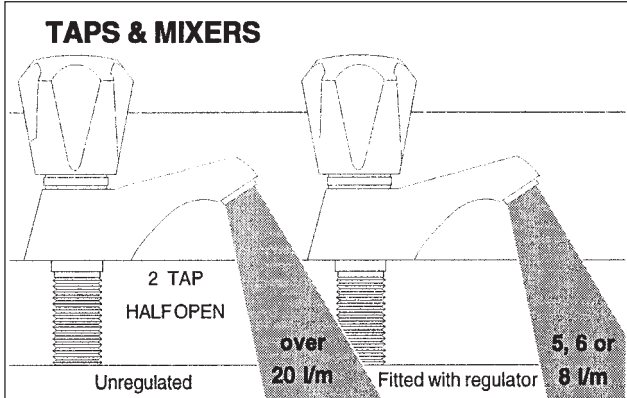

SHOWERS

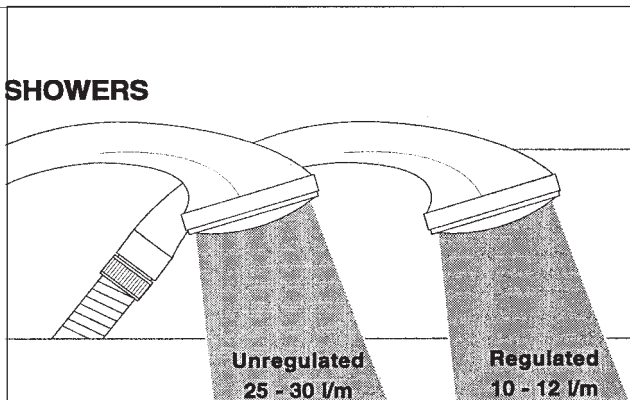

Vast quantities of water are needlessly run off to waste due to Taps, Mixers and Showers discharging flow rates far in excess of the rates required for them to perform their duties.

The contrasting flow rates shown on this leaflet clearly illustrate the savings that can be made whilst still providing a good performance.

British made AQUAFLOW REGULATORS provide constant flow rates by automatically compensating for supply pressure changes between 1 bar & 10 bars.

To facilitate installation into the wide range of plumbing equipment which is encountered in the U.K, FOUR FIXING OPTIONS are available:-

OPTIONS FOR SHOWERS

1. MXF "DW" RANGE - For fitting behind Fixed Shower Heads or onto Flexible Hoses for Handshowers (preferably onto the inlet end when lightweight hoses are used).
2. COMPRESSION FITTING RANGE. "In Line" regulators as in Option 4 for Taps & Mixers.

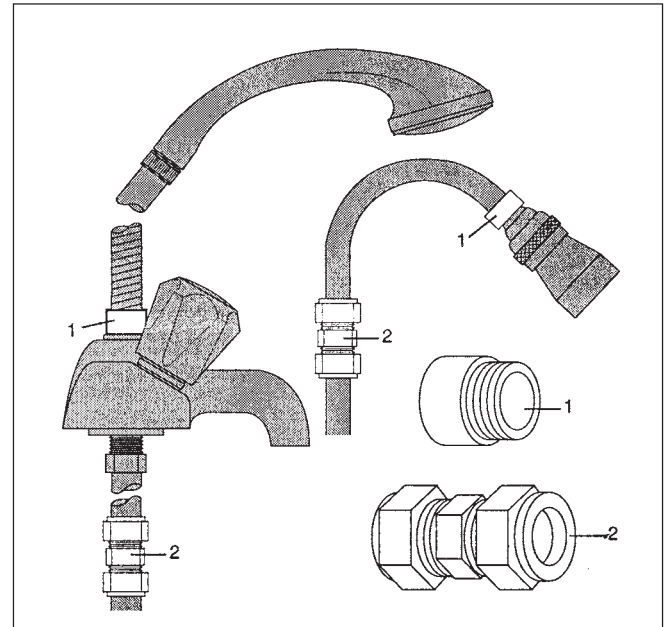

4 FIXING OPTIONS FOR TAPS & MIXERS

1. MK RANGE - Combined Regulators & Aerators for screwing onto Taps & Mixers with internal or external threads on their noses. Anti Vandal models also available.
2. MR05-T RANGE - Internal Regulators. Push fit into Tap or Mixer seats. Produced in three sizes - 12.5mm (BS1010), 12mm & 10mm, Flangeless models also available for Taps with Low Lift washers.
3. MXF STANDARD RANGE - Screw on tail models for Taps & Mixers. Fix onto the tails before fitting the tap connectors. Available in 3/8", 1/2", 3/4" and 1" BSP.
4. COMPRESSION FITTING RANGE - "In Line" regulators housed in 15mm & 22mm CXC COUPLERS & ISOLATING VALVES. " " UK WFBs LISTED BY THE WATER RESEARCH CENTRE. Isolation valves available for slotted screwdriver operation or with coloured plastic handles. Now available also in plastic bodied push-fit couplers & valves.

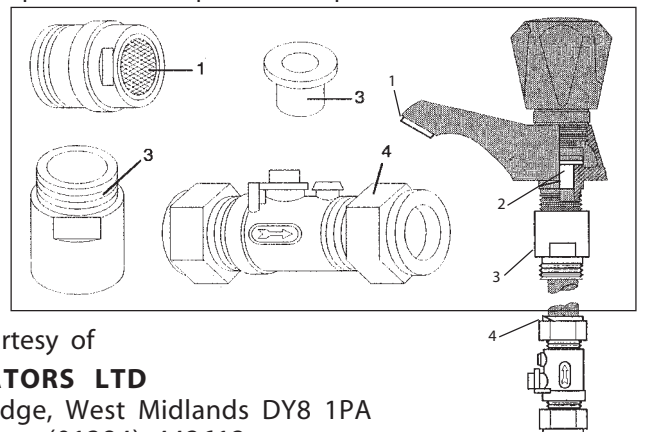

Information by courtesy of

AQUAFLOW REGULATORS LTD

Haywood House, 40 New Road, Stourbridge, West Midlands DY8 1PA
Telephone (01384) 442611 Fax: (01384) 442612

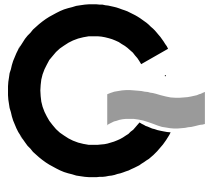

1. We only do business upon the Conditions which appear below and no other. Unless we so agree in writing these Conditions shall apply in full to any supply of goods by us to the exclusion of any Conditions or terms sought to be imposed by any purchaser. These Conditions of Sale and Warranty Terms override those which are contained on the Invoice Forms and all Sales are now subject to these Conditions of Sale and Warranty terms only.

2. PRICE

Orders are accepted at the price ruling at the date of receipt of order, this price is our last published list price plus a supplement to allow for any increase in the price of copper between the dates of publication of our price lists ("the copper price supplement"). An order may not be cancelled or varied after acceptance without the written consent of the company. Such cancellation or variation shall be subject to such reasonable charges as may be appropriate.

3. SPECIFICATION

The goods are supplied in accordance with the Specifications (if any) submitted to the Purchaser and any additions and alterations shall be the subject of an extra charge. Any goods not so specified shall be in accordance with our printed literature or the literature of any of our component suppliers (subject to any modifications made since publication). If we adopt any changes in construction or design of the goods, or in the specification printed in our literature, the Purchaser shall accept the goods so changed in fulfilment of the order.

4. PAYMENT

The invoice price of goods shall be payable within 30 days of despatch by us of our invoice for the goods or such longer time as may be stated by our quotation or invoice. If we receive payment in full on or before the due date we will allow a discount of 5% except where we have quoted a special net price. If payment is not received in full on or before the due date we shall be entitled in addition to the invoice price to:

- (i) payment of a sum equal to any increase in the copper price supplement applicable to the particular goods sold between the date of receipt of order and the date of receipt of payment in full; and
- (ii) interest on any part of the invoice price unpaid after the due date at the rate of 3% per annum over the base rate for the time being of Midland Bank plc.

5. TIME

We give estimates of delivery dates in good faith and time of delivery is not nor shall be made of the essence of any contract nor shall we be liable for any loss or damage occasioned by delay in delivery.

6. DELIVERY

We deliver free normally by our own vehicles within 25 miles of any of our manufacturing depots. Delivery to any place more than 25 miles from one of our manufacturing depots is subject to our quoted delivery charges. We reserve the right to make delivery of goods contained in one order by more than one consignment and at different times. Where a period is agreed for delivery and such period is not extended by our Agreement, the Purchaser shall take delivery within that period. If the Purchaser fails to take delivery, we shall be entitled at the Purchaser's risk and expense to store the goods at the Purchaser's premises or elsewhere and to demand payment as if they had been despatched. Offloading at point of delivery shall be the responsibility of and be undertaken by the Purchaser.

7. SHORTAGES OR DAMAGE

Goods must be inspected before signature of delivery note and any damage, shortage or discrepancy noted on the delivery note and the goods returned on the same vehicle. The buyer must also give us immediate written notice of the damage, shortage or discrepancy so that we may prompt investigation.

8. RETURN OF GOODS

Goods may not be returned to the Company except by prior written permission of an authorised officer of the Company and such return shall be subject to payment by the Purchaser of handling and re-stocking charges, transport and all other costs incurred by the Company.

9. COMPANY LIABILITY

All our goods are made of the best materials from reputable manufacturers and where stated are manufactured to the appropriate British Standard. Complaints must be given to us immediately, before any action is taken, as responsibility cannot be accepted if repairs or renewals are attempted

Where we agree to rectify any defect, we reserve the right to undertake the work on our own premises. Provided that our product has been installed in accordance with any instructions for installation and any relevant codes of practice and in accordance with the bye-laws and requirements obtaining in any particular area we give the following warranties:

(1) Domestic and Commercial Open Vented Cylinders and Tanks.

If the copper cylinder or tank or any integral pipework proves to be defective either in materials or workmanship, we will either repair or supply replacement at our option with the closest substitute in the case of any obsolete product to any address in Great Britain.

- (a) free of all charge during the first year after delivery by us.
- (b) thereafter at a charge of one-tenth of the then current list price and any copper price supplement and delivery charge during the second year after delivery by us and increasing by a further one-tenth on the second and subsequent anniversary of delivery by us.

AND FURTHER we will meet the contractors/installers reasonable costs in removing and replacing any defective Open Vented Copper Cylinder or Tank with defective integral pipework as follows:

- (i) in the case of vessels of less than 80 imperial gallons capacity up to a maximum of one-half of the extent of our liability in regard to the replacement product expressed in (1) (a) and (b) above
- ii) in the case of vessels larger than 79 imperial gallons capacity up to a maximum of one-quarter of the extent of our liability in regard to the replacement product as expressed in paragraphs (1) (a) and (b) above.

(2) Domestic Mains Fed Products

If the copper storage vessel itself or any integral pipework as part of the storage vessel assembly proves to be defective either in materials or workmanship, we reserve the right to either repair or supply replacements or the closest possible substitute in the case of any obsolete product and will collect and deliver to any address in England, Wales and Scotland (excluding all Scottish Islands).

- (a) free of all charge during the first year after delivery by us.
- (b) thereafter at a charge of one-fifth of the then current list price or any copper price supplement and delivery charge during the second year after delivery by us increasing by a further one-fifth on the second and subsequent anniversary of delivery by us.

AND FURTHER we will meet the contractors/installers reasonable costs in removing and replacing any defective copper storage vessel or storage vessel with defective integral pipework from the Domestic Mains Pressure Range of products up to a maximum of one-third of the extent of our liability in regard to the replacement product expressed in (2) (a) and (b) above.

(3) Components of our products other than Storage Vessels and Integral Pipework. We will either extend to the purchaser the same terms of warranty as we are given by the manufacturer of the component or if the manufacturer does not give any warranty, replace free of charge any component which becomes defective within twelve months after the date of the delivery by us and is returned to us at the purchaser's expense but we shall not meet the cost of removal or shipping or return of the component or any other cost charges or damages incurred by the purchaser.

(4) In the case of the Gulfstream range of products any heat generator found to be defective and admitted to be such by us either as regards materials or workmanship within 12 months from date of installation or 18 months from date of manufacture whichever is the sooner, will be repaired or replaced at our option. **AND FURTHER** we will meet the contractors/installers reasonable costs in removing and replacing any defective heat generator up to a maximum of one-third of the extent of our liability in regard to the replacement product.

(5) In the case of goods manufactured solely in accordance with our specification and designs and in respect of any installation work carried out by or on our behalf, our entire liability and the purchaser's sole remedies (subject to (1-4) above) and shall be as follows:

- (a) we accept liability for death or personal injury to the extent that it results from our negligence that of our employees agents or subcontractors.
- (b) subject to paragraph (d) below, we accept liability for direct physical damage to tangible property to the extent that such damage is caused by our negligence that of our employees agents or subcontractors.
- (c) our total liability to the purchaser over and above any liability to replace under

(1 - 4) above (whether in contract or in tort including negligence) in respect of any one cause of loss or damage claimed to result from any breach of our obligations hereunder, shall be limited to actual money damages which shall not exceed £20,000 provided that such monetary limit shall not apply to any liability on the part of ourselves referred to in paragraph (a) above.

(d) except as provided in paragraph (a) above but otherwise notwithstanding any provision herein contained in no event shall we be liable for the following loss

or damage howsoever caused and even if foreseeable by us or in our contemplation :-

(i) economic loss which shall include loss of profits, business revenue, goodwill or anticipated savings.

(ii) damages in respect of special indirect or consequential loss or damage (other than death, personal injury and damage to tangible property).

(iii) any claim made against the purchaser by any other party (save as expressly provided in paragraph (b) above).

(e) except in respect of our liability referred to in paragraph (a) above no claim may be made or action brought (whether in contract or in tort including negligence) by the purchaser in respect of any goods supplied by us more than one year after the date of the invoice for the relevant goods.

(f) nothing in these Conditions shall confer on the purchaser any rights or remedies to which the purchaser would not otherwise be legally entitled.

(6) Notwithstanding any other provision contained herein the Purchaser's hereby agree to fully indemnify us against any damages losses costs claims or expenses incurred by us in respect of any claim brought against us by any third party for :-

(a) any loss injury or damage wholly or partly caused by any goods supplied by us or their use.

(b) any loss injury or damage wholly or partly caused by the defective installation or sub-standard workmanship or materials used in the installation of any goods supplied by us.

(c) any loss injury or damage in any way connected with the performance of this contract.

PROVIDED that this paragraph (6) will not require the Purchaser to indemnify us against any liability for our own acts of negligence or those of our employees agents or sub-contractors.

FURTHER in the case of goods supplied by us which are re-sold to and installed by a third party by the Purchaser it will be the sole responsibility of the Purchaser to test the goods immediately after their installation to ensure that inter alia they are correctly installed and are in proper working order, and are not likely to cause any loss injury or damage to any person or property.

10. VARIATION OF WARRANTY AND EXCLUSION

Should our warranty and exclusion be unacceptable we are prepared to negotiate for variation in their terms but only on the basis of an increase in the price to allow for any additional liability or risk which may result from the variation.

Purchasers are advised to insure against any risk or liability which they may incur and which is not covered by our warranty.

11. RISK AND RETENTION OF TITLE

(a) goods supplied by us shall be at the Purchaser's risk immediately upon delivery to the Purchaser or into custody on the Purchaser's behalf or to the Purchaser's Order. The Purchaser shall effect adequate insurance of the goods against all risks to the full invoice value of the goods, such insurance to be effective from the time of delivery until property in the goods shall pass to the Purchaser as hereinafter provided.

(b) property in the goods supplied hereunder will pass to the Purchaser when full payment has been made by the Purchaser to us for :-

(i) the goods of the subject of this contract.

(ii) all other goods the subject to of any other contract between the Purchaser and us which, at the time of payment of the full price of the goods sold under this contract, have been delivered to the Purchaser but not paid for in full.

(c) until property in the goods supplied hereunder passes to the Purchaser in accordance with paragraph (2) above.

(i) the Purchaser shall hold the goods in a fiduciary capacity for us and shall store the same separately from any other goods in the Purchaser's possession and in a manner which enables them to be identified as our goods.

(ii) the Purchaser shall immediately return the goods to us should our authorised representative so request. All the necessary incidents associated with a fiduciary relationship shall apply.

(d) the Purchaser's right to possess the goods shall cease forthwith upon the happening of any of the following events, namely :-

(i) if the Purchaser fails to make payment in full for the goods within the time stipulated in clause 4 hereof.

(ii) if the Purchaser, not being a company, commits any act of bankruptcy, makes a proposal to his or her creditors for a compromise or does anything which would entitle a petition for a Bankruptcy Order to be presented.

(iii) if the Purchaser, being a company, does anything or fails to do anything which would entitle an administrator or an administrative receiver or a receiver to take possession of any assets or which would entitle any person to present a petition for winding up or to apply for an administration order.

(e) the Purchaser hereby grants to us an irrevocable licence to enter at any time any vehicle or premises owned or occupied by the Purchaser or in the possession of the Purchaser for the purposes of repossessing and recovering any such goods the property in which has remained in us under paragraph (2) above. We shall not be responsible for and the Purchaser will indemnify

(f) notwithstanding paragraph (3) hereof and subject to paragraph (7) hereof, the Purchaser shall be permitted to sell the goods to third parties in the normal course of business. In this respect the Purchaser shall act in the capacity of our commission agent and the proceeds of such sale :-

(i) shall be held in trust for us in a manner which enables such proceeds to be identified as such, and :

(ii) shall not be mixed with other monies nor paid into an overdrawn bank account.

We, as principal, shall remunerate the Purchaser as commission agent a commission depending upon the surplus which the Purchaser can obtain over and above the sum, stipulated in this contract of supply which will satisfy us.

(g) in the event that the Purchaser shall sell any of the goods pursuant to clause (6) hereof, the Purchaser shall forthwith inform us in writing of such sale and of the identity and address of the third party to whom the goods have been sold.

(h) if, before property in the goods passes to the Purchaser under paragraph (2) above the goods are or become affixed to any land or building owned by the Purchaser it is hereby agreed and declared that such affixation shall not have the effect of passing property in the goods to the Purchaser.

~~Further, should the goods property in the goods shall pass without the Purchaser's~~
in ~~paragraph (2) above~~ if the goods are or become affixed to any land ~~(ii) building~~ (and the Purchaser does not own the land or building) the landlord of such land or building.

(iii) forthwith inform us in writing of such affixation and of the address of the land or building concerned.

The Purchaser warrants to repair and make good any damage caused by the affixation of the goods to or their removal from any land or building and to indemnify us against all loss damage or liability we may incur or sustain as a result of affixation or removal.

(i) in the event that, before property in the goods has passed to the Purchaser under paragraph (2) hereof, the goods or any of them are lost, stolen, damaged or

destroyed :-

(i) the Purchaser shall forthwith inform us in writing of the fact and circumstances of such loss, theft, damage or destruction.

(ii) the Purchaser shall assign to us the benefit of any insurance claim in respect of the goods so lost, stolen, damaged or destroyed.

12. NON-PAYMENT

If the Purchaser shall fail to make full payment for the goods supplied hereunder within the time stipulated in clause 4 hereof or be in default of payment for any other reason then, without prejudice to any of our other rights hereunder, we shall be entitled to stop all deliveries of goods and materials to the Purchaser, including deliveries or further deliveries of goods under this contract. In addition we shall be entitled to terminate all outstanding orders.

13. RISK

All goods sold by us shall be at the sole risk of the Purchaser from the date of despatch by us of the invoice for their price.

14. VALUE ADDED TAX

All prices quoted are exclusive of Value Added Tax which will be charged at the rate ruling at the date of despatch of invoice.

15. TRADE SALES ONLY

We are only prepared to deal with those who are not consumers within the terms of the Unfair Contract Terms Act 1977, the Sale of Goods Act 1979 and the Supply of Goods and Services Act 1982. Accordingly any person who purchases from us shall be deemed to have represented that he is not a consumer by so purchasing.

16. JURISDICTION

The Agreement is subject solely to English Law and any dispute arising hereunder shall be settled in accordance therewith.

PULSACOIL III MANUAL ISSUE 5: 08/00

1. **Page 6** - New Paragraph in Hot and Cold Water Services under item F.

'On the odd occasion it is felt necessary to provide a secondary circulation. We would recommend the use of Raychem HWAT Plus or similar self regulating trace heating to maintain the temperature in the hot water distribution system. The system must be installed and commissioned fully in accordance with the manufacturers instructions.'