

A-CLASS *PulsaCoil*

A mains pressure hot water supply system incorporating an off peak electric thermal store

Design, Installation & Servicing Instructions

Model Numbers

PulsaCoil 145
PulsaCoil 185
PulsaCoil 215
PulsaCoil 235

All models comply with the water heater manufacturers specification for thermal stores

 **Gledhill**
The appliance of innovation

ISSUE 9: 06-08

Section	Page
DESIGN	
Introduction	3
Technical Data	5
System Details	9
INSTALLATION	
Site Requirements	13
Installation	14
Commissioning	19
SERVICING	
Annual Service	20
Changing Components	20
Short Parts List	21
Fault Finding	22
ADDENDIX	
Addendix A	25
Addendix B	26
Addendix C	28
Addendix D	29
Terms & Conditions	30



*The code of practice for the installation,
commissioning & servicing of central heating systems*

Building Regulations and Benchmark Commissioning

The Building Regulations (England & Wales) require that the installation of a heating appliance be notified to the relevant Local Authority Building Control Department. From 1st April 2005 this can be achieved via a Competent Person Self Certification Scheme as an option to notifying the Local Authority directly. Similar arrangements will follow for Scotland and will apply in Northern Ireland from 1st January 06.

CORGI operates a Self Certification Scheme for gas heating appliances.

These arrangements represent a change from the situation whereby compliance with the Building Regulations was accepted if the Benchmark Logbook was completed and this was then left on site with the customer).

With the introduction of a self certification scheme, the Benchmark Logbook is being replaced by a similar document in the form of a commissioning check list and a service interval record is included with all gas appliance manuals. However, the relevant Benchmark Logbook is still being included with all Thermal Storage products and unvented cylinders.

Gledhill fully supports the Benchmark aims to improve the standards of installation and commissioning of central heating systems in the UK and to encourage the regular servicing of all central heating systems to ensure safety and efficiency.

Building Regulations require that the heating installation should comply with the manufacturer's instructions. It is therefore important that the commissioning check list is completed by the competent installer. This check list only applies to installations in dwellings or some related structures.

The Gledhill PulsaCoil range is a WBS listed product and complies with the WMA Specification for hot water only thermal storage products. The principle was developed originally in conjunction with British Gas. This product is manufactured under an ISO 9001:2000 Quality System audited by BSI.

The Gledhill Group's first priority is to give a high quality service to our customers.

Quality is built into every Gledhill product and we hope you get satisfactory service from Gledhill.

If not please let us know.

Any water distribution system/installation must comply with the relevant recommendations of the current version of the Regulations and British Standards listed below:-

Building Regulations
Requirements for Electrical Installations
Water Regulations
Manual Handling Operations Regulations

British Standards
BS6700 and BS7671.

A suitably competent trades person must install the PulsaCoil and carry out any subsequent maintenance/repairs. In fact the appliance front cover is secured by 2 screws and this should only be removed by a competent trades person. The manufacturer's notes must not be taken as overriding statutory obligations.

The PulsaCoil A-Class is not covered by section G3 of the current Building Regulations and is therefore not notifiable to Building Control.

The PulsaCoil A-Class is not intended for use by persons (including children) with reduced physical, sensory or mental capabilities, or lack of experience or knowledge, unless they have been given supervision or instruction concerning use of the appliance by a person responsible for their safety.

Children should be supervised to ensure that they do not play with the appliance.

The information in this manual is provided to assist generally in the selection of equipment. The responsibility for the selection and specification of the equipment must however remain that of the customer and any Designers or Consultants concerned with the design and installation.

Please Note: We do not therefore accept any responsibility for matters of design, selection or specification or for the effectiveness of an installation containing one of our products unless we have been specifically requested to do so.

All goods are sold subject to our Conditions of Sale, which are set out at the rear of this manual.

In the interest of continuously improving the PulsaCoil range, Gledhill Water Storage Ltd reserve the right to modify the product without notice, and in these circumstances this document, which is accurate at the time of printing, should be disregarded. It will however be updated as soon as possible after the change has occurred.



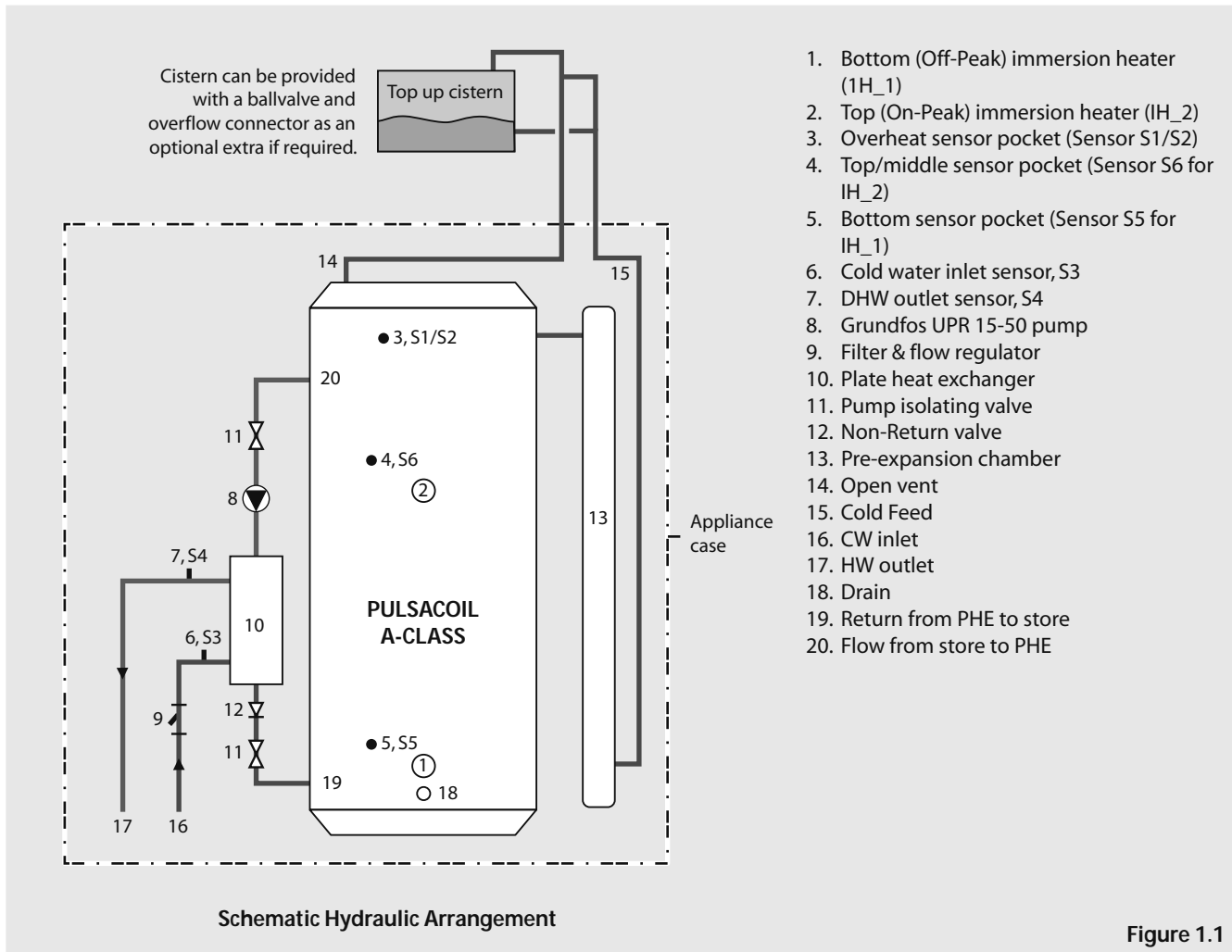

The Pulsacoil A-Class shown schematically above is designed to provide an improved method of supplying mains pressure hot water when used with a suitable off peak electric supply/tariff.

An important feature of the concept is that hot water can be supplied directly from the mains at conventional flow rates without the need for temperature and pressure relief safety valves or expansion vessels. This is achieved by passing the mains water through a plate heat exchanger. The outlet temperature of the domestic hot water is maintained by a printed circuit control board, which controls the speed of the pump circulating the primary water from the store through the plate heat exchanger.

The Building Regulations L1A: New dwellings/L1B: Existing dwellings and the requirements set out in the Domestic Heating Compliance Guide specify that "where the mains water hardness exceeds 200ppm provision should be made to treat the feed water to water heaters and the hot water circuit of combination boilers to reduce the rate of accumulation of lime scale".

To comply with this requirement the hardness of the mains water should be checked by the installer and if necessary the optional factory fitted in-line scale inhibitor should be specified at the time of order for hardness levels between 200 and 300 ppm (mg/l).

Where the water is very hard ie 300ppm (mg/l) and above the optional polyphosphate type, inhibitor should be specified at the time of order. However, this will need to be fitted by the installer at a suitable point in the cold water supply to the appliance.

THE PRINTED CIRCUIT BOARD INCORPORATES THE FACILITY TO AUTOMATICALLY RUN THE D.H.W. PRIMARY PUMP FOR ABOUT 3 SECONDS EVERY 30 HOURS TO HELP PREVENT IT STICKING. FOR THIS REASON WE WOULD RECOMMEND THAT ONCE THE APPLIANCE IS INSTALLED IT SHOULD BE COMMISSIONED AND THE ELECTRICITY LEFT ON TO THE APPLIANCE.

Because this product does not require a safety discharge from a temperature and pressure relief valve, any installations will be easy to incorporate into the building and will not suffer from the problems associated with using PVCu soil stacks to take the discharge from unvented cylinders.

The heat losses from thermal stores should not be directly compared with heat losses from unvented or vented cylinders because they are treated differently in SAP. The SAP calculator takes account of the type of store and various correction factors are included to reflect the different ways that the hot water and heating operates.

Table 1.1

Technical Specification PulsaCoil A-Class				
Model	PCA145	PCA185	PCA215	PCA235
Height (mm)	1042	1142	1300	1440
Width (mm)	530	530	530	550
Depth (mm)	595	595	595	595
Min cupboard height (mm)	1800	1900	2050	2200
Min cupboard width (mm)	550	550	550	570
Min cupboard depth (mm)	600	600	600	600
Weight (empty) (kg)	40	42	44	48
Weight (full) (kg)	187	206	230	258
Volume of water heated by on-peak heater (litres)	65	65	70	75

Table 1.2

Model Selection Guide PulsaCoil A-Class				
Dwelling Type				
Bedroom	1-2	2-3	2-3	2-4
Bathroom	1 or	1	1	2
En-suite shower rooms	1	1	2	1
Standard Economy-7 tariff	PCA145	PCA185	PCA215	PCA235
10hr Heatwise tariff	PCA145	PCA145	PCA185	PCA215

Notes:-

1. Plastic top up cistern will be supplied separately.
2. The flow rates are based on a 35°C temperature rise and assume that recommended pressures and adequate flow are available at the appliance. The actual flow rate from the appliance is automatically regulated to a maximum of 28 litres/min.
3. Unit is supplied on a 100mm high installation base.
4. The domestic hot water outlet temperature is automatically regulated to approximately 52°C at the bath flow rate of 18 litres/min recommended by BS 6700. The temperature is not user adjustable.

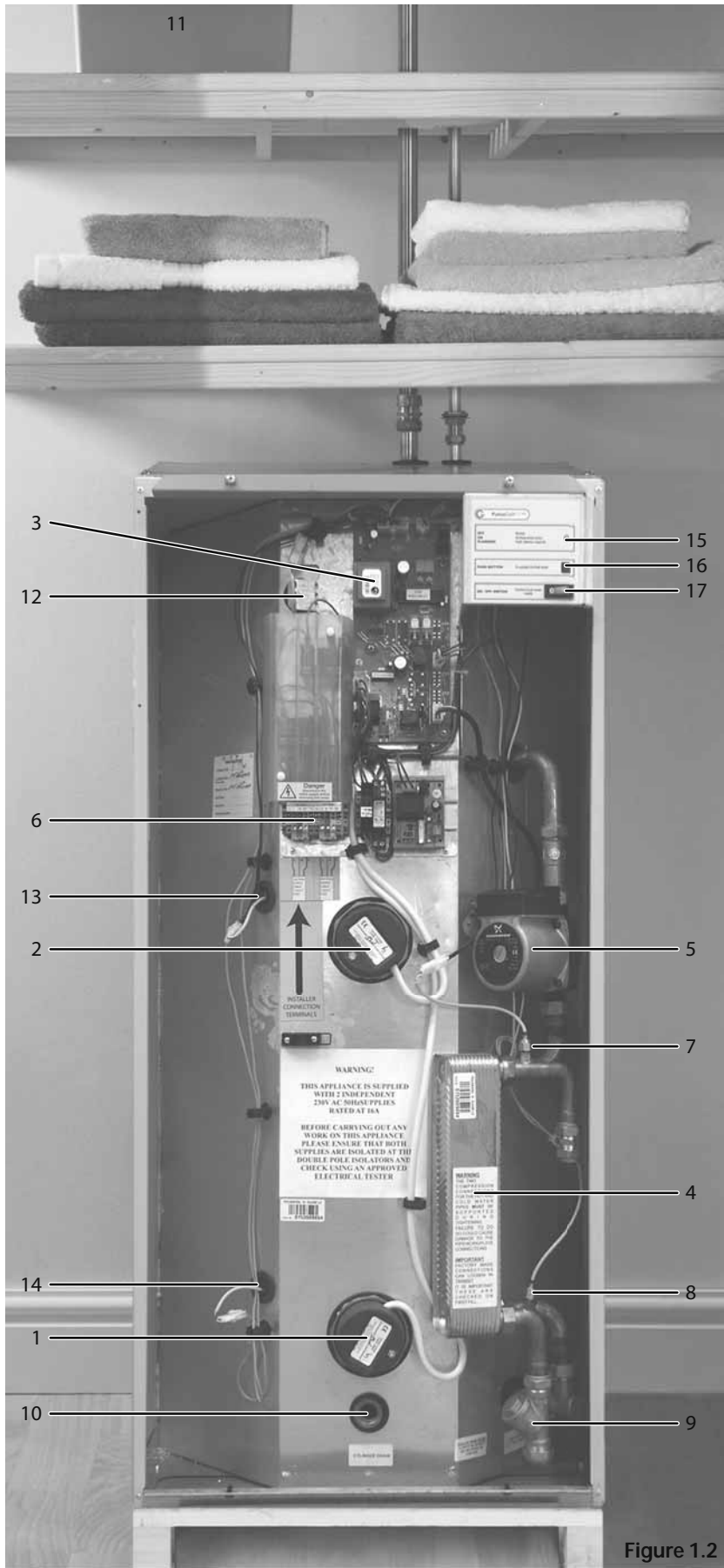

Figure 1.2

Standard Equipment

The standard configuration of the Pulsacoil A-Class is shown opposite. The Printed Circuit Board (A.C.B.), mounted inside the appliance, controls the operation of the complete system. This is pre-wired to a terminal strip where all electrical connections terminate. It is supplied with the following factory fitted equipment:-

1. 3kW Off-Peak immersion heater
2. 3kW On-Peak boost immersion heater
3. Printed Circuit Board
4. Plate heat exchanger
5. Domestic hot water primary (plate heat exchanger) pump
6. Isolating terminal connectors for dry fire protection
7. DHW temperature sensor
8. Incoming cold water sensor
9. Strainer and flow regulator
10. Screwed connection for a drain tap
11. Top up cistern complete with cold feed/open vent pipework assembly is supplied separately
12. Overheat thermostat
13. Middle store control sensor
14. Bottom store control sensor
15. Operation/warning light
16. Boost/reset button
17. On/Off switch

Note : Both immersion heaters are low watts density type with incoloy 825 sheaths and are specially manufactured to suit Thermal Stores. It is recommended that any replacements should be obtained from Gledhill Water Storage.

Optional Extra Equipment

- Scale inhibitor for mains water services with hardness levels above 200 ppm (mg/l)
- Hot and cold water manifolds for use with plastic pipework.
- Ballvalve/overflow connector for top up cistern.

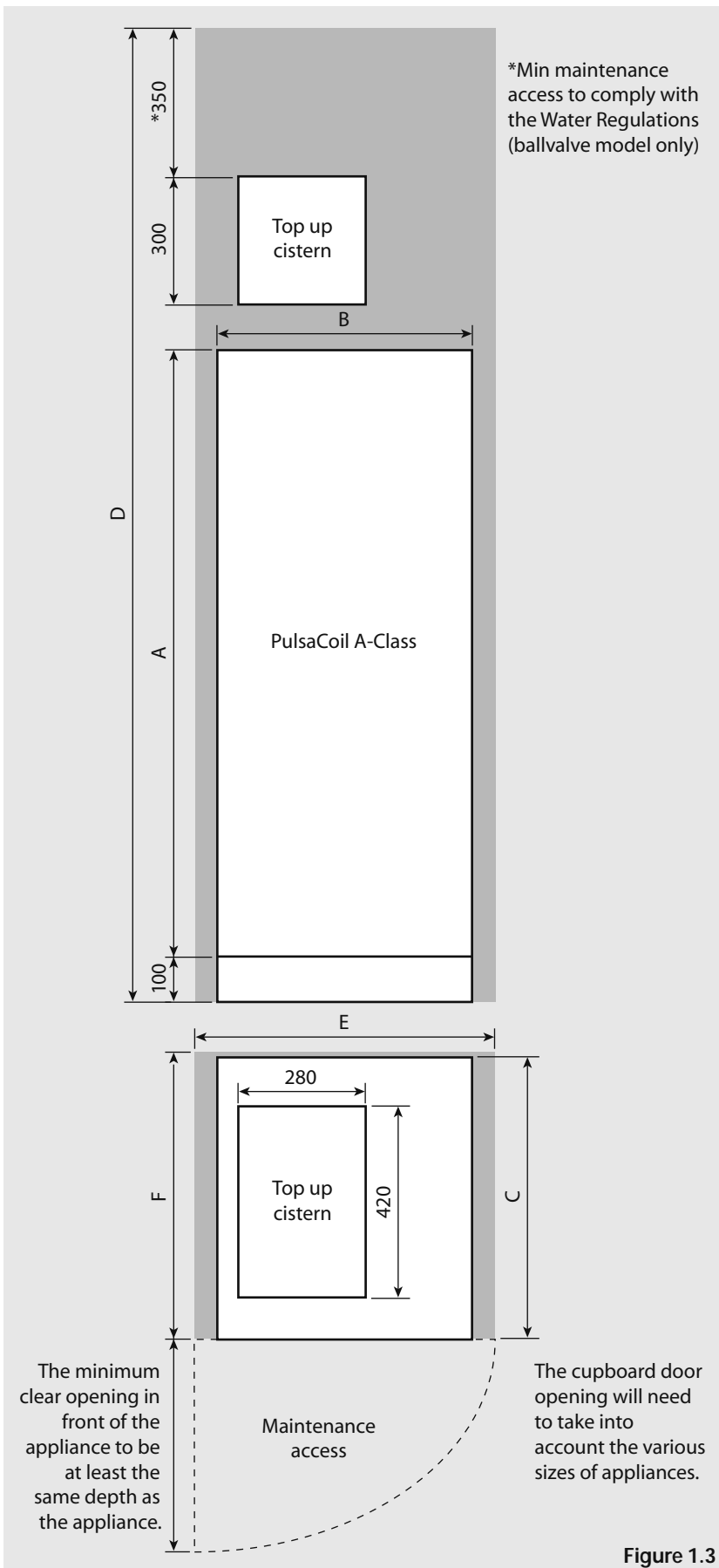

Figure 1.3

Appliance Dimensions			
Model	Height A	Width B	Depth C
PCA145	1042	530	595
PCA185	1142	530	595
PCA215	1300	530	595
PCA235	1440	550	595

Note: The Appliance dimensions above do not allow for the 100mm high installation base.

The following table of minimum cupboard dimensions only allow the minimum space required for the appliance (including the F & E cistern). Any extra space required for shelving etc in the case of airing cupboards etc must be added.

Minimum Cupboard Dimensions			
Model	Height D	Width E	Depth F
PCA145	1800	550	600
PCA185	1900	550	600
PCA215	2050	550	600
PCA235	2200	570	600

Note: The above dimensions are based on the Appliance and the Top up cistern (fitted with a ballvalve) being in the same cupboard. **If the manual fill method is chosen the heights can be reduced by 125mm.**

If pipework needs to rise vertically adjacent to the appliance the width/depth will need increasing to accommodate this.

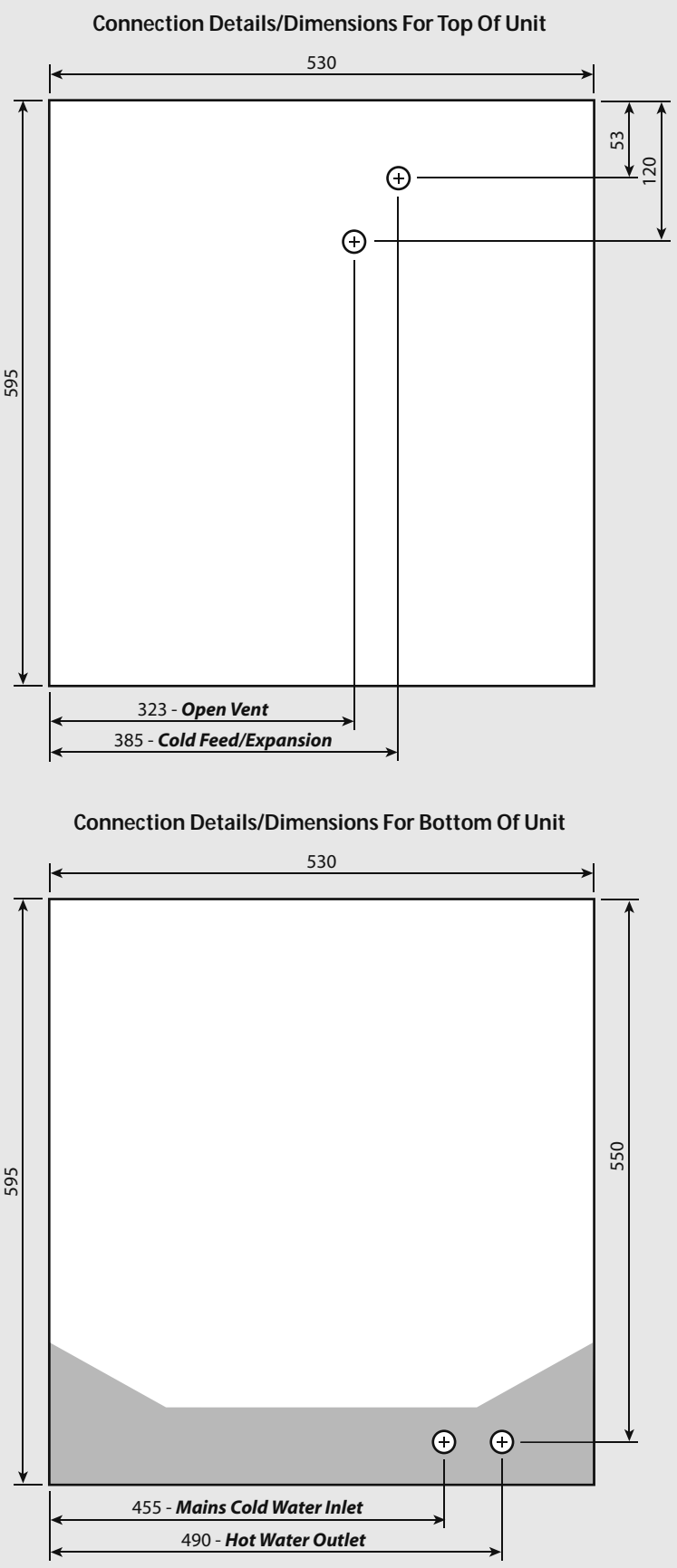

Figure 1.4

Plan Of Appliance Connections

The PulsaCoil A-Class units are supplied on an installation base to allow the pipe runs to connect to the appliance from any direction. It is easier if all pipes protrude vertically in the cut out area shown. Compression or push fit connections can be used. All pipe positions are approximate and subject to a tolerance of +/- 10mm in any direction. Space will also be required for a 15mm cold water supply and a 22mm warning / overflow pipe (if the optional extra ball valve and overflow connector have been specified. If a warning/overflow pipe is NOT provided the F&E Cistern should be filled from a temporary hose connection incorporating a double check valve. This can be from a temporary hose connection supplied from a cold water tap or a permanent cold branch provided adjacent to the Top up Cistern. The temporary connection must be removed once the appliance is filled.

Note: All dimensions are shown in mm and are to the centre line of the pipework.

Hot and Cold Water System

General

A schematic layout of the hot and cold water services in a typical small dwelling is shown below. PulsaCoil A-Class will operate at mains pressures as low as 1 bar and as high as 5 bar although the recommended range is 2-3 bar dynamic at the appliance. If the manifolds (available as an optional extra) are being used the inlet pressure to the manifold must be a minimum of 2 bar. It is also important to check that all other equipment and components in the hot and cold water system are capable of accepting the mains pressure available to the property. If the mains pressure can rise above 5 bar or the maximum working pressure of any item of equipment or component to be fitted in the system, a pressure limiting (reducing) valve set to 3 bar will be required.

If you encounter a situation where the water pressure is adequate but flow rates are poor please contact our technical helpline for details of an effective solution.

Note : Each Pulsacoil A-Class is fitted with a strainer and flow regulator on the cold mains supply connection. If the supply pressure is less than 2 bar or if the manifolds (available as an optional extra) are being used or if all taps are provided with flow regulators the flow regulator on the cold inlet should be removed.

No check valve or similar device should be fitted on the cold water supply branch to the PulsaCoil A-Class.

The Building Regulations L1A: New dwellings/L1B: Existing dwellings and the requirements set out in the Domestic Heating Compliance Guide specify that "where the mains water hardness exceeds 200ppm provision should be made to treat the feed water to water heaters and the hot water circuit of combination boilers to reduce the rate of accumulation of lime scale".

To comply with this requirement the hardness of the mains water should be checked by the installer and if necessary the optional factory fitted in-line scale inhibitor should be specified at the time of order for hardness levels between 200 and 300 ppm (mg/l).

Where the water is very hard ie 300ppm (mg/l) and above the optional polyphosphate type inhibitor should be specified at the time of order. However, this will need to be fitted by the installer at a suitable point in the cold water supply to the appliance.

The hot water flow rate from the PulsaCoil A-Class is directly related to the adequacy of the cold water supply to the dwelling. This must be capable of providing for those services, which could be required to be supplied simultaneously, and this maximum demand should be calculated using procedures defined in BS 6700.

If a water meter is fitted in the service pipe, it should have a nominal rating to match the maximum hot and cold water peak demands calculated in accordance with BS 6700. This could be up to 60ltr/min in some properties.

Note: The diagram below shows the top up cistern with ballvalve and warning/overflow pipe which can be supplied as an optional extra if required. However, the standard preferred arrangement is for the cistern to be manually filled from a temporary hose connection fitted with a double check valve.

The cistern must not be fitted more than 10 metres above the PulsaCoil A-Class appliance itself.

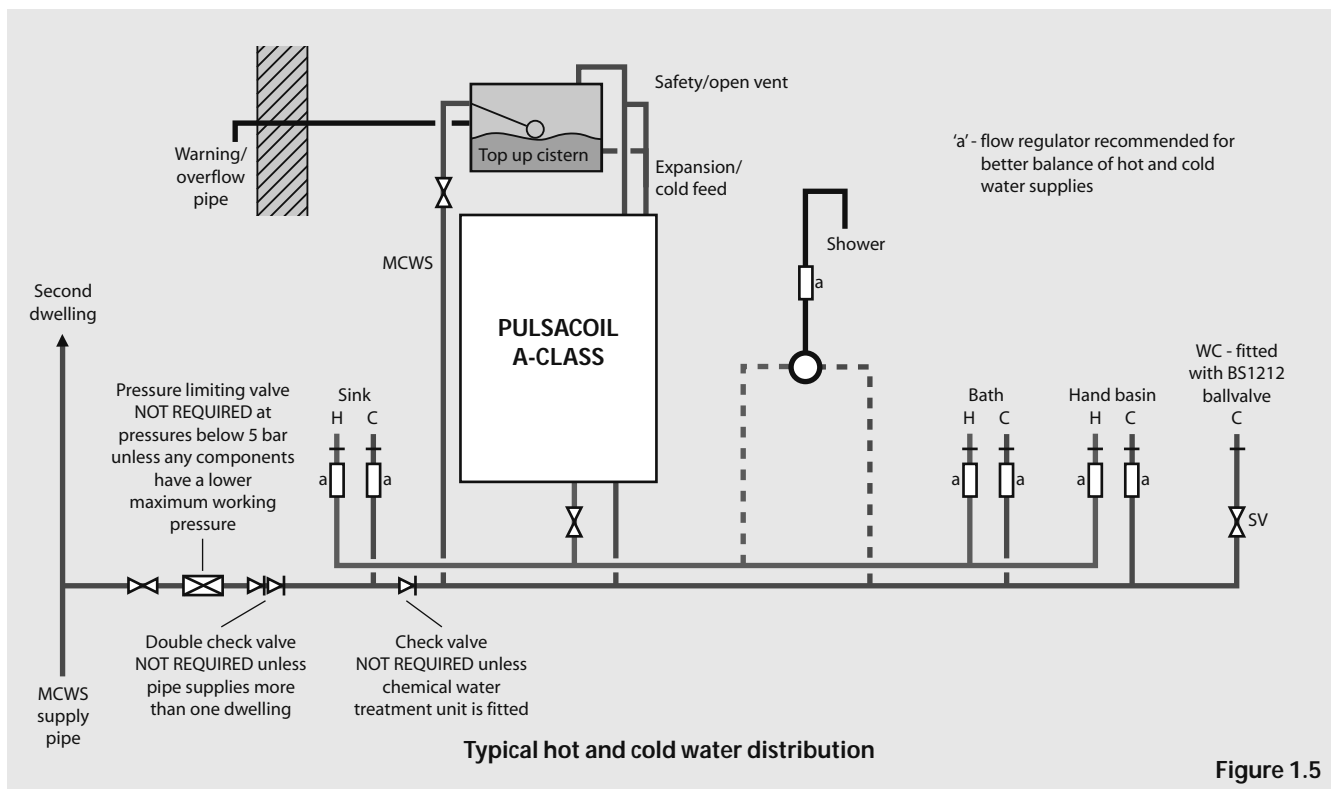

Hot and Cold Water System

Pipe Sizing / Materials

To achieve even distribution of the available supply of hot and cold water, it is important in any mains pressure system, that the piping in a dwelling should be sized in accordance with BS 6700. This is particularly important in a large property with more than one bathroom.

However, the following rule of thumb guide lines should be adequate for most smaller property types as long as water pressures are within the recommended range.

1. A 15mm copper or equivalent external service may be sufficient for a small 1 bathroom dwelling (depending upon the flow rate available), but the minimum recommended size for new dwellings is 22mm (25mm MDPE).
2. The internal cold feed from the main incoming stop tap to the PulsaCoil A-Class should be run in 22mm pipe. The cold main and hot draw-off should also be run in 22mm as far as the branch to the bath tap.
3. The final branches to the hand basins and sinks should be in 10mm and to the baths and showers in 15mm (1 metre minimum).
4. **We would recommend that best results for a balanced system are achieved by fitting appropriate flow regulators to each hot and cold outlet. This is particularly relevant where the water pressures are above the recommended water pressure range. Details of suitable flow regulators are provided in Appendix A.**

Note: If manifolds (available as an optional extra) are being used suitable flow regulators are automatically provided in the manifold and do not need to be provided at each outlet. See Appendix B for further details.

All the recommendations with regard to pipework systems in this manual are generally based on the use of BS/EN Standard copper pipework and fittings.

However, we are happy that plastic pipework systems can be used in place of copper internally as long as the chosen system is recommended for use on domestic hot and cold water systems by the manufacturer and is installed fully in accordance with their recommendations.

This is particularly important in relation to use of push fit connections when using the optional flexible hose kits - see installation section of this manual.

It is also essential that if an alternative pipework material/system is chosen the manufacturer confirms that the design criteria of the new system is at least equivalent to the use of BS/EN Standard copper pipework and fittings.

Taps/Shower Fittings

Aerated taps are recommended to prevent splashing.

Any type of shower mixing valve can be used as long as both the hot and cold supplies are mains fed. However all mains pressure systems are subject to dynamic changes particularly when other hot and cold taps/showers are opened and closed, which will cause changes in the water temperature at mixed water outlets such as showers. For this reason and because these are now no more expensive than a manual shower we strongly recommend the use of thermostatic showers with this appliance.

The shower head provided must also be suitable for mains pressure supplies.

However, if it is proposed to use a 'whole body' or similar shower with a number of high flow/pressure outlets please discuss with the Gledhill technical department.

The hot water supply to a shower-mixing valve should be fed wherever practical directly from the PulsaCoil A-CLASS or be the first draw-off point on the hot circuit. The cold supply to a shower-mixing valve should wherever practical be fed directly from the rising mains via an independent branch. The shower must incorporate or be fitted with the necessary check valves to provide back-syphonage protection in accordance with the Water Regulations.

The supply of hot and cold mains water directly to a bidet is permitted provided that it is of the over-rim flushing type and that a type 'A' air gap is incorporated.

Hot and Cold Water System

If the length of the hot water draw off pipework is excessive and the delivery time will be more than 60 seconds before hot water is available at the tap, you may wish to consider using trace heating to the hot water pipework such as the Raychem HWAT system. Please consult Gledhill Technical Department for further details.

Note: A conventional pumped secondary circulation system is **NOT** suitable for use with this appliance.

It is important that the cold water pipework is adequately separated/protected from any heating/hot water pipework to ensure that the water remains cold and of drinking water quality.

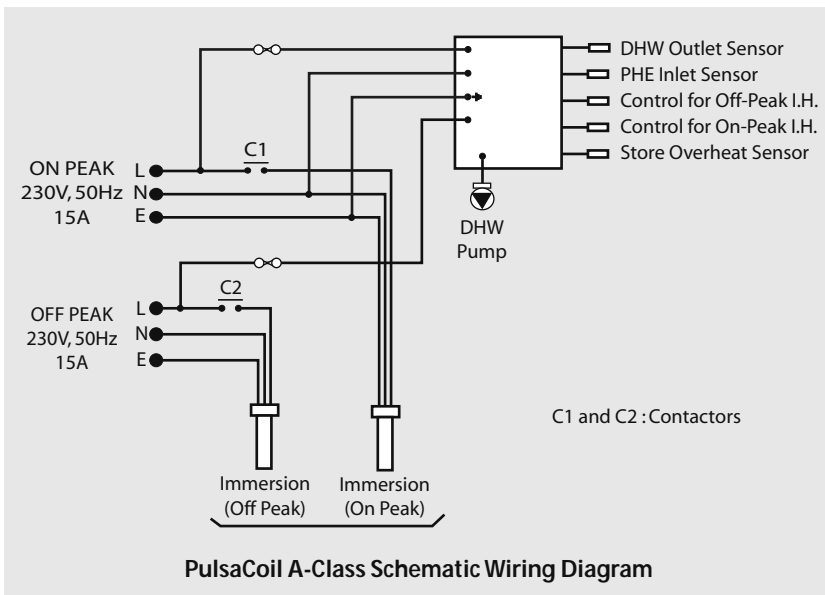

Electrical Installation

The Schematic arrangement of the wiring within the PulsaCoil A-Class is shown above.

The whole of the electrical installation shall be designed and installed by a competent person fully in accordance with the latest edition of the Requirements for Electrical installations BS 7671.

The PulsaCoil A-Class appliance is provided with two side entry 3kW immersion heaters and has been designed to generally operate with an off peak supply.

The lower immersion heater heats the whole of the contents and is normally connected to the off peak supply.

The upper immersion heater is positioned at a level on the PulsaCoil A-Class to heat the top 65 - 75 litres of the store - see Technical Data Table on page 5. This is connected to the unrestricted on peak supply and is switched manually by the householder using the button provided on the front of the appliance. When pressed the on-peak boost will remain active until the next time the off-peak becomes available (unless switched off again manually).

The size of the appliance and the need to use the on peak boost facility is reduced if a better off peak tariff can be agreed with the electrical supply company - see Model Selection Guide on page 5.

Wiring The PulsaCoil With A Split Consumer Unit I.e. Separate On And Off Peak Supplies.

Historically this has been the typical supply method and no special wiring arrangements are required.

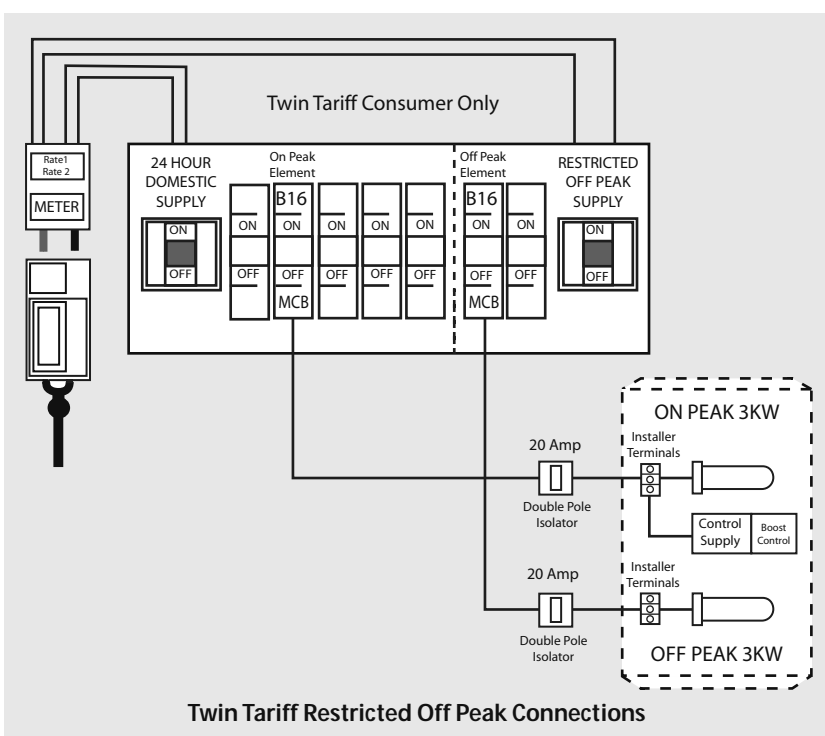

The appliance is designed to be installed in an airing/cylinder cupboard and the relevant minimum dimensions are provided in the Technical Data section of this manual.

Because of the ease of installation we recommend that the cupboard construction is completed and painted before installation of the appliance. The cupboard door can be fitted after installation.

If the unit needs to be stored prior to installation it should be stored upright in a dry environment and on a level base/floor.

Installation and maintenance access is needed to the front of the appliance and above the Top up cistern. See the Technical Data section of this manual for further details.

The minimum dimensions contained in the Technical Data section of this manual allow for the passage/connection of pipes to the appliance from any direction as long as the appliance is installed on the installation base provided. If the installation base is not used extra space may be needed to allow connection to the pipework and the whole of the base area should be continuously supported on a material which will not easily deteriorate if exposed to moisture.

The floor of the cupboard needs to be level and even and capable of supporting the weight of the appliance when full. Details of the weight when full is provided in the Technical Data section of this manual.

The appliance is designed to operate as quietly as practicable. However, some noise (from pumps etc) is inevitable when hot water is being used. This will be most noticeable if the cupboards are located adjacent to bedrooms, on bulkheads, or at the mid span of a suspended floor. Some noise may also be experienced from the immersion heaters as the store approaches its design temperature.

Cupboard temperatures will normally be slightly higher than in a conventional system and the design of the cupboard and door will need to take this into account. No ventilation is normally required to the cupboard.

The separate Top up cistern will need to be located on top of the appliance or at high level in the cupboard housing the PulsaCoil A-Class. The dimensions and clearances are provided in the Technical Data section of this manual. The location will need to provide a suitable route for the cold feed expansion pipe as well as the open safety vent pipe. The location will also need to provide a suitable route and discharge position for the warning/overflow pipe and the ballvalve supply from the mains cold water system (if provided) if these have been ordered as an optional extra.

Note: The standard appliance is supplied with a cistern without a ballvalve/overflow for filling manually.

An electrical supply must be available which is correctly earthed, polarized and in accordance with the latest edition of the IEE requirements for electrical Installations BS 7671.

The electrical mains supply needs to be 230V/50Hz.

The sizes/types of electrical supplies must be as detailed in System Details section of this manual. A means for disconnection from the supply mains having a contact separation in all poles that provides full disconnection under over voltage category III conditions must be incorporated in the fixed wiring in accordance with the wiring rules. This shall be located within 1m of the appliance and only serve the appliance.

The hot and cold water 'first fix' pipework should be terminated 50mm above the finished floor level in accordance with the dimensions provided in the Technical Data section of this manual.

INSTALLATION

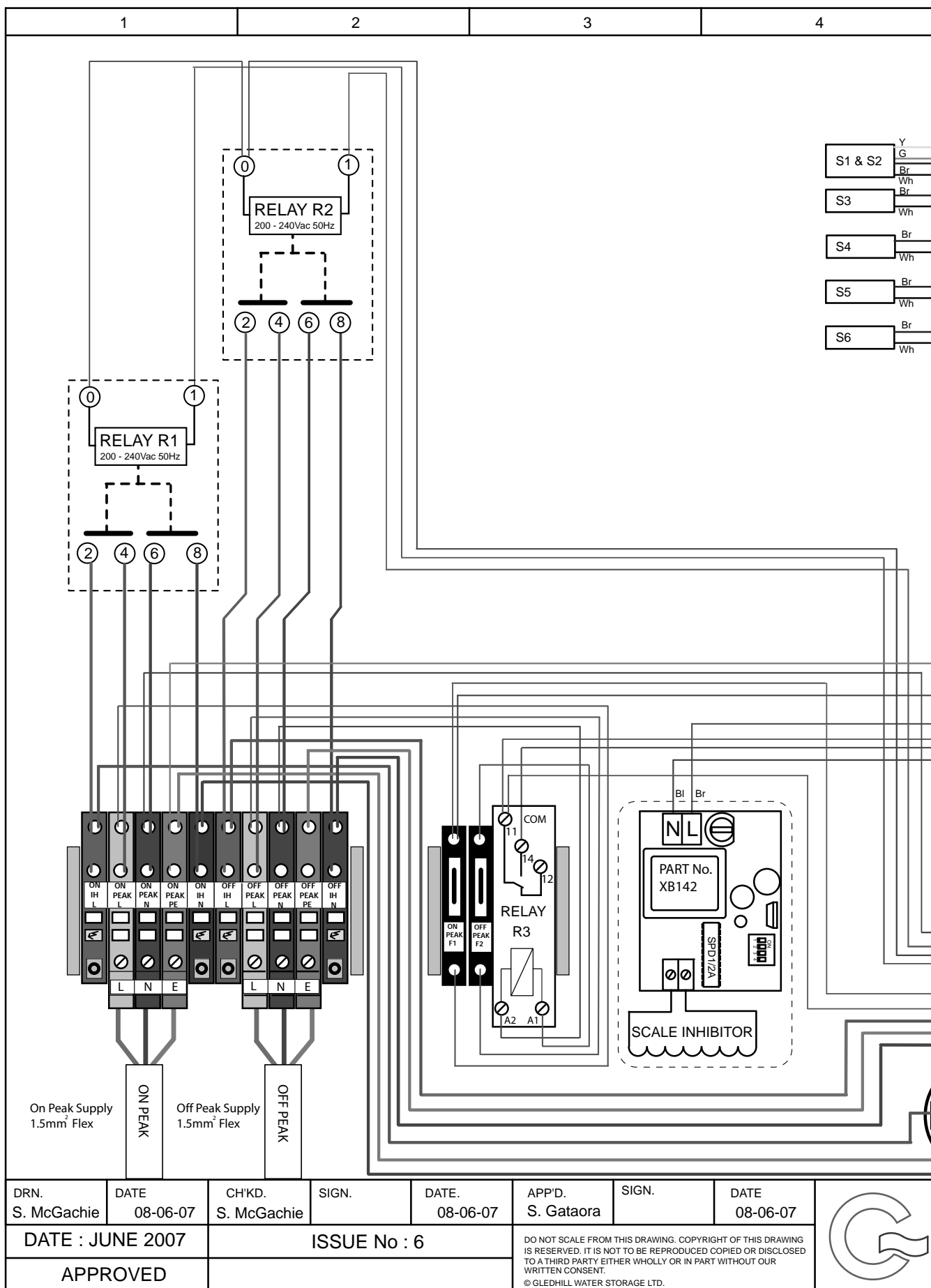

INSTALLATION

DRN. S. McGachie	DATE 08-06-07	CHKD. S. McGachie	SIGN.	DATE. 08-06-07	APP'D. S. Gataora	SIGN.	DATE 08-06-07
DATE : JUNE 2007		ISSUE No : 6			DO NOT SCALE FROM THIS DRAWING. COPYRIGHT OF THIS DRAWING IS RESERVED. IT IS NOT TO BE REPRODUCED COPIED OR DISCLOSED TO A THIRD PARTY EITHER WHOLLY OR IN PART WITHOUT OUR WRITTEN CONSENT. © GLEDHILL WATER STORAGE LTD.		
APPROVED							



INSTALLATION

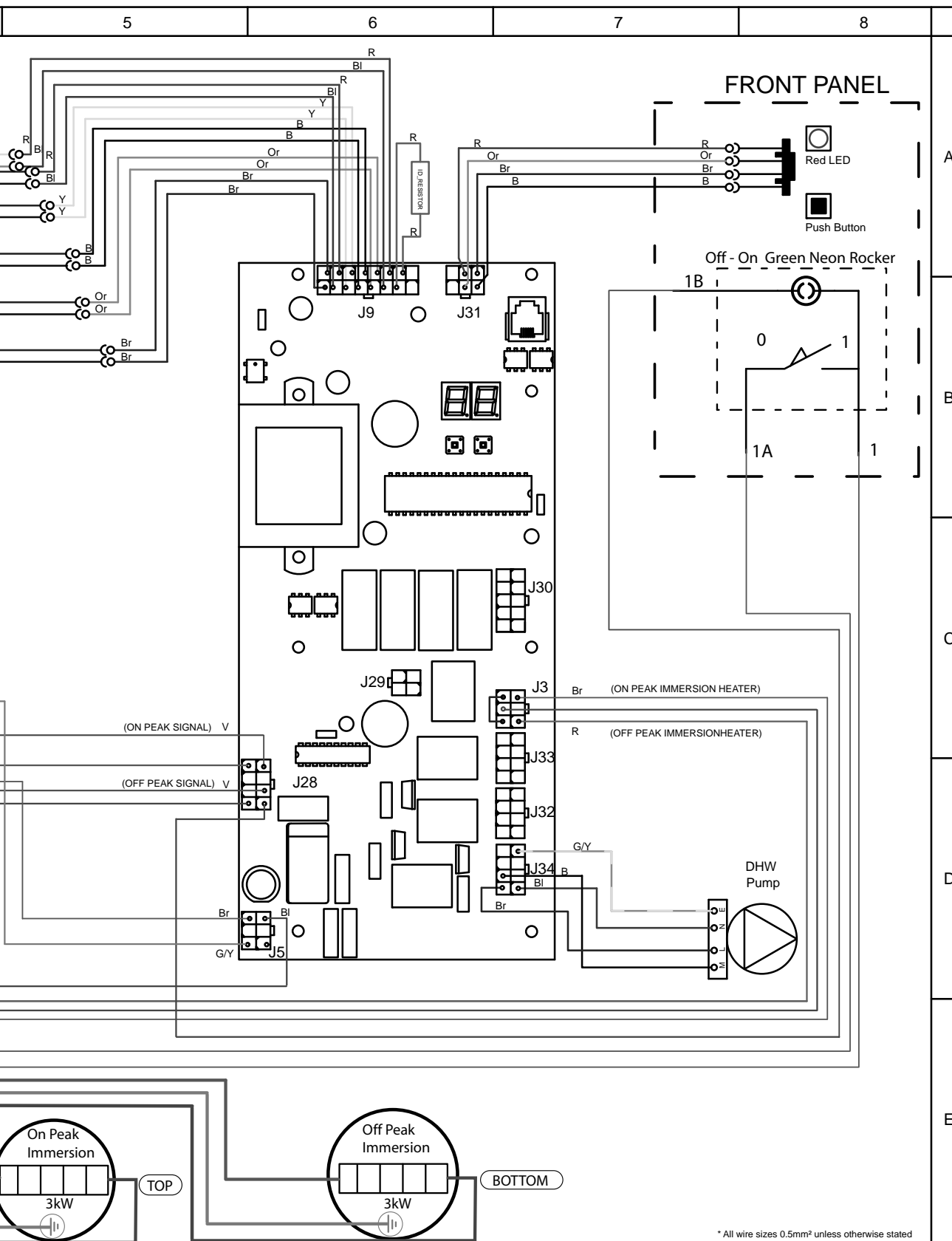

* All wire sizes 0.5mm² unless otherwise stated

GLEDHILL WATER STORAGE LTD.
 SYCAMORE TRADING ESTATE
 SQUIRES GATE LANE
 BLACKPOOL
 LANCASHIRE
 FY4 3RL

TITLE
 'A' CLASS PULSACOIL APPLIANCE
 ELECTRICAL SCHEMATIC DRAWING

JOB NAME
 'A' CLASS PULSACOIL APPLIANCE

DRG. SIZE
 A3

DRG. NAME
 'A' Class Pulsacoil ver 6.ai

INSTALLATION

INSTALLATION

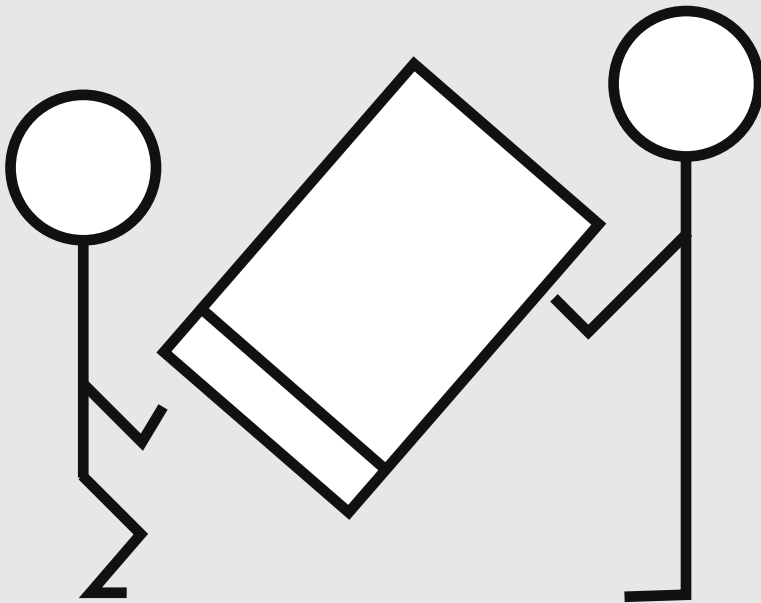

HANDLING

When lifting the unit work with someone of similar build and height if possible.

Choose one person to call the signals.

Lift from the hips at the same time, then raise the unit to the desired level.

Move smoothly in unison.

Larger units may require a team lift.

A specific manual handling assessment is shown in Appendix D at the rear of this manual.

Preparation/placing The Appliance In Position.

The 'first fix' pipework positions should be checked using the template provided with each appliance. If these have been followed installation is very simple and much quicker than any other system.

The appliance is supplied shrink wrapped on a timber installation base. Carrying handles are also provided in the back of the casing.

The feed and expansion cistern complete with ballvalve, cold feed/expansion and overflow/warning pipe fittings are provided in a separate box.

The appliance should be handled carefully to avoid damage and the recommended method is shown above.

Note: Although the above guidance is provided any manual handling/lifting operations will need to comply with the requirements of the Manual Handling Operations Regulations issued by the H.S.E.

The appliance can be moved using a sack truck on the rear face although care should be taken and the route should be even.

In apartment buildings containing a number of storeys we would recommend that the appliances are moved vertically in a mechanical lift.

If it is proposed to use a crane expert advice should be obtained regarding the need for slings, lifting beams etc.

Before installation the site requirements should be checked and confirmed as acceptable.

The plastic cover and protective wrapping should be removed from the appliance and the installation base (provided) placed in position.

The appliance can then be lifted into position in the cupboard on top of the base and the front panel removed by unscrewing the 2 screws and lifting the door up and out, ready for connection of the pipework and electrical supplies.

The feed and expansion cistern support shall be installed ensuring that the base is fully supported, the working head of the appliance is not exceeded and the recommended access is provided for maintenance - see the Technical Data section of this manual for details.



Figure 1.6

Pipework Connections

The position of the pipework connections is shown opposite. The exact location dimensions are listed in the Technical Data section of this manual.

All the connections are also labelled on the appliance. It is essential that the pipework is connected to the correct connection.

Connections A and B are plain ended copper pipe.

Connection C and D compression fittings.

Connection E is RC $\frac{1}{2}$ (½ in BSPT internal)

A - 22mm Safety open vent

B - 15mm Cold feed/expansion

C - 22mm Incoming mains cold water

D - 22mm Domestic hot water

E - ½" Drain tap connection

Note: The safety open vent and cold feed/expansion must be connected to the top up cistern using the pipework assembly provided. Do not alter or connect any pressure-relief device to the vent pipe of this water heater.

All factory made joints should be checked after installation in case they have been loosened during transit.

The fittings for the top up cistern should be installed following the instructions provided and the cistern fitted on its supports/top of the appliance.

The cold feed/expansion and safety open vent should be installed between the appliance and the top up cistern.

INSTALLATION

Combined Feed And Open Vent Pipe

It is normally envisaged that the top up cistern will be located in the same cupboard as the PulsaCoil A-Class appliance itself to maintain a dry roof space.

The cold feed/open vent pipework assembly (as supplied) should be used to install the top up cistern directly on top of the appliance.

If it is necessary to locate the cistern in the roof space (or on a higher floor) the cold feed/open vent pipework assembly (as supplied) should be used to connect to the top up cistern and pipework site run by the installer to connect this to the appliance.

Obviously, any pipework in the roof space and the feed and expansion cistern will need to be adequately insulated to protect against frost damage.

Combined Feed And Open Pipe Arrangements Must Not Be Used.

No valves should be fitted in the safety open vent which must be a minimum of 22mm copper pipe or equivalent throughout its length.

The mains cold water supply to the ballvalve (if provided) shall be provided with a suitable servicing valve.

The overflow/warning pipe (if provided) shall have a continuous fall, be fitted to discharge clear of the building and be sited so that any overflow can be easily observed. It shall also be installed in a size and material suitable for use with heating feed and expansion cisterns in accordance with BS 5449 (e.g 22mm copper) and should not have any other connections to it.

Note: If a warning/overflow pipe is NOT provided the top up cistern should be filled from a temporary hose connection supplied from any cold water tap or from a permanent cold branch provided adjacent to the top up cistern. The temporary hose must be fitted with a double check valve and removed once the appliance is filled.

The store may fill more slowly than the feed tank. It is important to check the water level again in the cistern after commissioning.

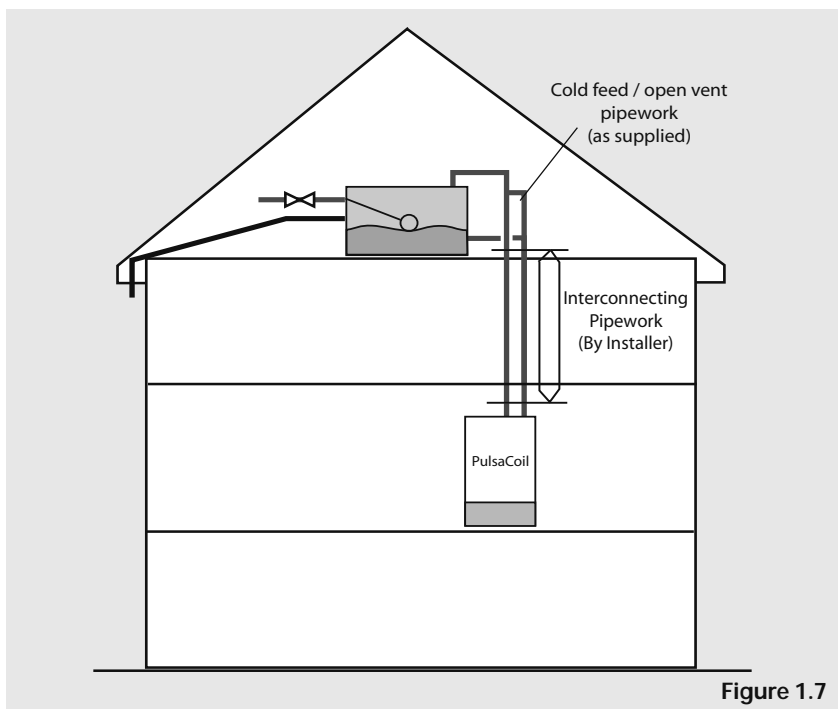

Figure 1.7

Electrical Connection - Standard Appliance

The PulsaCoil A-Class is pre-wired internally, strictly in accordance with the IEE Requirements for Electrical Installations BS 7671. The external wiring/connections should be carried out by a competent person to the same standard. The arrangement of the internal wiring is shown on the previous page.

All the terminals are suitably labelled.

Note: Do not attempt the electrical work unless you are competent to carry it out to the above standards.

Before commencing check that the power source is in accordance with the Site Requirements section of this manual and ensure that it is isolated as shown in the System Details section.

Run the external wiring from the adjacent isolator through the service slot provided in the base of the appliance.

Make the connections as shown below.

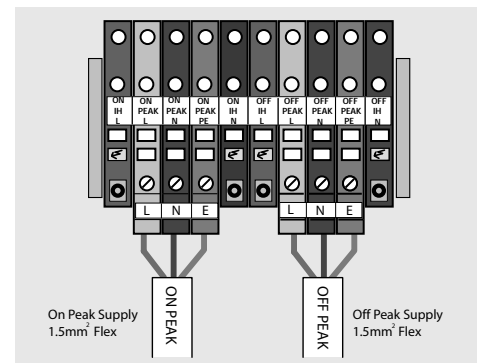

Clamp the cables in the grips provided and ensure all cables are routed to avoid hot surfaces.

Note: The appliance pipework should be bonded to earth to comply with the IEE Requirements for Electrical Installations BS 7671.

Before switching on the electrical supply check all the factory made terminal connections to ensure they have not become loose during transit.

Open the incoming stop valve and fill the domestic mains cold and hot water systems including the PulsaCoil A-Class appliance.

Check the water level in the top up cistern and if a ballvalve is fitted adjust if necessary.

Check the whole of the domestic hot and cold distribution systems for leaks. Fully flush and if necessary chlorinate the hot and cold water system in accordance with the recommendations in the Water Regulations and BS 6700.

Please note that the whole of the domestic hot and cold water systems including the appliance must be adequately flushed after chlorination. Failure to do this can cause damage to the plate heat exchanger/immersion heaters etc. If there are any doubts regarding this or the quality of the water being used to fill the PulsaCoil appliance an inhibitor such as Fernox MBI or Sentinel X100 should be added to the appliance when filling in line with the manufacturers instruction for these products.

Check that the top up tank is filled up to the water level shown on the label. If it is a manual fill model, this is **most important**.

If a ballvalve is provided, turn down the servicing valve once the system is finally filled to the point where the warning/overflow pipe will cope with the discharge arising from a ballvalve failure.

If an overflow is not provided ensure the temporary filling hose is isolated and removed from its connection to the cold water supply.

It is essential that all systems function properly for optimum performance.

To achieve this the flow rate from each tap should be checked and a suitable number of taps run simultaneously to check the impact of this on the flow rate at individual taps.

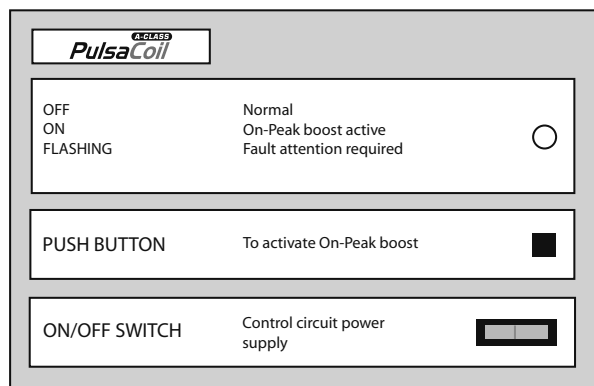

We recommend that flow regulators are provided for each tap/terminal fitting to ensure that the available flow is shared evenly - See Appendix A for further details.

Commissioning the PulsaCoil Control System

Once the PulsaCoil A-Class is filled with water, check the on/off switch on the front is in the off position. The electrical supplies can then be switched on and the switches on the two isolating terminal connectors can be pushed home.

WARNING - Pushing home these switches will complete the electrical circuit to the immersion heaters. DO NOT PUSH HOME THESE SWITCHES AND SWITCH ON THE ELECTRICITY SUPPLY UNTIL YOU HAVE CHECKED THAT THERE IS WATER IN THE F & E CISTERN. Failure to do this can result in dry firing and premature failure of the immersion heaters, which will invalidate the warranty.

Put the on/off switch on the front control panel to the on position to activate the appliance control board. The switch will glow green when in the on position.

If an off peak supply is not available the on-peak boost immersion heater will need to be switched on by pressing the black button. The red light will change to permanently on.

It can be checked that the boost immersion heater is drawing current by use of a clamp meter on the live supply when boost is active or by interrogating the printed circuit control board in accordance with the instructions in the fault finding section of this manual.

The sensor control set points are shown on page 25 and can be checked on the 2 digit ACB display.

The boost immersion heater can be switched off by pressing again the black button.

If an off peak supply is available at the time the appliance is switched on the appliance will automatically switch on the off peak immersion heater. Its operation can be checked in the same way as described above for the on peak immersion heater. When the off peak supply is available the on peak immersion heater operation can still be checked as described above by switching off the off peak supply.

Note: If the on and off peak supplies have been connected wrongly ("crossed") at the appliance it will not operate properly (it may charge if off peak is available but will not carry out any other operations)

If the appliances has been connected with the polarity incorrect it will not operate at all.

See the fault finding section of the manual for further details.

Run a tap and using a digital thermometer check that the temperature of the hot water is about 52°C. This temperature is factory set and is independent of the store temperature assuming the store is above 55°C and typical hot water flow rates of 6-25l/min are being drawn.

This product is covered by the 'Benchmark' scheme and a separate commissioning/service log book is included with this product. This must be completed during commissioning and left with the product to meet the Warranty conditions offered by Gledhill.

SERVICING

Important Do's and Don'ts

1. **DO** check the incoming mains water pressure. The preferred range of mains pressure is 2 -3 bar.
2. **DO** check the flow rate of the incoming cold water main is adequate to meet the maximum hot and cold water simultaneous demands.
3. **DO** check that all connections are in accordance with the labelling on the thermal store.
4. **DO NOT** push home the 2 switches on the isolating terminal connectors and switch on the electricity supply until you have checked that the appliance is full of water i.e. there is water in the top up cistern.
5. **DO** check the water level is correctly set in the top up cistern when cold and if fitted that there is no overflow when the appliance is up to temperature.
6. **DO** check that the sensors switch the immersion heaters off at the correct set point i.e. approx 70°C.
7. **DO** insulate any exposed hot water pipework in the PulsaCoil cupboard.
8. If the ballvalve in the F & E cistern is permanently connected to the mains cold water supply **DO** plumb the overflow/warning pipe in a 20mm internal diameter pipe and ensure it discharges in a conspicuous external position. Use a material which is suitable for use with heating F & E cisterns in accordance with BS 5449 (such as copper).
9. **DO** ensure the green light 'on/off' switch glows.
10. Once the appliance is filled and commissioned **DO** leave the electricity switched on to the appliance to ensure the automatic pump run facility can operate to prevent the pump sticking.
11. **DO** ensure that the functioning and control of the system is explained to the occupant.
12. **DON'T** place any clothing or other combustible materials against or on top of this appliance.

These instructions should be placed along with the component manufacturers instructions in the pocket provided on the rear of the front panel. The front panel should then be refitted.

Annual Servicing

No annual servicing of the PulsaCoil A-Class is necessary.

However, if required, the operation of the controls and a hot water performance test can be carried out to prove the appliance is working satisfactorily and within its specification.

If it is decided to carry out the above tests the water level in the top cistern should also be checked and if necessary topped up.

Changing Components

Free of charge replacements for any faulty components are available from Gledhill during the in-warranty period on return of the faulty part (normally 12 months).

After this, spares can be obtained direct from Gledhill using the 'Speed Spares' service, or through any of the larger plumbers merchants/specialist heating spares suppliers.

Help and advice is also available from the Technical Helpline on 08449 310000.

However, all components are readily accessible and can be changed quickly and easily by the installer using common plumbing/electrical practice.

Note: All maintenance work on the PulsaCoil appliance must be carried out by a competent trades person.

Note:
The pump is a Grundfos UPR 15-50 4 wire pattern and any replacement must be the same model.

	Description	Supplier & Model	Part Number	Stock Code
1	PHE pump	Grundfos, UPR 15-50	5950543	GT089
2	Plate heat exchanger (PHE)	SWEP, 24 Plate heat exchanger	E8T/24	GT017
3	Pump isolating valve - outlet	Watt Industries, 90° valve	7308123	GT135
4	Pump isolating valve - inlet	Watt Industries		GT133
5	Top immersion heater	Shell, 14" Immersion heater - no stat	Incalloy 825	XB083
6	Bottom immersion heater			
7	Main PCB controller	Argus Vision 147/4GS controller	147/4GS	GT490
8	Middle sensor	Tasseron, Single sensor	TSK10B4	GT198
9	Top (OHT) sensor	Tasseron, Duplex sensor	TSK11B4	GT199
10	Front panel display	RH Technical, Membrane overlay	P210328	XB411
11	Front panel display harness	RH Technical, Membrane harness		XB057
12	Off-Peak circuit fuse holder	Phoenix, (Part of DIN rail assembly-non stock item)		
13	Control & off-peak circuit fuses	RS Components, 5A FF	415-626	XB382
14	Off-Peak/On-Peak contactor	Duracool		XB178
15	Bracket	Duracool		XB179
16	Complete DIN rail assembly	Phoenix, Bespoke terminal and component assembly		XB180
17	Complete wiring harness			
18	On-Off switch (part of panel)	Arcoelectric, Green illuminated rocker switch	C5503-ALNAK	CA006
19	DHW inlet & outlet sensors	Tasseron, single sensor complete with nut & olive	Wet pocket sensor, comes as a kit.	GT198 + GT295
20	Relay	Relpol	RM87N-2311-35-5230	XB424
21	DIN rail socket	Relpol	GZT92	XB425



SHORT PARTS LIST

SERVICING

The PulsaCoil A-Class appliance control panel and printed circuit control board/display have been designed to be fully automatic whilst able to provide functional and diagnostic information to the householder/installer.

The panel/board work in conjunction with a number of sensors (thermistors) located as shown in the diagram below.

Automatic Control Operation

Heating of the store is controlled by sensors S1/S2 and S5 and S6. The control set points are shown in the table on page 25.

During normal charging cycle sensor S5 will control the bottom off peak I.H. in the same way S6 will control the top on peak I.H. when manually activated.

In the event of either of these sensors failing, control will be taken over by sensors S1/S2.

Normally, sensors S1/S2 are used to detect an overheat condition (over 95°C) which will cause the red LED on the front control panel to flash (rapid).

This condition should not normally be reached as sensors S1/S2 will also switch off the supplies to the I.H.'s if a temperature above 85°C is detected. Normal operation will automatically resume when the temperature at the sensors drops below 78°C.

The hot water temperature is controlled by sensors S3 and S4.

S3 checks for a drop in temperature every second and if the drop is more than 2°C, it switches on the hot water pump to raise the domestic hot water temperature to 52°C (± 2°C).

The control of the hot water temperature is carried out by sensor S4 adjusting the speed of the hot water pump.

The pump is stopped once S3 reaches a temperature of above 30°C.

The following checks should be carried out by the installer before calling the manufacturer.

Noise When Hot Water Tap Is Opened/closed

If the plate heat exchanger pump is noisy when the hot water tap is opened, then check the level of water in the F & E cistern and vent the pump if necessary.

Water hammer - loose pipework and/or tap washers and/or washing machine valves.

Causes of 'Unsatisfactory Hot Water Service'

See table opposite.

Overflow from Feed and Expansion Cistern

Check that the controlled level of water in the cistern is at the correct level. Adjust if required and check the ballvalve is shutting off the water supply.

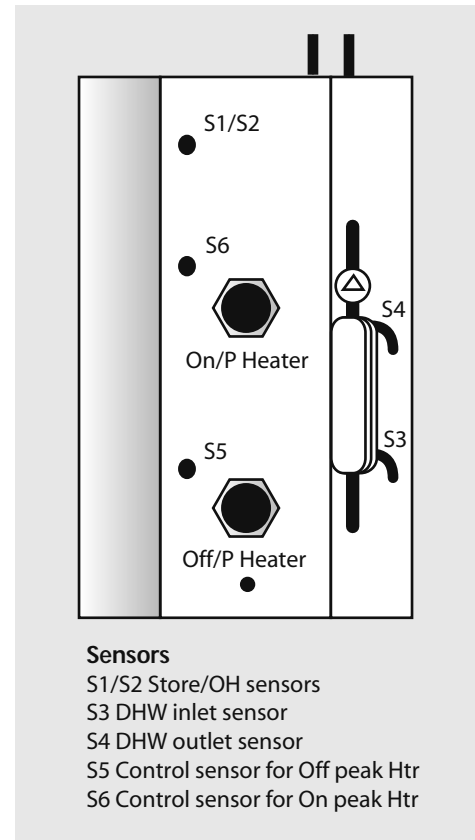

Fault Condition	Possible Causes
DHW temperature remains cold exiting the taps.	<ul style="list-style-type: none"> - Thermal store is cold/DHW pump is permanently stuck - Temperature sensor or printed circuit control board is faulty. - The water level is low in the F&E Cistern - Overheat stat tripped - One or both immersion heaters have failed
DHW temperature fluctuates wildly when flow is steady	<ul style="list-style-type: none"> - DHW pump keeps sticking intermittently - Hot & cold crossed at appliance.
DHW temperature exceeds and remains well above 60°C when the flow rate is low.	<ul style="list-style-type: none"> - DHW printed circuit control board and/or temperature sensor is/are faulty. - Immersion heater thermostat temperature setting too high should be 70°C.
Store not heating	<ul style="list-style-type: none"> - The two switches on the isolating terminal connectors are not pushed home - i.e. unit is not commissioned. - No power supplies/fuses are blown. - Overheat stat has tripped. - One or both immersion heaters have failed.

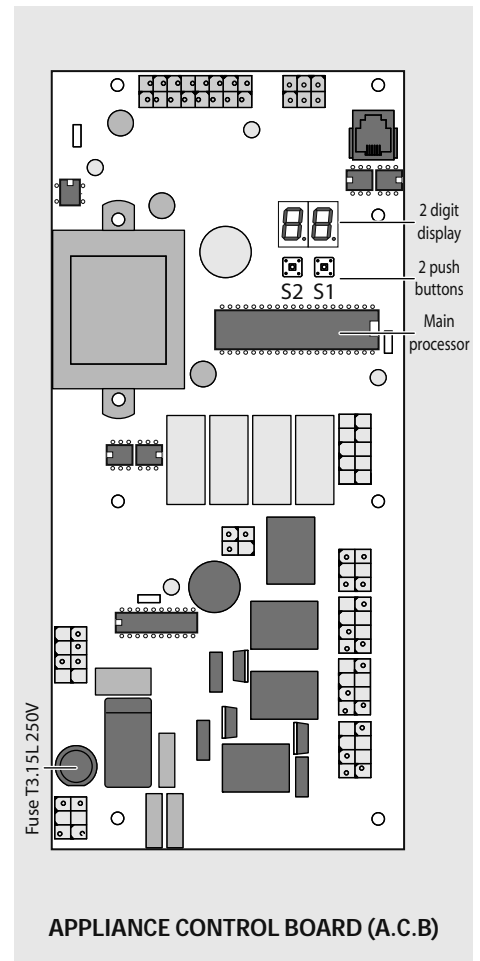
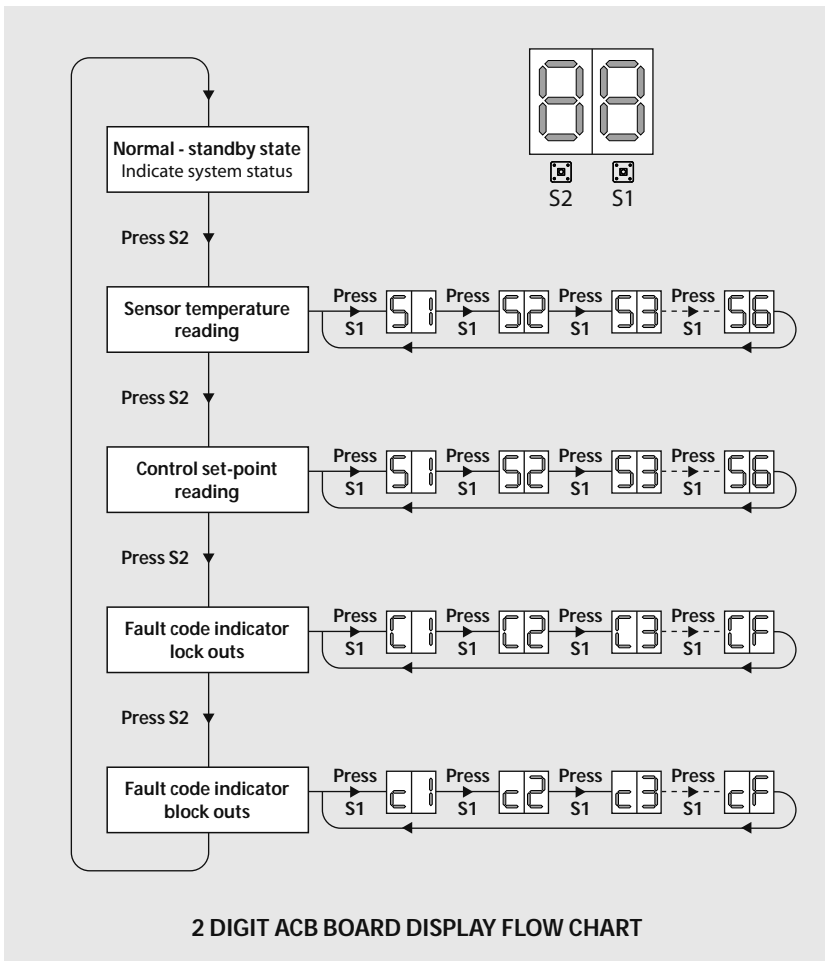

Appliance Control Board

The appliance control board (shown opposite) has a 2 digit display and 2 push buttons which are used to check the status of the appliance, check and set its identity and interrogate it for the current faults and the fault history.

The 2 digit display is controlled by 2 buttons S1 and S2. The flow chart of display modes is shown above. Generally, each press of button S2 cycles the display from top to bottom and each press of button S1 cycles the display functions from left to right.

The button S2 is also used to reset the appliance i.e. clear the lockout errors and reset the appliance. (Note: Appliance resetting can also be carried out using the push button on the front panel)

Note: The board is used on a range of products and not all terminals are used on every appliance.

Display in Normal (Standby) Mode

In the standard/normal mode the 2 digit display indicates the status of the appliance inputs and outputs by switching on the appropriate segments of the display - see page 24 for details.

Appliance Type Selection

The PulsaCoil is fitted with an identity (ID) resistor which is read by the controller for comparison with the appliance type (code) set on the controller. The two must match for the controller/appliance to function. Therefore if either the appliance code setting or the ID resistor is wrong, the appliance will shut down safely and flag the error code until the fault is rectified. The controller codes and the ID resistor values for the PulsaCoil

are 03 and 3K3 respectively. The procedure for checking and setting the appliance code on the controller is described below.

- The appliance selection menu (A0 ... A9) on the controller is hidden. It is only possible to get to the appliance selection using the reset button (Left hand, S2) on the main board.
- When going from the show 'locking error' to show 'blocking error' menu (see opposite), do not release the button but hold it for 10 seconds. The display will change from 'c' to 'A'. At this stage the push button (S2) can be released.
- The appliance type can now be selected by using right hand push button, S1, e.g. for this appliance A03.

Press the reset button, S2, to accept the setting.

If the selected appliance code does not match with the ID resistor fitted to the appliance, then, an error '33' will be displayed.

SERVICING

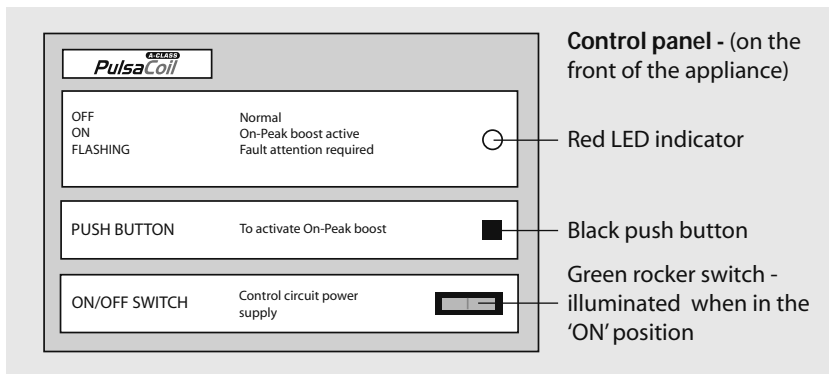

This is designed for operation by the householder and the operation is in line with the instructions on the panel.

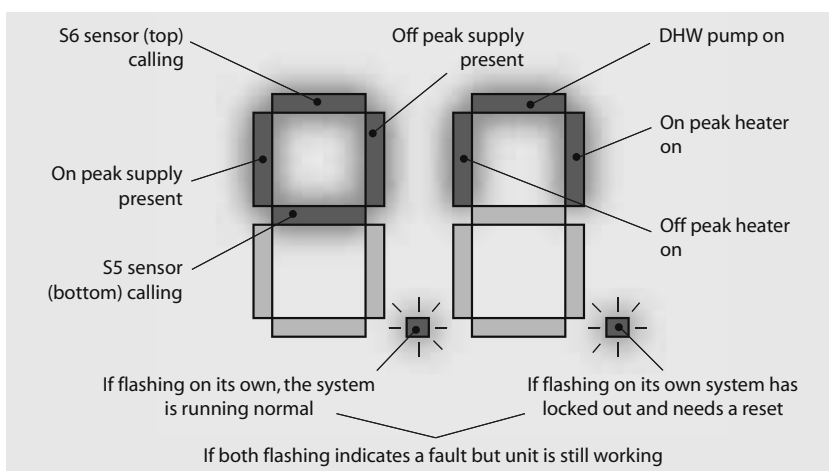

If a sensor error is detected one of the following three error codes flash alternately with the sensor number instead of the temperature

- E1 Open circuit
- E2 Short circuit
- E3 Temperature greater than 99°C

A code of FF indicates the fault location is empty.

Sensor Control Set Points			
S1	Top immersion heater sensor on	(S6)	70°C
S2	Top immersion heater sensor off	(S6)	78°C
S3	DHW in	(S6)	35°C
S4	DHW out	(S6)	52°C
S5	Bottom immersion heater sensor on	(S6)	75°C
S6	Bottom immersion heater sensor off	(S6)	79°C

The set point reading mode is normally only used by the Gledhill engineer to check the sensor set points are still correct. The set point alternately flashes with S1-S6.

See table opposite for set points.

Note: The S1-S6 reference display does not correspond with the S1-S6 sensor references used earlier. These are shown in brackets on the table opposite.

Sensor Control Set Points			
Code		Code	
10	Overheat error	45	S1 overheat 1 shorted
30	Phase error	48	I.D. resistor shorted
33	Appliance selection	49	S4 sensor shorted
37	S1 overheat 1 open	50	S5 sensor shorted
40	I.D. resistor open	51	S6 sensor shorted
41	S4 sensor open	52	S2 overheat 2 shorted
42	S5 sensor open	55	Top IM failure
43	S6 sensor open	56	Bottom IM failure
44	S2 overheat 2 open		
Any other code displayed should be checked against the full chart.			

The two fault code indication modes are again mainly for use by the Gledhill engineer and can only be used with a reference table.

The Blocking errors will clear automatically when the fault is cleared/component changed. The Locking errors can only be cleared by resetting the controller.

In each case there are 16 fault locations stored in date order with C0 being the latest and CF the first.

The most common fault codes are shown opposite. Not all appliances use all the error codes available.

For further assistance please call the Gledhill Technical Helpline on 08449 310000.

Water Savings

Water Related Costs Can Be Reduced By Good Plumbing Practice

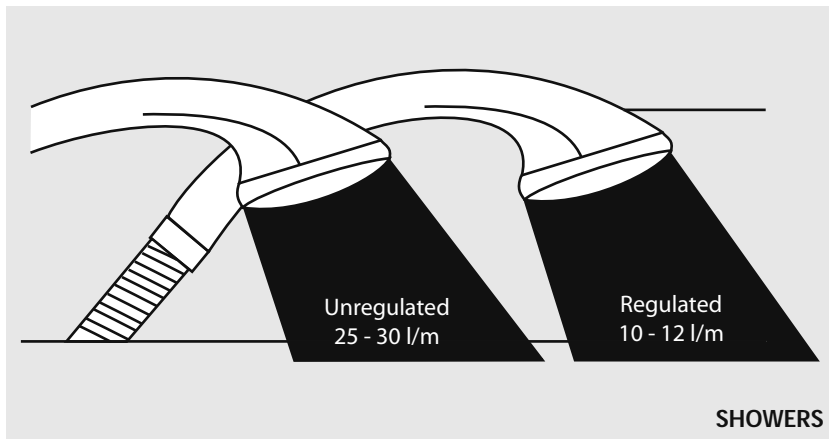
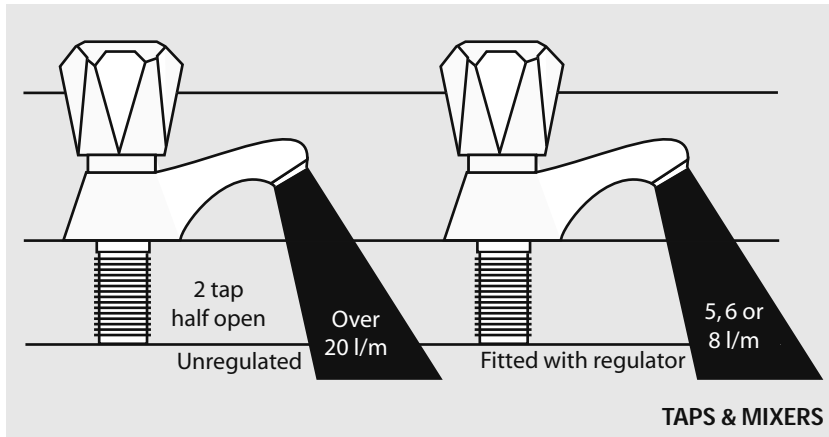

Vast quantities of water are needlessly run off to waste due to Taps, Mixers and Showers discharging flow rates far in excess of the rates required for them to perform their duties.

The contrasting flow rates shown on this leaflet clearly illustrate the savings that can be made whilst still providing a good performance.

British made Aquaflow Regulators provide constant flow rates by automatically compensating for supply pressure changes between 1 bar & 10 bars.

To facilitate installation into the wide range of plumbing equipment which is encountered in the U.K, Four Fixing Options are available:-

Options For Showers

1. MXF "DW" Range - For fitting behind Fixed Shower Heads or onto Flexible Hoses for Handshowers (preferably onto the inlet end when lightweight hoses are used).
2. Compression Fitting Range. "In Line" regulators as in Option 4 for Taps & Mixers.

Information by courtesy of
AQUAFLOW REGULATORS LTD

Haywood House, 40 New Road, Stourbridge, West Midlands DY8 1PA
TELEPHONE (01384) 442611 FAX: (01384) 442612

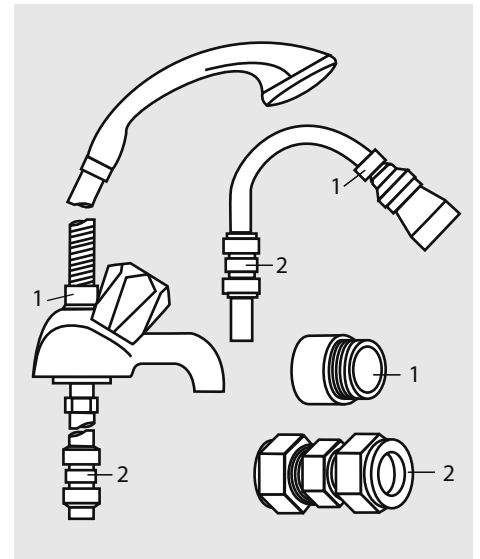

4 Fixing Options For Taps & Mixers

1. MK Range - Combined Regulators & Aerators for screwing onto Taps & Mixers with internal or external threads on their noses. Anti Vandal models also available.
2. MR05-T Range - Internal Regulators. Push-fit into Tap or Mixer seats. Produced in three sizes - 12.5mm (BS1010), 12mm & 10mm, Flangeless models also available for Taps with Low Lift washers.
3. MXF Standard Range - Screw on tail models for Taps & Mixers. Fix onto the tails before fitting the tap connectors. Available in 3/8", 1/2", 3/4" and 1" BSP.
4. Compression Fitting Range - "In Line" regulators housed in 15mm & 22mm CXC Couplers & Isolating Valves. "A" UKWFBS listed by the Water Research Centre. Isolation valves available for slotted screwdriver operation or with coloured plastic handles. Now available also in plastic bodied push-fit couplers & valves.

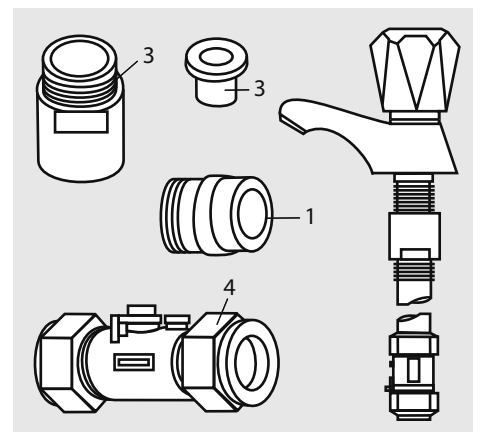

APPENDIX

Manifolds

Manifold type: 1 - Stock Code MIP 050 (one bathroom, one en suite shower room, one cloakroom, one kitchen)			
Flow regulator (litres/minutes)	Terminal fitting	Hot water manifold outlets Quantity	Cold water manifold outlets Quantity
18	Bath tap	1	1
9	Hand basin	3	3
12	Kitchen sink	1	1
9	Toilet cistern	None	3
9	Shower	1	1
12	Washing machine	1	1
9	Dishwasher	None	1
	Total	7	11

Two sets of manifolds are available as an optional extra. Each set comprises a separate hot and cold water manifold. Both are provided with a 22mm inlet connection located centrally. All outlet connections are 15mm compression. The centre to centre dimension of each branch is 55mm.

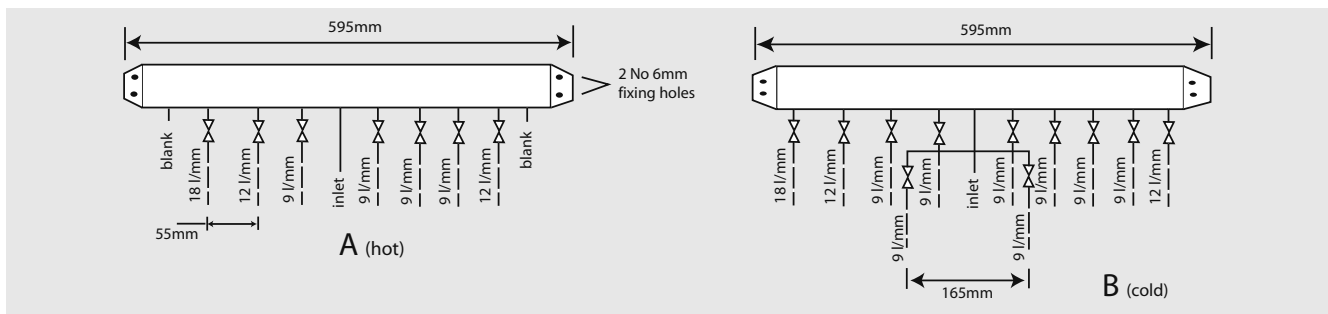

Manifold type: 2 - Stock Code MIP 060 (two bathrooms, one en suite shower room, one cloakroom, one kitchen, one utility room)			
Flow regulator (litres/minutes)	Terminal fitting	Hot water manifold outlets Quantity	Cold water manifold outlets Quantity
18	Bath tap	2	2
9	Hand basin	4	4
12	Kitchen sink	2	2
9	Toilet cistern	None	4
9	Shower	1	1
12	Washing machine	1	1
9	Dishwasher	None	1
	Total	10	15

The arrangement of each manifold is supplied as shown. This provides the best balance of flows but the flow regulators/duty of each branch can be changed if required as long as a reasonable balance is maintained. If it is necessary to change or clean the flow regulator this can be done without needing to drain the system by closing the valve and removing the screwed cover below the white plastic cover.

The manifolds are designed to be used with plastic pipework and are supplied complete with isolation valves and flow regulators on each branch. They would normally be installed in the same cupboard as the thermal storage appliance (as shown below) but can be installed in another cupboard close to the appliance if required.

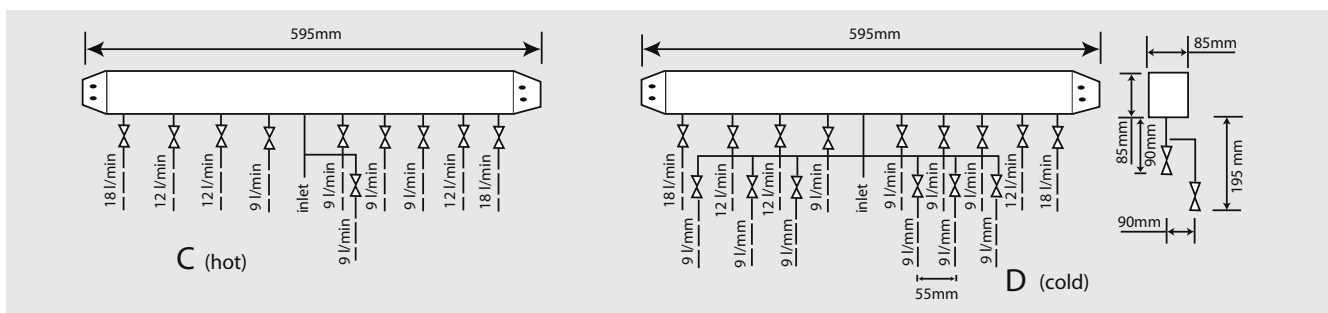



The preferred solution where space will allow



An optional location where cupboard space is tight

The pressure loss through a flow regulator at the designated flow rate is about 1.8 bar. Therefore for the flow regulator to control the flow rate at pre-set level, the inlet pressure must be greater than 1.8 bar. If the inlet pressure is lower, the flow rate will be correspondingly less than the pre-set values.

The maximum equivalent pipe lengths from the manifold to the terminal fittings can be estimated from the above information and the resistance characteristics of the pipes. The examples presented below are for 15mm copper pipe in table 1 and for plastic pipework in table 2.

The size of the distribution pipes supplying the manifold should be calculated using the method set out in BS 6700. A typical diagrammatic arrangement of a system using Manifold Type 1 is shown below.

Table 1: Maximum equivalent pipe length in 15mm copper			
Inlet pressure (bar)	Maximum equivalent length of pipe (m)		
	@ 9 l/m	@ 12 l/m	@ 18 l/m
2.0	25	10	5
2.5	75	30	15
3.0	150	60	30

This is only meant to show the principles involved and the actual connection of fittings to the manifold will need to suit the arrangements shown on page 42.

Note: If it is proposed to fit chemical water treatment such as a water softener this should be fitted in this location and the cold water branch in the sink should be branched off the cold water main prior to the treatment device instead of the cold water manifold.

Table 2: Maximum equivalent pipe length in plastic pipe			
Inlet pressure (bar)	Maximum equivalent length of pipe (m)		
	@ 9 l/m	@ 12 l/m	@ 18 l/m
2.0	1.5	15mm : 10 22mm : 40	15mm : 4.5 22mm : 40
2.5	3.0	15mm : 20	15mm : 9.0 22mm : 80.0
3.0	4.5	15mm : 30	15mm : 13.5 22mm : 120

Any other isolating/control valves and backflow protection devices should be provided as necessary to comply with the Water Regulations.

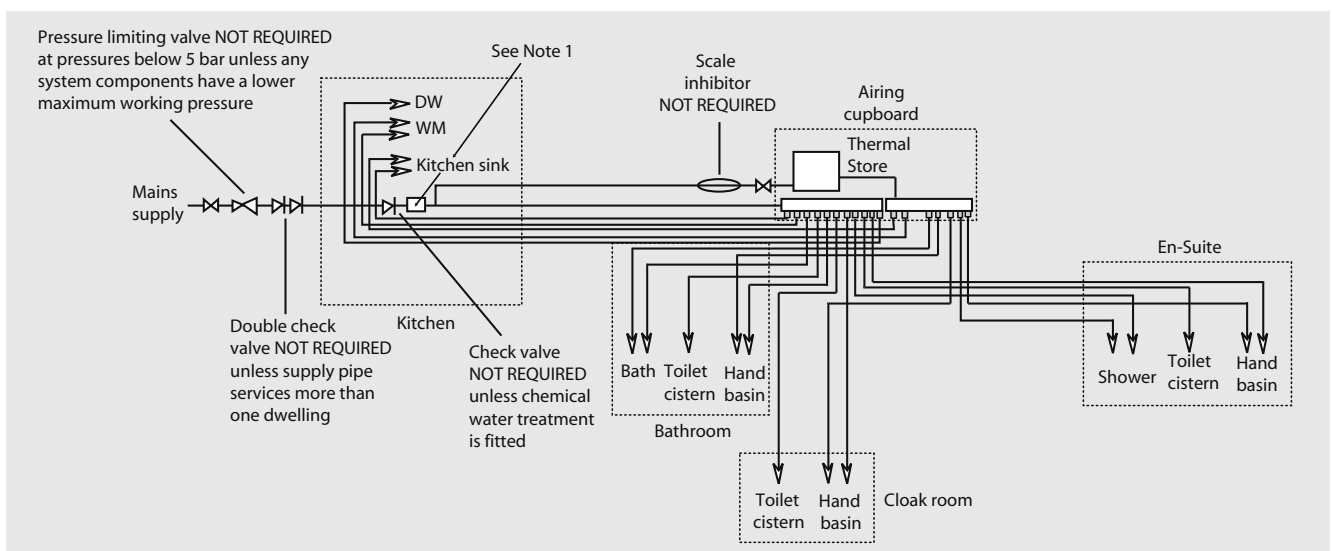



2 Inhibitor (Corrosion & scale protection of primary heating circuit)

On filling the heating system and before the boiler is fired up, it is important to ensure the system water is treated with a suitable corrosion inhibitor, in accordance with the boiler manufacturer's instructions.

Since the concentration of inhibitor present in a system can become diluted, for a number of different reasons, the system should be checked annually and re-treated as required, or after every full or partial drain-down. A water treatment manufacturer's test kit may be used to check the correct concentration of inhibitor in the system.

Where recommended by a boiler manufacturer, a 'physical corrosion protection device' may be fitted in the primary pipework in accordance with the boiler manufacturer's instructions.

The Benchmark log book should be completed indicating the date and details of any of the above products added and a permanent label should be fixed to the system in a prominent location.



3 Scale protection (Domestic hot water service)

Where a combi boiler and/or a hot water storage vessel is installed in areas where the mains water can exceed 200ppm Total Hardness (as defined by BS 7593: 1993 Table 2) a scale reduction device should be installed, in accordance with the boiler manufacturer's instructions.

The levels of water hardness may be measured using a water hardness test kit.

BUILDING REGULATIONS

Completion of the BENCHMARK log book requires that the 'competent person' undertaking the installation and commissioning provide information relating to Cleaning, Inhibitor and Scale Protection. This will demonstrate that the work complies with the requirements of the appropriate Building Regulations.

This Guidance Note is produced on behalf of its members by the Central Heating Information Council. For a full list of members visit www.centralheating.co.uk and for further advice on water treatment contact the following members:

Culligan Sentinel Ferox Salamander Engineering Scalemaster

Heating & Hotwater Information Council, 36 Holly Walk, Leamington Spa, Warwickshire CV32 4LY Tel: 0845 600 2200 Fax: 01926 423284
www.centralheating.co.uk



Benchmark is managed by The Heating & Hotwater Information Council

MANUAL HANDLING OF APPLIANCE PRODUCTS

Description

Manual handling means any transporting or supporting of a load (including lifting, putting down, pushing, pulling, carrying or moving) by hand or bodily force.

Scope

This assessment will cover the largest Appliance, namely ElectraMate, GulfStream, BoilerMate, SysteMate, PulsaCoil, Accolade and Stainless Lite manufactured by Gledhill.

The maximum weight of the largest product in each range is 98kg and the size is 595 x 595 x 2020 mm high.

Main Hazards

Vision may not be clear due to the size of the products. Adopting an incorrect method of lifting may cause injury, attempting to lift these products will require help from others. (Team lifts)

Control Measures

Manual lifting procedure

The lift, key factors in safe lifting are:

- a. **Balance**
 - b. **Position of back**
 - c. **Positioning of the arms and body**
 - d. **The hold**
 - e. **Taking the lead for team lifts**
- a. **Balance** - Since balance depends essentially upon the position of the feet, they should be apart about hip breadth with one foot advanced giving full balance sideways and forward without tension. In taking up this position, lifting is done by bending at the knees instead of the hips and the muscles that are brought into use are those of the thigh and not the back.
 - b. **Position of back** - Straight - not necessary vertical. The spine must be kept rigid, this coupled with a bent knee position, allows the centre line of gravity of the body to be over the weight so reducing strain.
 - c. **Positioning of arms and body** - The further arms are away from the side, the greater the strain on the shoulders, chest and back. Keep elbows close to the body arms should be straight.
 - d. **The hold** - Before lifting ensure you have a good hold. Two handles are provided on Appliance products at the top rear side, these allow one or two persons to have a purposely-designed hold at the top of the appliance to ensure easy lifting at the top of the product. Each appliance is supplied with a pallet, which has been attached to the unit via the packaging. The pallet will also allow for one or two persons to get a good hold.

- e. **Taking the lead for team lifts**- As more than one person is required for these products ensure that one person is taking the lead. **This may be you** so ensure that each person that is helping is made aware of the weight and of the items listed within this assessment. Make sure you and any others helping know the route you intend to take that it is clear of any obstructions. Never jerk the load as this will add a little extra force and can cause severe strain to the arms, back and shoulders. If there are steps involved decide on where you will stop and take a rest period. Move smoothly and in unison taking care to look and listen to others helping with the lift. Where possible use a sack truck to move the product over long flat distances, only lift the products when necessary. If in doubt stop and get more help. The unit handles and packaging with the pallet have been designed to ensure that two-four people can assist when lifting up stairs or over longer distance.

Individual capability

Individual capability plays an important part in handling these products. Persons above average build and strength will find it easier and should be in good health. Persons below average build and strength may require more rest periods during the handling process. Pregnant women should not carry out this operation. Persons who are not in good health should seek medical advice prior to commencing any lifting or manual handling operation.

Residual risk

Following the guidelines given above will reduce any risk to injury. All persons carrying out this operation must be fully trained and copies of the specific risk assessment made available for inspection and use in their training process.

Further guidance on Manual Handling can be obtained from the Health and Safety Executive. Manual Handling Operations Regulations 1992.

Gledhill (Water Storage) Ltd

AMD, JUNE 2008

CONDITIONS OF SALE & GUARANTEE TERMS

1. Gledhill (Water Storage) Ltd ("We" or "Gledhill") only do business upon the Conditions which appear below and no other. Unless we so agree in writing these Conditions shall apply in full to any supply of goods by us to the satisfaction of any Conditions or terms sought to be imposed by any purchaser. These Conditions of Sale and Warranty Terms override those which are contained on the invoice forms and all Sales are made subject to these Conditions of Sale and Warranty Terms only.

2. PRICE

Once an order or call off has been accepted the price will be held for three months but if delivery is estimated beyond that period at the customer's request, then we reserve the right to amend the price when necessary. The company reserves its pricing flexibility to adjust for changes in material costs. We reserve the right to alter prices at any time for various reasons in raw materials (copper and steel). If there is to be a change we will give customers at least four weeks notice but anything delivered after that date will be at the revised price. An order may not be recalled or varied after acceptance without the written consent of the company. Such cancellation or variation shall be subject to such reasonable charges as may be appropriate.

3. SPECIFICATIONS

The goods are supplied in accordance with the Specifications (if any) submitted to the Purchaser and any additions and alterations shall be the subject of an extra charge. Any goods not as specified shall be in accordance with our printed literature or the literature of any of our component suppliers (subject to any modifications made above public offer). If we accept any changes in construction or design of the goods, or in the specifications printed in our literature, the Purchaser shall accept the goods as changed in full and at the price of the order.

4. PAYMENT

The invoice price of goods shall be payable within 30 days of dispatch by us of our invoice for the goods or such longer time as may be stated by our quotation or invoice. If we receive payment in full or balance the due date we will allow an appropriate discount unless agreed when we have quoted a special net price. If payment is not received in full or before the due date we shall be entitled in addition to the invoice price to:

- (i) payment of a sum equal to any increase in the copper price supplement applicable to the particular goods and between the date of receipt of order and the date of receipt of payment in full; and
- (ii) interest on any part of the invoice price unpaid after the due date at the rate of 3% per annum over the base rate for the time being of HSBC Bank plc.

5. TITLE

We give estimates of delivery dates in good faith and time of delivery is not set shall be made of the nature of any contract nor shall we be liable for any loss or damage occasioned by delay in delivery.

6. DELIVERY

We deliver normally by our own vehicles within 25 miles of any of our manufacturing depots. Delivery to any place more than 25 miles from one of our manufacturing depots may be subject to our special delivery charges. We reserve the right to make delivery of goods contained in one order by more than one consignment and at different times. Where a partial is agreed for delivery and such partial is not obtained by our Agreement, the Purchaser shall take delivery within that period. If the Purchaser fails to take delivery, we shall be entitled at the Purchaser's risk and expense to store the goods at the Purchaser's premises or elsewhere and to demand payment as if they had been dispatched. Off loading at point of delivery shall be the responsibility of and to undertake by the Purchaser.

7. INSURANCE OR DAMAGE

Goods sent by insured unless signature of delivery note and any damage, shortage or discrepancy noted on the delivery note and the goods returned on the same vehicle. The buyer must also give us immediate notification of the damage, shortage or discrepancy so that we may prompt investigation.

8. RETURN OF GOODS

Goods may not be returned to the Company except by prior written permission of an authorized officer of the Company and such return shall be subject to payment by the Purchaser of handling and re-stocking charges, transport and all other costs incurred by the Company.

9. COMPANY LIABILITY AND GUARANTEE

9.1. Subject to the terms of these Conditions of Sale and General or Terms Gledhill provide Guarantee in respect of specific products as set out in this clause.

9.2. Each Guarantee is strictly conditional upon the following:

9.2.1. Complaints must be given to us immediately, before any action is taken, as responsibility cannot be accepted if repairs or remedies are attempted on site without our written approval.

9.2.2. The unit has been installed in accordance with manufacturer's and service instructions and all relevant codes of practice and regulations in force at the time of installation.

9.2.3. All necessary inlet controls and safety valves have been fitted correctly.

9.2.4. The unit has only been used for the storage of potable water supplied from the public mains.

9.2.5. Where appropriate the unit has been regularly maintained as detailed in the installation and service instructions.

9.2.6. Defects caused by corrosion or scale deposits are not covered by any Guarantee.

9.2.7. Where we agree to modify any stated we reserve the right to undertake the work on our own premises.

9.3. Guarantees are provided in respect of specified goods supplied by Gledhill as follows:-

(a) Domestic and Commercial Open Ventilated Cylinders and Tanks. The copper storage vessel is guaranteed for ten years and if it proves to be defective either in materials or workmanship, we will either repair or supply replacement at our option with the closest substitute in the case of any obsolete product to any address in Great Britain.

(b) Free of all charge during the first year after delivery by us.

(c) Thereafter at a charge of one-tenth of the then current list price and any copper price supplement and delivery charge during the second year after delivery by us and hereafter by a further one-tenth on the second and subsequent anniversary of delivery by us.

(d) Domestic Water Feed Products (Primary/Secondary)

The copper storage vessel is guaranteed for five years and if it or any integral component as part of the storage vessel assembly proves to be defective either in materials or workmanship, we reserve the right to either repair or supply replacements or the closest possible substitute in the case of any obsolete product and will collect and deliver to any address in England, Wales and Scotland (including all Scottish islands).

(e) Free of all charge during the first year after delivery by us.

(f) Thereafter at a charge of one-tenth of the then current list price or any copper price supplement and delivery charge during the second year after delivery by us hereafter by a further one-tenth on the second and subsequent anniversary of delivery by us.

(g) Integrated Filter and Storage Feed Products and Stand Alone Filters

In the case of the Gledhill range of products and the Gledhill filter range of products, Gledhill guarantees as the best manufacturer (Gledhill) for material and construction faults for two years. THE RESPONSIBILITY FOR THE EXECUTION OF THIS GUARANTEE LIES WITH THE INSTALLER.

The guarantee becomes null and void if the appliance is used incorrectly, or in the event of proven negligence or incorrectly implemented repairs OR FAILURE TO CHECK OUT THE RECOMMENDED INSPECTION/MAINTENANCE. The guarantee also becomes null and void if changes are made to the appliance without our knowledge, or if the serial number on the appliance is missing or made illegible.

The annual service must be carried out by a competent installer in accordance with the advice given by Gledhill and using Gledhill approved parts.

(h) Maximum Hot Water-Cylinder Cylinders. Gledhill guarantees the components including controls, valves and electrical parts for two years from the date of purchase. IT SHOULD BE NOTED THAT THE FACTORY FITTED TEMPERATURE AND PRESSURE RELIEF VALVE MUST NOT BE REMOVED OR ALTERED IN ANY WAY OR THE GUARANTEE WILL NOT BE VALID. GLEDHILL WILL NOT BE RESPONSIBLE FOR ANY CONSEQUENTIAL LOSS OR DAMAGE HOWEVER IT IS CAUSED.

The guarantee for the stainless steel vessel is for twenty five years if the subject unit is returned to us **AND FOLLOWER ITEMS:**

(i) It has been installed as per the Design, installation & Servicing Instructions, relevant standards, regulations and codes of practice.

(ii) It has not been modified, other than by Gledhill.

(iii) It has not been subjected to wrong or improper use or ill treatment etc.

(iv) It has only been used for the storage of potable water.

(v) It has not been subjected to fuel changes.

(vi) The benchmark log book is completed after each annual service.

(vii) The unit has been serviced annually.

It should be noted that the guarantee does not cover:

- the effects of scale build up

- any labour charges associated with replacing the unit or parts.

If the stainless steel vessel proves to be defective either in materials or workmanship we reserve the right to either repair or supply replacements or the closest possible substitute in the case of any obsolete product and will collect and deliver to any address in England, Scotland and Wales (including all islands).

(i) Free of charge during the first year after delivery by us.

(ii) Thereafter at a charge of one-twenty fifth of the then current list price during the second year after delivery by us and increasing by a further one-twenty fifth on the second and subsequent anniversary of delivery by us.

ACTION IN THE EVENT OF FAILURE

If the stainless steel collector develops a leak we will either a disposal against the supply of a new one. This will be intended if the failure is within the term of the warranty when it has been occasioned by us.

(a) Solar Panels and auxiliary equipment

Gledhill provides a five year warranty for defects in the collector (except broken glass and collector accessories eg metal supports). If the collector demonstrably fails to meet one of the requirements of the standard BS1497 part 3 we will replace it free of charge based on the date of invoice. We can not be responsible for damage caused by mechanical stress and/or changes caused by weather related influences.

The warranty excludes other surface damage that does not affect performance or collection due to improper assembly or installation.

Please note

- Installation must have been carried out by a relevant specialist company (installing contractor or plumber) following the version of installation instructions in force.

- Gledhill or its representative can give the opportunity to check complete on site immediately after any defect occurred.

- Installation notes state that the system was commissioned properly and that the system was checked and maintained as performed annually by a specialist company licensed for this purpose.

(b) Components of our products other than Storage Vessels and Integral Pipework.

We will either attend to the purchaser the same terms of warranty as we are given by the manufacturer of the component or if the manufacturer does not give any warranty, replace free of charge any component which becomes defective within five years after the date of the delivery by us and is returned to us at the purchaser's expense but we shall not meet the cost of removal or shipping or return of the component or any other cost charges or damage incurred by the purchaser.

If the appliance manufactured by Gledhill incorporates a factory fitted scale inhibitor then during the period

of these years from the date of delivery. Global will replace, free of charge, any plate heat exchanger fitted in the appliance as original equipment in which a scale formation occurs that materially reduces the effectiveness of the plate heat exchanger. This guarantee does not extend to any other component installed within the Global appliance or elsewhere in the Purchaser's domestic water system.

9.4.

9.4.1. In respect of goods supplied by us and in respect of any installation work carried out by or on our behalf, our entire liability and the purchaser's sole remedy (subject to the Guarantees) shall be as follows:-

- (a) We accept liability for death or personal injury to the extent that it results from our negligence or that of our employees;
- (b) Subject to the other provisions of this clause 9 we accept liability for direct physical damage to tangible property to the extent that such damage is caused by our negligence or that of our employees, agents or subcontractors;
- (c) Our total liability to the purchaser over and above any liability in respect of the Guarantees (whether in contract or in tort including negligence) in respect of any one claim or loss or damage claimed to result from any breach of our obligations hereunder, shall be limited to actual monetary damages which shall not exceed £20,000 provided that such monetary limit shall not apply to any liability on the part of ourselves referred to in paragraph (a) above;
- (d) Except as provided in paragraph (a) above but otherwise notwithstanding any provision herein contained in no event shall we be liable for the following loss or damage to or on our behalf and on our behalf by us or in our contemplation:-
 - (i) economic loss which shall include loss of profits, business revenues, goodwill or anticipated savings;
 - (ii) damage in respect of special interest or consequential loss or damage (other than death, personal injury and damage to tangible property);
 - (iii) any claim made against the purchaser by any other party (save as expressly provided in paragraph (b) above);
- (e) Except in respect of our liability referred to in paragraph (a) above no claim may be made or action brought (whether in contract or in tort including negligence) by the purchaser in respect of any goods supplied by us more than one year after the date of the invoice for the relevant goods;
- (f) Without prejudice to any other term we shall not be liable for any water damage caused directly or indirectly as a result of any leak or other defect in the goods. We cannot control the conditions of use of the goods or the time or manner or location in which they will be installed and the purchaser agrees to be fully responsible for testing and checking all vents which include the goods at all relevant times (pre, during and after commissioning) and for taking all necessary steps to identify any leaks and prevent any damage being caused thereby;
- (g) Nothing in these Conditions shall confer on the purchaser any rights or remedies in which the purchaser would not otherwise be legally entitled.

10. LIMIT OF REMEDY

Notwithstanding any other provision contained herein the purchaser's liability agrees to fully indemnify us against any damage, losses costs claims or expenses incurred by us in respect of any claim brought against us by any third party:-

- (a) any loss injury or damage wholly or partly caused by any goods supplied by us or their use;
- (b) any loss injury or damage wholly or partly caused by the defective installation or subsequent workmanship or materials used in the installation of any goods supplied by us;
- (c) any loss injury or damage in any way connected with the performance of this contract;
- (d) any loss resulting from any failure by the purchaser to comply with its obligations under these terms as to installation and/or check vents correctly.

PROVIDED that this paragraph will not require the purchaser to indemnify us against any liability for our own acts of negligence or those of our employees or agents or subcontractors.

FURTHER in the case of goods supplied by us which are re-sold and identified by a third party by the purchaser it will be the sole responsibility of the purchaser to test the goods immediately after their installation to ensure that later alterations are correctly installed and in proper working order free from leaks and overall likely to cause any loss injury or damage in any process or property.

11. VALIDATION OF MISMAJORITY AND MISTAKE

Should our warranty and remedies be unacceptable we are prepared to negotiate for variation in their terms but only on the basis of an increase in the price to allow for any additional liability or risk which may result from the variation.

Purchasers are advised to insure against any risk or liability which they may incur and which is not covered by our warranty.

12. FORCE MAJEURE AND TITLE

(a) goods supplied by us shall be at the Purchaser's risk immediately upon delivery to the Purchaser or into custody on the Purchaser's behalf or in the Purchaser's Docks. The Purchaser shall effect adequate insurances of the goods against all risks in the full invoice value of the goods, such insurances to be effective from the time of delivery until property in the goods shall pass to the Purchaser as hereinafter provided.

(b) property in the goods supplied hereunder will pass to the Purchaser when full payment has been made by the Purchaser to us for:-

- (i) the goods of the subject of this contract;
- (ii) all other goods the subject of any other contract between the Purchaser and us which, at the time of payment of the full price of the goods sold under this contract, have been delivered to the Purchaser but not paid for in full.

(c) until property in the goods supplied hereunder passes to the Purchaser in accordance with paragraph (b) above:

- (i) the Purchaser shall hold the goods in a fiduciary capacity for us and shall store the same separately from any other goods in the Purchaser's possession and in a manner which enables them to be identified as our goods;
- (ii) the Purchaser shall immediately return the goods to us should our authorised representative so request. All the necessary incidents associated with a fiduciary relationship shall apply.

(d) the Purchaser's right to possess the goods shall cease forthwith upon the happening of any of the following events, namely:-

- (i) if the Purchaser fails to make payment in full for the goods within the time stipulated in clause 4 hereof;
- (ii) if the Purchaser, not being a company, commits any act of bankruptcy, makes a proposal to its or her creditors for a composition or does anything which would entitle a petition for a Bankruptcy Order to be presented;
- (iii) if the Purchaser, being a company, does anything or fails to do anything which would entitle an administrator or an administrative receiver or a receiver to take possession of any assets or which would entitle any person to present a petition for winding up or to apply for an administration order;
- (iv) the Purchaser sends goods to us as bauxite to be used in or at any time any vehicle or premises owned or occupied by the Purchaser or in the possession of the Purchaser for the purpose of representing and

receiving any such goods the property in which has been assigned in or under paragraph (c) above. We shall not be responsible for and the Purchaser will indemnify us against liability in respect of damage caused in any vehicle or premises in such representation and removal being damaged which it was not reasonably practicable to avoid.

(e) notwithstanding paragraph (b) hereof and subject to paragraph (7) hereof, the Purchaser shall be permitted to sell the goods to third parties in the normal course of business. In this regard the Purchaser shall act in the capacity of our commission agent and the purchaser of such goods:-

- (i) shall be held in trust for us in a manner which enables such purchaser to be identified as such, and;
- (ii) shall not be mixed with other monies or paid into an overdraft or bank account.

We, as principal, shall reimburse the Purchaser on commission equal to a commission depending upon the supplier which the Purchaser can obtain over and above the sum stipulated in this contract of supply which will satisfy us.

(f) in the event that the Purchaser shall sell any of the goods pursuant to clause (e) hereof, the Purchaser shall forthwith inform us in writing of such sale and of the identity and address of the third party to whom the goods have been sold.

(g) if, before property in the goods passes to the Purchaser under paragraph (b) above the goods are or become attached to any land or building owned by the Purchaser it is hereby agreed and declared that such attachment shall not have the effect of passing property in the goods to the Purchaser. Furthermore if, before property in the goods shall pass to the Purchaser under paragraph (b) hereof, the goods are or become attached to any land or building (whether or not owned by the Purchaser), the Purchaser shall:-

- (i) ensure that the goods are capable of being removed without material injury to such land or building;
- (ii) take all necessary steps to prevent title to the goods from passing to the tenant of such land or building;
- (iii) forthwith inform us in writing of such attachment and of the address of the land or building concerned.

The Purchaser warrants to repair and make good any damage caused by the attachment of the goods to or their removal from any land or building and to indemnify us against all loss damage or liability we may incur or sustain as a result of attachment or removal.

(h) in the event that, before property in the goods has passed to the Purchaser under paragraph (b) hereof, the goods or any of them are lost, stolen, damaged or destroyed:-

- (i) the Purchaser shall forthwith inform us in writing of the fact and circumstances of such loss, theft, damage or destruction;
- (ii) the Purchaser shall assign to us the benefit of any insurance claim in respect of the goods so lost, stolen, damaged or destroyed.

13. NON-PAYMENT

If the Purchaser shall fail to make full payment for the goods supplied hereunder within the time stipulated in clause 4 hereof or to its default of payment for any other reason then, without prejudice to any of our other rights hereunder, we shall be entitled to stop all deliveries of goods and materials to the Purchaser, including deliveries or further deliveries of goods under this contract. In addition we shall be entitled to prosecute all outstanding orders.

14. UNLAWFUL TAX

All prices quoted are exclusive of Value Added Tax which will be charged at the rate of 20% at the date of dispatch of invoices.

15. WHOLESALE ONLY

We are only prepared to deal with those who are not consumers within the terms of the Unfair Contract Terms Act 1977, the Sale of Goods Act 1979 and the Supply of Goods and Services Act 1982. Accordingly any person who purchases from us shall be deemed to have represented that he is not a consumer by so purchasing.

16. JURISDICTION

This agreement is subject to English law for contracts concluded in England and Scottish law for contracts concluded in Scotland and any dispute hereunder shall be settled in accordance therewith dependent upon the location.



*The code of practice for the installation,
commissioning & servicing of central heating systems*



Gledhill
The appliance of innovation