

**A-CLASS**

# *ElectraMate*

## DESIGN, INSTALLATION AND SERVICING INSTRUCTIONS

Model Numbers

EMA 225/6/E10  
EMA 225/9/E10  
EMA 225/6/MT  
EMA 225/9/MT



*The code of practice for the installation,  
commissioning & servicing of central heating systems*

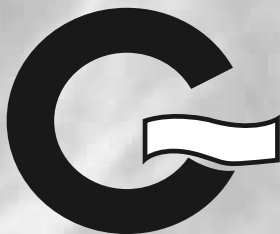

**A COMBINED PRIMARY STORAGE UNIT (CPSU) FOR  
DOMESTIC HOT WATER SUPPLY AND CENTRAL  
HEATING UTILISING OFF-PEAK ELECTRICITY**

**ALL MODELS COMPLY WITH THE  
WATER HEATER MANUFACTURERS SPECIFICATION  
FOR INTEGRATED THERMAL STORES**

# CONTENTS

## IMPORTANT INFORMATION

### ElectraMate A-Class and Off-Peak Electricity Tariffs

There are a number of different 'OFF PEAK' tariffs available from the electrical utilities, which vary, in their precise operation.

To ensure the correct operation and to minimise the running costs it is ESSENTIAL that the ElectraMate A-Class is connected to a suitable UNRESTRICTED OFF-PEAK ELECTRICITY TARIFF.

THE UNRESTRICTED ECONOMY 10-HOUR TARIFF (E10) IS STRONGLY RECOMMENDED AND IS WIDELY AVAILABLE THROUGHOUT THE UK. This is the only tariff currently recognised within SAP Building Regulations.

**If there is no alternative to using a RESTRICTED tariff then an optional multi tariff (MT) version of ElectraMate A-Class is available incorporating significant additional control equipment at an extra charge. However, the heating and hot water service may be reduced with a restricted tariff and it may also cost more to run.**

THIS APPLIANCE IS SOLD ON THE UNDERSTANDING THAT A SUITABLE UNRESTRICTED OFF-PEAK TARIFF IS AVAILABLE AND THE E10 MODEL WILL BE SUPPLIED UNLESS THE MT MODEL IS ORDERED SPECIFICALLY.

Please contact your electricity provider to determine which off-peak tariff is available. If there are any queries then please contact our TECHNICAL HELPLINE on 08449 310000.



*The code of practice for the installation,  
commissioning & servicing of central heating systems*

### Building Regulations and Benchmark Commissioning

The Building Regulations (England & Wales) require that the installation of a heating appliance be notified to the relevant Local Authority Building Control Department. From 1st April 2005 this can be achieved via a Competent Person Self Certification Scheme as an option to notifying the Local Authority directly. Similar arrangements will follow for Scotland and will apply in Northern Ireland from 1st January 06.

CORGI operates a Self Certification Scheme for gas heating appliances.

These arrangements represent a change from the situation whereby compliance with the Building Regulations was accepted if the Benchmark Logbook was completed and this was then left on site with the customer).

With the introduction of a self certification scheme, the Benchmark Logbook is being replaced by a similar document in the form of a commissioning check list and a service interval record is included with all gas appliance manuals. However, the relevant Benchmark Logbook is still being included with all Thermal Storage products and unvented cylinders.

Gledhill fully supports the Benchmark aims to improve the standards of installation and commissioning of central heating systems in the UK and to encourage the regular servicing of all central heating systems to ensure safety and efficiency.

Building Regulations require that the heating installation should comply with the manufacturer's instructions. It is therefore important that the commissioning check list is completed by the competent installer. This check list only applies to installations in dwellings or some related structures.

## ISSUE 5: 06-08

Section	Page
<b>1.0 DESIGN</b>	
1.1 Introduction	
1.2 Technical Data	
1.3 System Details	
<b>2.0 INSTALLATION</b>	
2.1 Site Requirements	
2.2 Installation	
2.3 Commissioning	
<b>3.0 SERVICING</b>	
3.1 Annual Servicing	
3.2 Changing Components	
3.3 Short Parts List	
3.4 Fault Finding	
Appendix A	
Appendix B	
Appendix C	
Appendix D	
Terms & Conditions	

**The Gledhill ElectraMate range is a WBS listed product and complies with the WMA Specification for integrated thermal storage products. The principle was developed in conjunction with British Gas. This product is manufactured under an ISO 9001:2000 Quality System audited by BSI.**

### Patents Pending

**The Gledhill Group's first priority is to give a high quality service to our customers.**

**Quality is built into every Gledhill product and we hope you get satisfactory service from Gledhill.**

**If not please let us know.**

# 1.0 DESIGN

## 1.1 INTRODUCTION

Any water distribution and central heating installation must comply with the relevant recommendations of the current version of the Regulations and British Standards listed below:-

### Building Regulations

I.E.E. Requirements for Electrical Installations - BS 7671 : 1992

### Water Regulations

### British Standards

BS6798, BS5449, BS5546, BS5440:1, BS5440:2, CP331:3, BS6700, BS5258, BS7593 and BS7671.

Although the domestic water supply to the ElectraMate A-Class is at mains pressure, it is not necessary to fit an expansion vessel, pressure or temperature relief valve.

The design of the ElectraMate A-Class means that it has an open vented store but is only suitable for use with sealed primary central heating systems.

A suitably competent person must install the Electramate A-Class and carry out any subsequent maintenance/repairs. In fact, the front panel is secured by 2 screws, and should only be removed by a competent trades person. The manufacturers notes must not be taken as overriding statutory obligations.

The ElectraMate A-Class is not covered by section G3 of the current Building Regulations and is therefore not notifiable to Building Control specifically for this reason.

The ElectraMate A-Class is not intended for use by persons (including children) with reduced physical, sensory or mental capabilities, or lack of experience or knowledge, unless they have been given supervision or instruction concerning use of the appliance by a person responsible for their safety.

Children should be supervised to ensure that they do not play with the appliance.

The information in this manual is provided to assist generally in the selection of equipment. The responsibility for the selection and specification of the equipment must however remain that of the customer and any Designers or Consultants concerned with the design and installation.

**Please Note:** We do not therefore accept any responsibility for matters of design, selection or specification or for the effectiveness of an installation containing one of our products unless we have been specifically requested to do so.

All goods are sold subject to our Conditions of Sale and Warranty Terms, which are set out at the rear of this manual.

In the interest of continuously improving the ElectraMate range, Gledhill Water Storage Ltd reserve the right to modify the product without notice, and in these circumstances this document, which is accurate at the time of printing, should be disregarded. It will however be updated as soon as possible after the change has occurred.



# 1.0 DESIGN

ElectraMate hydraulic circuit arrangement  
for 9kW Model

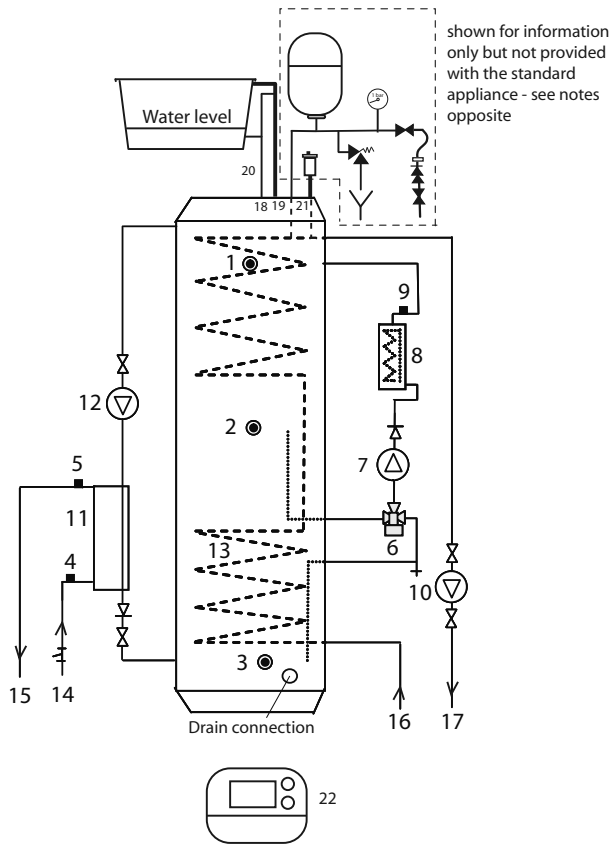

## 1.1 INTRODUCTION

The diagrams opposite/below show the arrangement of the standard ElectraMate A-Class appliances which are supplied with an F & E cistern without a ballvalve/overflow connector (ie suitable for manual filling) These can be supplied and fitted by the installer if preferred.

Because this product does not require a safety discharge from a temperature and pressure relief valve, any installations will be easy to incorporate into the building and will not suffer from the problems associated with using PVCu soil stacks to take the discharge from unvented cylinders.

An expansion vessel, automatic air vent, filling loop, pressure gauge and expansion relief valve (ERV) will be required for the sealed heating system. These are available as an optional Primary Expansion Kit if required at extra cost.

ElectraMate hydraulic circuit arrangement  
for 6kW Model

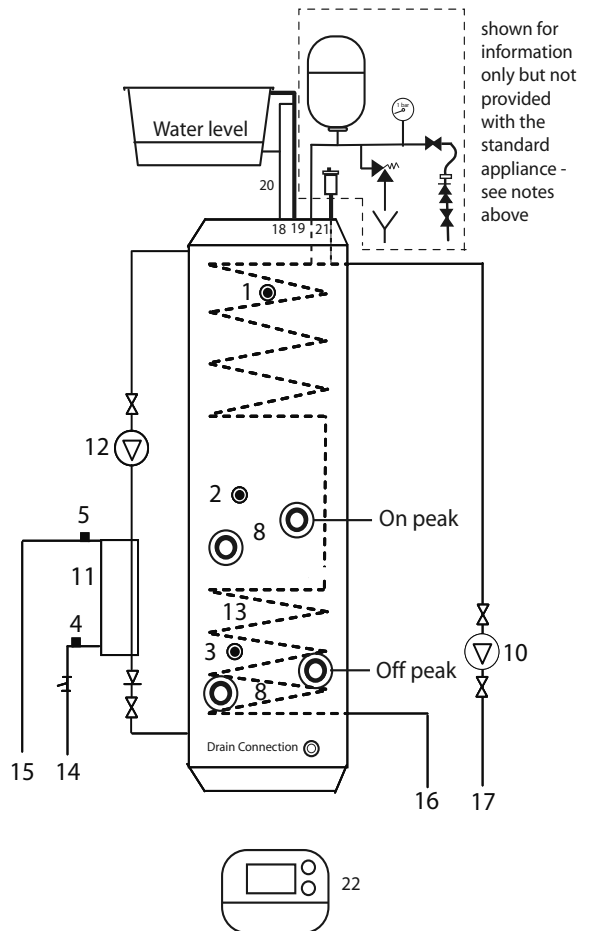

### Key to Schematic (included on/with the appliance)

1	Overheat thermostats, S1& S2 :T_overh_1 & T_overh_2
2	Middle store sensor, S6 :T_store_middle
3	Bottom store sensor, S5 :T_store_bottom
4	Cold water inlet sensor, S3 :T_DHW_IN
5	Hot water outlet sensor, S4 :T_DHW_OUT
6	3 - port diverter valve (J29) (9kW only)
7	Electric boiler pump (J32) (9kW only)
8	Electric boiler/heaters (J3)
9	Mechanical Overheat Thermostat - self resetting (9kW only)
10	Central heating pump (J33)
11	Plate heat exchanger (PHE)
12	PHE circuit pump (J34)
13	CH heat exchanger
14	Cold water inlet connection with integral strainer and flow regulator
15	Hot water outlet connection
16	Central heating return connection
17	Central heating flow connection
18	Cold feed (primary store) connection
19	Open vent (primary store) connection
20	Feed and expansion cistern with cold feed /open vent pipework assembly
21	Central heating automatic air vent (AAV)
22	Danfoss TP5000 Programmable room thermostat

## 1.1 INTRODUCTION

These will need to be connected to the pipe connections provided on the top of the appliance as shown opposite.

The Primary Expansion Kit should be fitted at a position which allows the ERV discharge pipe to be run easily to a suitable discharge point in the normal way.

The ElectraMate A-Class has been designed to utilize the latest technology to provide mains pressure hot water and traditional wet central heating from conventional radiators utilising off-peak electricity.

For optimum efficiency it is important that the best unrestricted off-peak tariff is available, and a minimum of an Economy 10 tariff is strongly recommended. See important information on page 2 and the Model Selection Table in 1.2 Technical Data for further details.

The ElectraMate A-Class is controlled by a microprocessor based PCB and operates as follows.

### Charging of the thermal stores

The electronic sensors monitor the store temperature and when the store is depleted the controller starts the recharge cycle giving priority to times when off-peak electricity is available. When the controls are enabled to recharge the store the boiler pump (9kW only) and heaters are switched on and these continue to run until the store sensors are satisfied.

To keep running costs to a minimum the control system automatically selects the store charge temperature dependant on whether it is an on or off peak period i.e. it reduces the temperature during the on peak periods. To further reduce runnings costs only the top half of the thermal store is heated during on peak periods.

### Space Heating Operation

The operation of the space heating is controlled by user controls. A programmable room thermostat is provided loose for this purpose. When there is a demand for space heating from the programmable room thermostat the ElectraMate A-Class control system starts the space heating pump which circulates the preheated hot water from the store to the radiators. The space heating pump continues to run as long as the heat demand signal is present from the user controls unless there has been a high demand for hot water. In these circumstances the central heating pump will be shut down to give priority to the hot water.

A Grundfos UPS 15-50 pump is fitted as standard for the central heating circuit and Grundfos UPR 15-50 modulating pump is available as an optional extra item.

### Domestic Hot Water Operation

An important feature of this concept is that hot water can be supplied directly from the mains at conventional flow rates without the need for temperature and pressure relief safety valves or expansion vessels. This is achieved by passing the mains cold water through a plate heat exchanger (PHE), which is then heated instantaneously by the primary water from the thermal store being circulated by the dedicated pump in contraflow through the PHE.

The outlet temperature of the domestic hot water is maintained at a pre-set level (normally about 52°C at 18 litres/min) by an electronic PCB controller (ACB), which regulates the speed of the pump circulating the primary water from the store through the plate heat exchanger.

The Building Regulations L1A: New dwellings/L1B: Existing dwellings and the requirements set out in the Domestic Heating Compliance Guide specify that "where the mains water hardness exceeds 200ppm provision should be made to treat the

feed water to water heaters and the hot water circuit of combination boilers to reduce the rate of accumulation of lime scale".

To comply with this requirement the hardness of the mains water should be checked by the installer and if necessary the optional factory fitted electronic in-line scale inhibitor should be specified at the time of order for hardness levels between 200 and 300 ppm (mg/l).

Where the water is very hard ie 300ppm (mg/l) and above the optional polyphosphate type inhibitor should be specified at the time of order. However, this will need to be fitted by the installer at a suitable point in the cold water supply to the appliance.

If scale should ever become a problem the plate heat exchanger is easily isolated and quickly replaced with a service exchange unit which can be obtained at a nominal cost from Gledhill. For further details see Section 1.3 Use in Hard Water Areas.

# 1.0 DESIGN

## 1.2 TECHNICAL DATA

Technical Specification				
Model Reference			EMA 225/6	EMA 225/9
Storage volume	Nominal storage capacity, V1	(litres)	200	200
	On peak storage capacity, V2	(litres)	100	100
Appliance weight	Empty	(kg)	90	90
	Full	(kg)	290	290
Heating circuit expansion volume (1)	4kW design heat load	(litres)	0.84	0.84
	6kW design heat load	(litres)	1.20	1.20
Feed & expansion cistern (2)	Thermal store	(litres)	9.0	9.0
Maximum working head	Thermal store - Open vented only	(mWG / bar)	10.0m / 1.0 bar	
	Central heating circuit	(mWG / bar)	30.0 m / 3.0 bar	
Cold water mains supply dynamic pressure	Minimum	(bar)	1.0: HW supply & dist will be poor	
	Recommended	(bar)	2-3: For good hot water service	
	Maximum	(bar)	5 or above : Fit PRV set at 3.0 bar	
Time to heat store from 10°C to 80°C	Nominal storage volume, V1	(hours)	2 hr 42 mins	1 hr 42 mins
	On-peak storage volume, V2	(hours)	1 hr 38 mins	1 hr 10 mins
Hot water draw-off volume at 35K temperature rise @ 25 l/min (3) from a store at maximum charge level (off peak condition)		(litres)	200	200
Hot water draw-off volume at 35K temperature rise @ 25 l/min (4) from a store at minimum charge level (on peak condition)		(litres)	90	90
Electrical Data				
			EMA 225/6	EMA 225/9
24 hour (on-peak) electricity supply and rating			230V, ~50Hz Rated at 6,200W	230V, ~50Hz Rated at 9,200W
Interruptible Off-Peak supply and rating (5)			230V, ~50Hz Rated at 200W	230V, ~ 50Hz Rated at 200W
Maximum power consumption (6) @ 230V, ~ 50Hz		(W)	6,200	9,200
Standby power consumption (7) @ 230V, ~ 50Hz		(W)	60	60
Internal circuit protection - Control circuit supplied from the 24h continuous supply to the appliance			1 x 6A mcb Type B	1 x 6A mcb Type B
Internal circuit protection - Electric boiler			2 x 16A mcb Type B	2 x 20A mcb Type B

1. A typical central heating expansion volume has been used for sizing the optional central heating circuit expansion vessel. However, the heating system designer should calculate the correct system volume and check that the size of the expansion vessel provided is adequate.
2. The feed and expansion cistern has been sized to accommodate the expansion volume of the thermal store. If the cistern is not fitted with a ball valve and overflow pipe, then it is recommended that the water level in the feed and expansion cistern should be set to the level shown on the label provided.
3. Based on an average store temperature of 80°C i.e. fully charged and stratified thermal store and mains cold water inlet temperature of 10°C.
4. Based on average store temperature of 72°C (top 50% of store) and bottom 50% of store depleted to below 40°C and at mains cold water inlet temperature of 10°C.
5. Only used as signal to indicate that the off-peak supply/tariff is available.
6. Maximum on-peak or off-peak power consumption when the appliance is charging and all other controls (e.g. pumps etc) are active.
7. Control circuit is supplied from the 24h power supply to the appliance and standby power consumption refers to the period when the appliance is in standby mode.

# 1.0 DESIGN

## 1.2 TECHNICAL DATA

Model Selection Data Table				
Electricity Supply Tariff (2 most popular shown - for others please consult our Technical Department)	Max Design Heat Loss of dwelling (kw)			
	EMA 225/6/E10	EMA 225/9/E10	EMA 225/65/MT	EMA 225/95/MT
7 hour night time unrestricted off peak Economy 7 <b>(not recommended)</b>	3.0	3.5	-	-
10 hour unrestricted off peak 5 hour night time, 3 hour afternoon and 2 hour evening eg Economy 10 <b>(recommended)</b>	4.0	5.0	-	-
18 hour restricted off peak tariff - 24 hour other than 3 x 2 hour periods when NO power supplies are allowed (eg Economy 2000) <b>(not recommended)</b>	-	-	4.0	5.0
Maximum number of bathrooms/shower rooms	1 / 1	1 / 2	1 or 1	1 / 1

# 1.0 DESIGN

## 1.2 TECHNICAL DATA

Standard Unrestricted 9kw (Economy 10) Control Panel

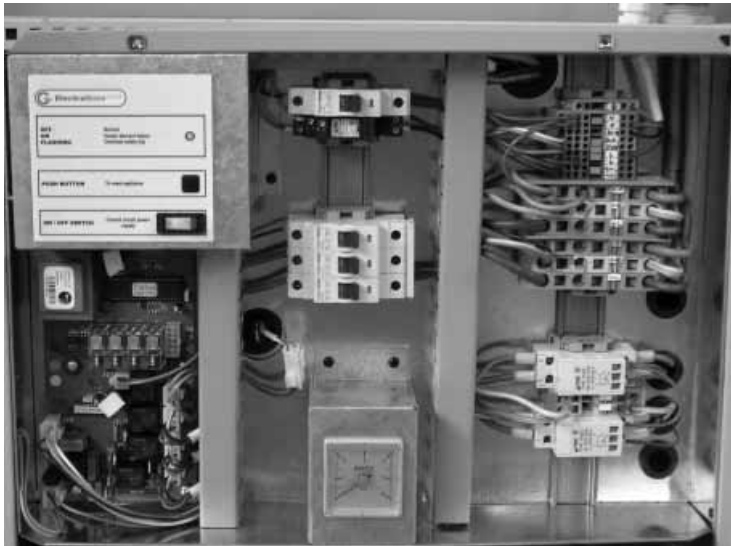

### Standard Equipment

The standard configuration of the ElectraMate A-Class E10 and MT control panels are shown opposite. It is supplied with the following factory fitted equipment:

### Standard Equipment:

- Electric boiler/heaters
- Grundfos UPR 15-50 Modulating Pump for integral boiler (9kW only)
- Grundfos UPS 15-50 Pump central heating
- Grundfos UPR 15-50 Modulating Pump for integral DHW
- ACB control PCB and wiring panel
- Programmable room thermostat (supplied loose)
- Plate heat exchanger
- 5 Integral Temperature sensors
- Electrical switch gear / Installer connections
- Manual fill feed & Expansion cistern
- Prefabricated interconnecting pipework between F & E cistern/appliance
- 3 port diverter valve (9kW only)

**Note:** The Appliance Control Board (A.C.B.) mounted inside the appliance, controls the operation of the complete system.

Restricted 9kw (Multi Tariff) Control Panel

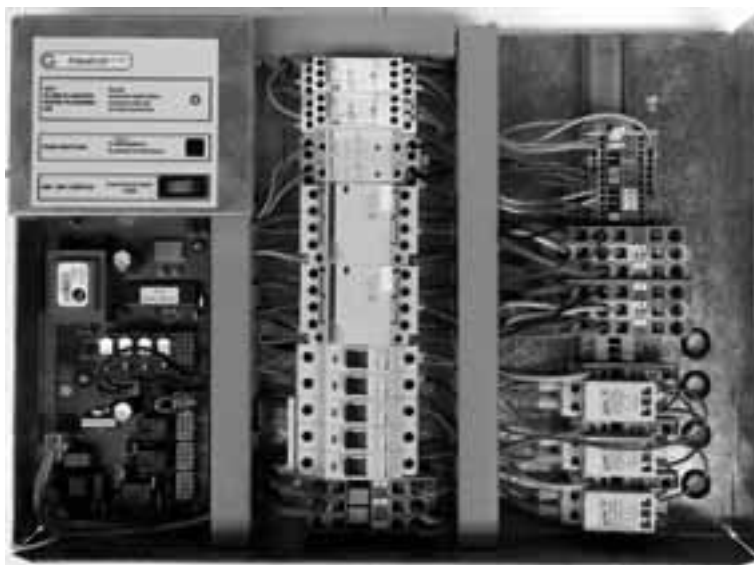

TP5000

Programmable room thermostat supplied as standard with all models



### Optional Equipment:

- Hot and cold water manifolds
- Factory fitted electronic scale inhibitor for water services with hardness levels between 200ppm and 300ppm.
- Polyphosphate type scale inhibitor for water services with hardness levels above 300ppm (for fitting elsewhere in the system by the installer).
- Primary expansion kit comprising 12 litre expansion vessel, automatic air vent, filling loop, pressure gauge and expansion relief valve for sealed heating system.
- Modulating central heating pump (Grundfos UPR 15-50).
- 4 pole electrical isolator box



# 1.0 DESIGN

## 1.2 TECHNICAL DATA

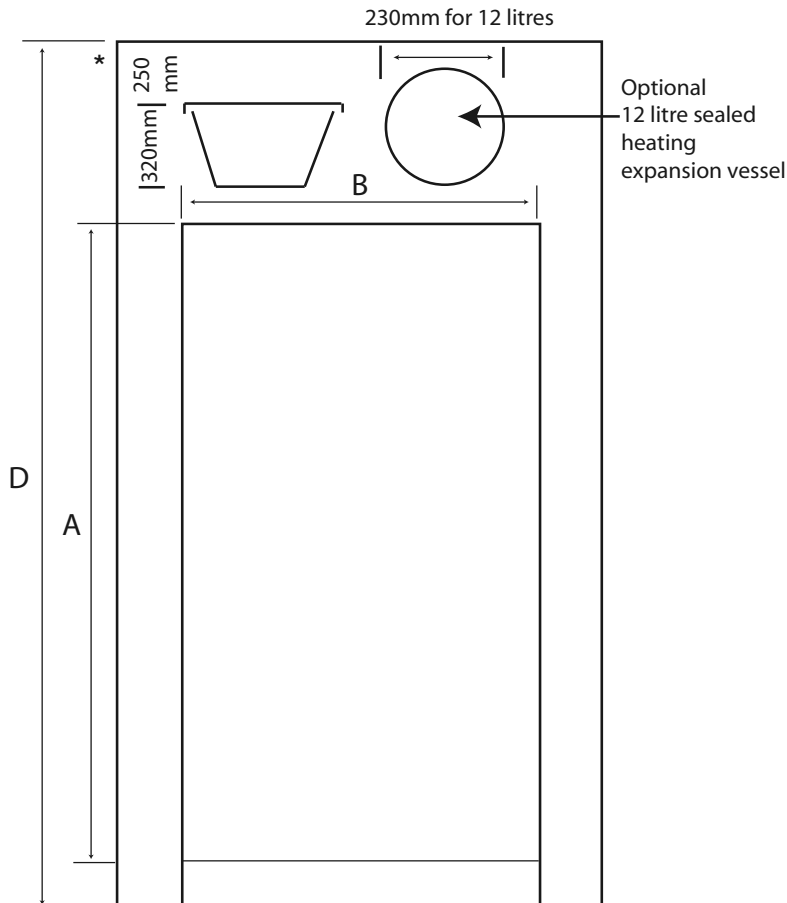

APPLIANCE DIMENSIONS			
	Height	Width	Depth
Model	A	B	C
Both	1550mm	530mm	610mm

The following table of minimum cupboard dimensions only allow the minimum space required for the appliance (including the F & E cistern and optional expansion vessel) and any extra space required for shelving etc in the case of airing cupboards etc must be added.

**NOTE:** The sealed heating system expansion vessel is not supplied with the standard unit but is available at extra cost as part of an optional primary expansion kit and has been shown for information only.

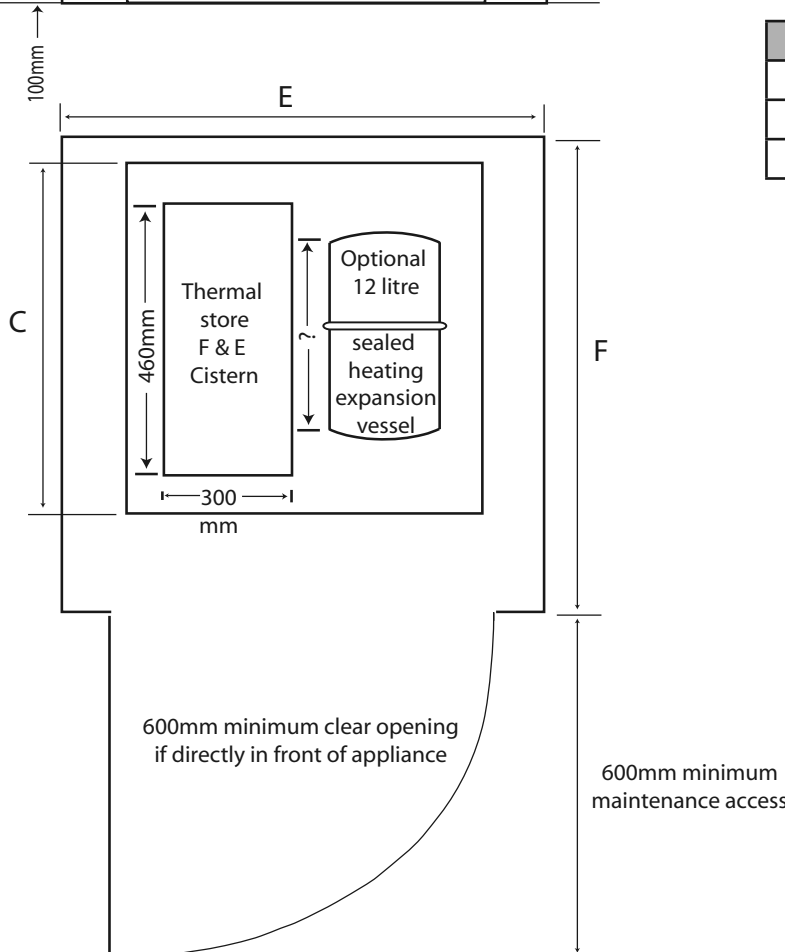

MINIMUM CUPBOARD DIMENSIONS			
	Height	Width	Depth
Model	D	E	F
Both	2200mm*	650mm	650mm

**Note:** The above cupboard height assumes the use of the installation pallet, the F & E cistern and optional expansion vessel.

\* Please note: If a ballvalve and overflow are fitted the clearance above the F & E cistern will need to increase to 350mm to meet the minimum requirements of the Water Regulations and the minimum cupboard height will need to increase to 2300mm.

# 1.0 DESIGN

## 1.2 TECHNICAL DATA

It is easier if all pipes terminate vertically in the positions shown below. Compression or push fit connections are recommended. All pipe positions are approximate and subject to a tolerance of  $\pm 10\text{mm}$  in any direction.

**Note:** The appliance is designed so that the heating flow and return and the domestic hot and cold water pipework run from below into the appliance.

The thermal store cold feed/open vent and central heating expansion vessel AAV connections are on the top of the appliance along with the electrical cable entries.

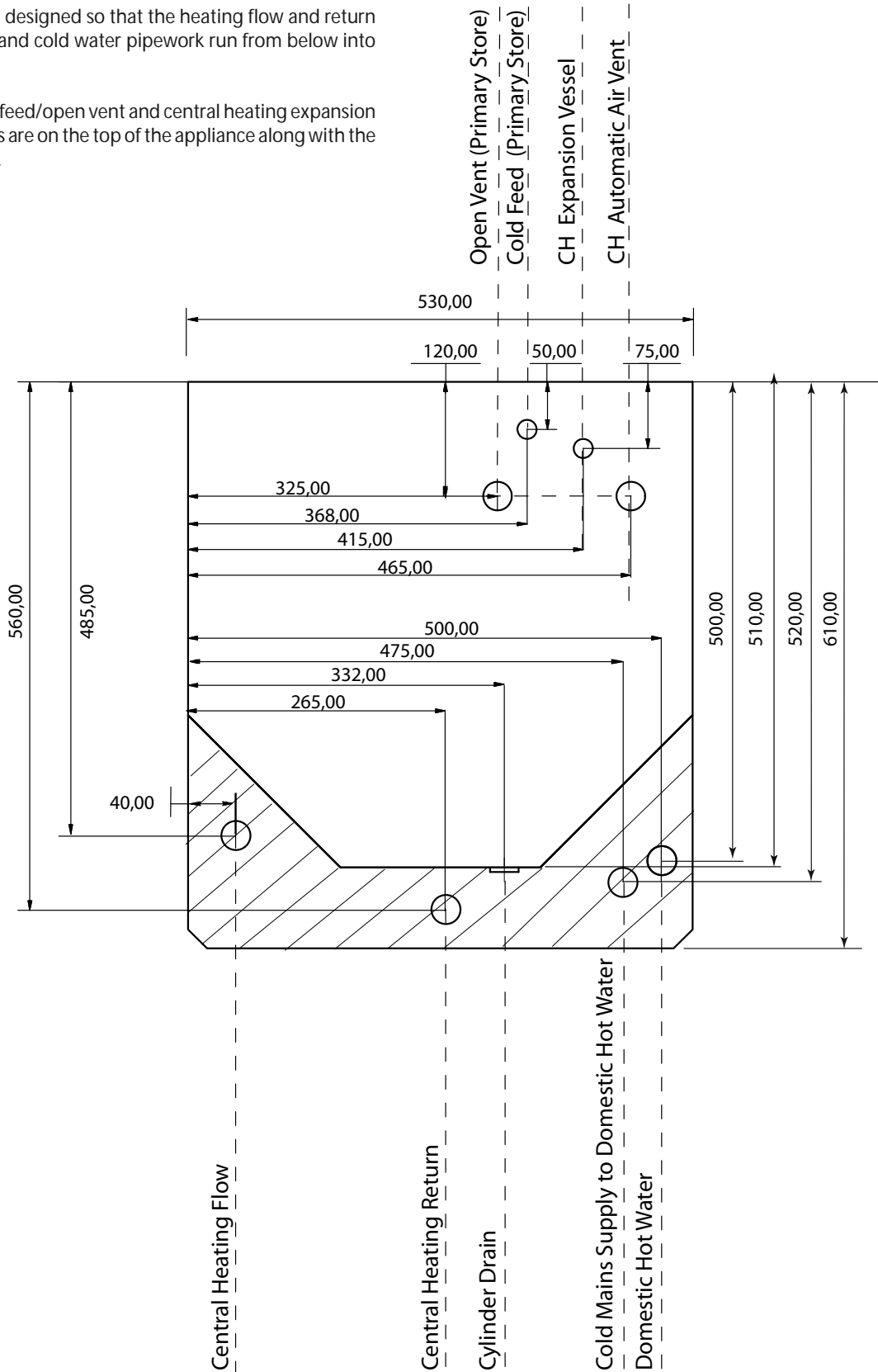

## 1.3 SYSTEM DETAILS

Typical Electrical Connection Arrangement

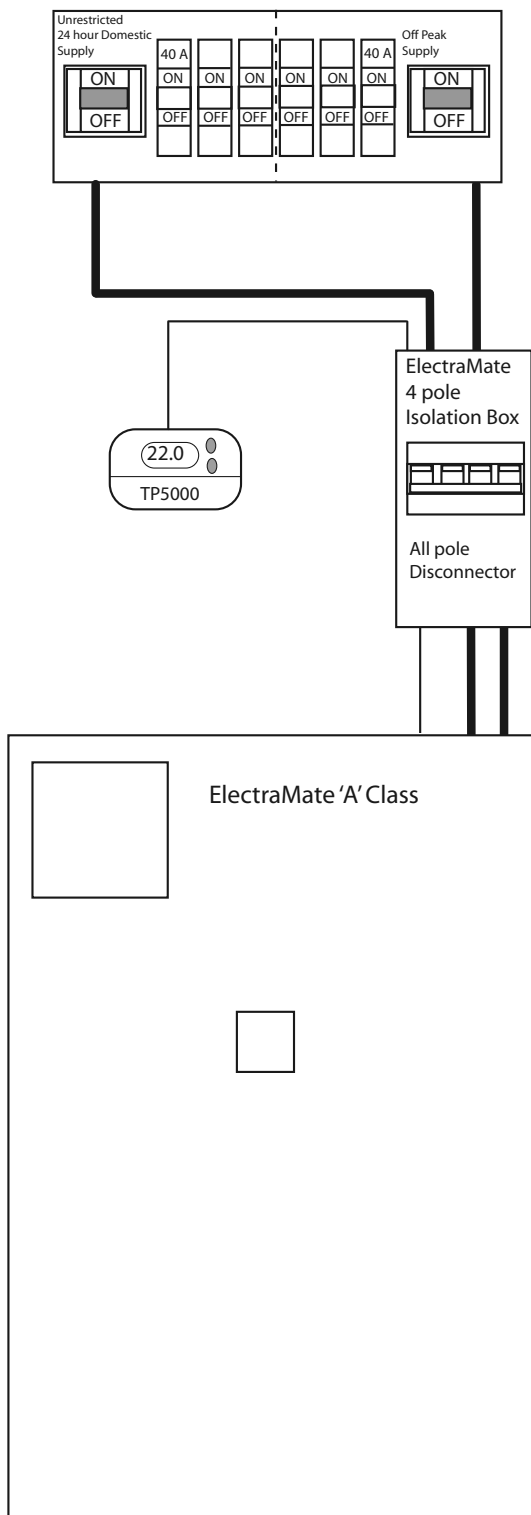

The standard E10 appliance requires 2 electrical supplies, a 24 hour ON PEAK continuous unrestricted supply and an OFF PEAK restricted supply. The Multi Tariff model has been designed specifically to work with restricted tariffs but will work with all currently available tariffs/supplies. In each case 2 supplies will be required rated at 40 amps for the EMA 225/9 and 32 amps for the EMA 225/6 model. A schematic arrangement of the supply connections for both models is shown opposite. The unit is shipped with a programmable room thermostat (TP 5000), a 4 core 0.75mm<sup>2</sup> cable is also required to connect this device.

To ensure efficient operation of the appliance it is important that discussions take place with the Electrical Supply Authority to ensure that the best off peak supply/tariff is utilized.

When designing the electrical system reference should be made to the latest issue of the IEE Requirements for Electrical Installations and the table on the next page to ensure that the electrical supplies are adequate and that the correct circuit protection/cable sizes are chosen.

This is particularly important in existing properties, especially if these are blocks of flats/apartments.

However, the ACB will only allow the supply to each of the two elements in the electric boiler/heaters to be switched at random to keep the maximum simultaneous switching current to a minimum. The random switching will vary at each cycle and for each appliance.

This soft start will minimise network simultaneous loading and help the supply utility reduce transformer and switch gear provision.

**Note: The 4 pole isolation box shown is available as an optional extra.**

## ElectraMate A-Class Wiring Guide

**Note:** The drawing shows the arrangement for the 9kw appliance see table below for 6kw model.

1. This appliance needs two 40 amp supplies. The unit will only ever draw 9 kW heater load on one supply and never both. The control system is electrically inter-locked to prevent this from happening.
2. The 24 hour unrestricted supply feeds the control circuit at all times and the 9kw heater load during both OFF-PEAK & ON-PEAK periods, the teleswitch internally switches over during off-peak periods.
3. The Restricted OFF-PEAK supply only ever feeds the signal input and its own control relay at times dictated by the supply company and the tariff selected.
4. We recommend you select from the locally available tariffs the one that gives you the greatest number of true OFF-PEAK hours of operation, spread evenly across any 24 hour period particularly around peak demand times of the day. We Believe the best all round SAP approved tariff is the (Economy 10 Unrestricted).

Gledhill optional extra: Local isolator box, with a 4 pole linked disconnector, room thermostat installer terminals and din rail earth connections pre-assembled. Clearly labelled giving a single point of isolation for maintenance work.

### 1.3 SYSTEM DETAILS

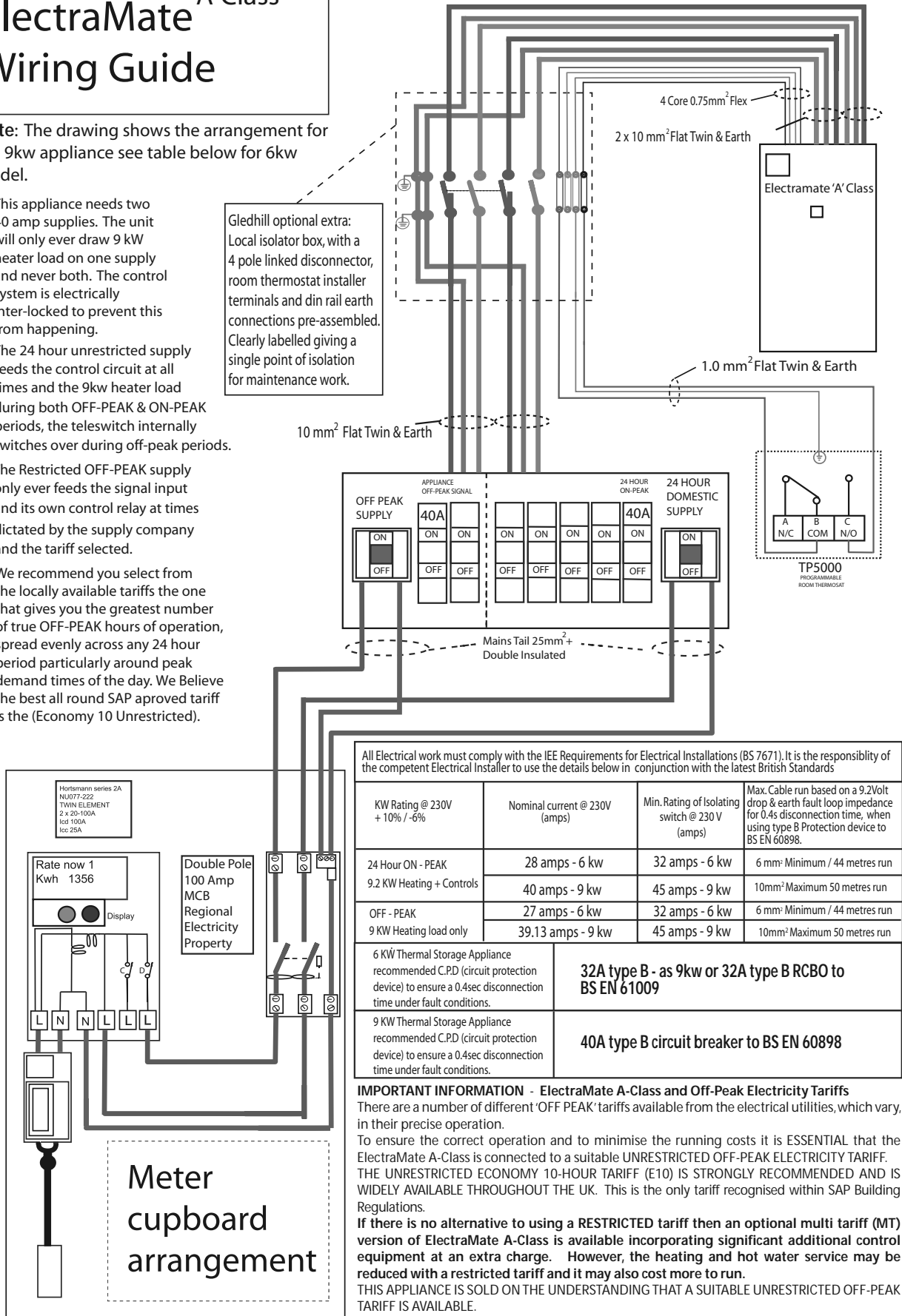

All Electrical work must comply with the IEE Requirements for Electrical Installations (BS 7671). It is the responsibility of the competent Electrical Installer to use the details below in conjunction with the latest British Standards

KW Rating @ 230V +10% / -6%	Nominal current @ 230V (amps)	Min. Rating of Isolating switch @ 230 V (amps)	Max. Cable run based on a 9.2Volt drop & earth fault loop impedance for 0.4s disconnection time, when using type B Protection device to BS EN 60898.
24 Hour ON - PEAK 9.2 KW Heating + Controls	28 amps - 6 kw 40 amps - 9 kw	32 amps - 6 kw 45 amps - 9 kw	6mm² Minimum / 44 metres run 10mm² Maximum 50 metres run
OFF - PEAK 9 KW Heating load only	27 amps - 6 kw 39.13 amps - 9 kw	32 amps - 6 kw 45 amps - 9 kw	6mm² Minimum / 44 metres run 10mm² Maximum 50 metres run

6 kW Thermal Storage Appliance recommended C.P.D (circuit protection device) to ensure a 0.4sec disconnection time under fault conditions.	<b>32A type B - as 9kw or 32A type B RCBO to BS EN 61009</b>
9 KW Thermal Storage Appliance recommended C.P.D (circuit protection device) to ensure a 0.4sec disconnection time under fault conditions.	<b>40A type B circuit breaker to BS EN 60898</b>

**IMPORTANT INFORMATION - ElectraMate A-Class and Off-Peak Electricity Tariffs**  
 There are a number of different 'OFF PEAK' tariffs available from the electrical utilities, which vary, in their precise operation.  
 To ensure the correct operation and to minimise the running costs it is ESSENTIAL that the ElectraMate A-Class is connected to a suitable UNRESTRICTED OFF-PEAK ELECTRICITY TARIFF. THE UNRESTRICTED ECONOMY 10-HOUR TARIFF (E10) IS STRONGLY RECOMMENDED AND IS WIDELY AVAILABLE THROUGHOUT THE UK. This is the only tariff recognised within SAP Building Regulations.  
**If there is no alternative to using a RESTRICTED tariff then an optional multi tariff (MT) version of ElectraMate A-Class is available incorporating significant additional control equipment at an extra charge. However, the heating and hot water service may be reduced with a restricted tariff and it may also cost more to run.**  
 THIS APPLIANCE IS SOLD ON THE UNDERSTANDING THAT A SUITABLE UNRESTRICTED OFF-PEAK TARIFF IS AVAILABLE.  
 Please contact your electricity provider to determine which off-peak tariff is available. If there are any queries then please contact our TECHNICAL HELPLINE on 08449 310000.

# 1.0 DESIGN

## Hot and Cold Water System

### General

A schematic layout of the hot and cold water services in a typical small dwelling is shown below. ElectraMate A-Class will operate at mains pressures as low as 2.0 bar and as high as 5 bar although the recommended range is 2-3 bar. All pressures must be achievable when the local demand is at its maximum and be measured at the connection to the appliance. It is also important to check that all other equipment and components in the hot and cold water system are capable of accepting the mains pressure available to the property. If the mains pressure can rise above 5 bar or the maximum working pressure of any item of equipment or component to be fitted in the system, a pressure limiting (reducing) valve set to 3 bar will be required.

No check valve or similar device should be fitted on the cold water supply branch to the ElectraMate A-Class.

The hot water flow rate from the ElectraMate A-Class is directly related to the adequacy of the cold water supply to the dwelling. This must be capable of providing for those services, which could be required to be supplied simultaneously, and this maximum demand should be calculated using procedures defined in BS 6700.

If a water meter is fitted in the service pipe, it should have a nominal rating to match the maximum hot and cold water peak demands calculated above in accordance with BS 6700. This could be up to 50ltr/min in some properties.

### Use in Hard Water Areas

The patented control system offers a sophisticated level of pump speed control and will help prevent the formation of scale. This prevents domestic hot water from exceeding 55°C for most of the operational times of the appliance.

## 1.3 SYSTEM DETAILS

The pre-set temperature of approximately 52°C is not adjustable.

The Building Regulations L1A: New dwellings/ L1B: Existing dwellings and the requirements set out in the Domestic Heating Compliance Guide specify that "where the mains water hardness exceeds 200ppm provision should be made to treat the feed water to water heaters and the hot water circuit of combination boilers to reduce the rate of accumulation of lime scale".

To comply with this requirement the hardness of the mains water should be checked by the installer and if necessary the optional factory fitted in-line scale inhibitor should be specified at the time of order for hardness levels between 200 and 300 ppm (mg/l).

Where the water is very hard ie 300ppm (mg/l) and above the optional polyphosphate type, inhibitor should be specified at the time of order. However, this will need to be fitted by the installer at a suitable point in the cold water supply to the appliance.

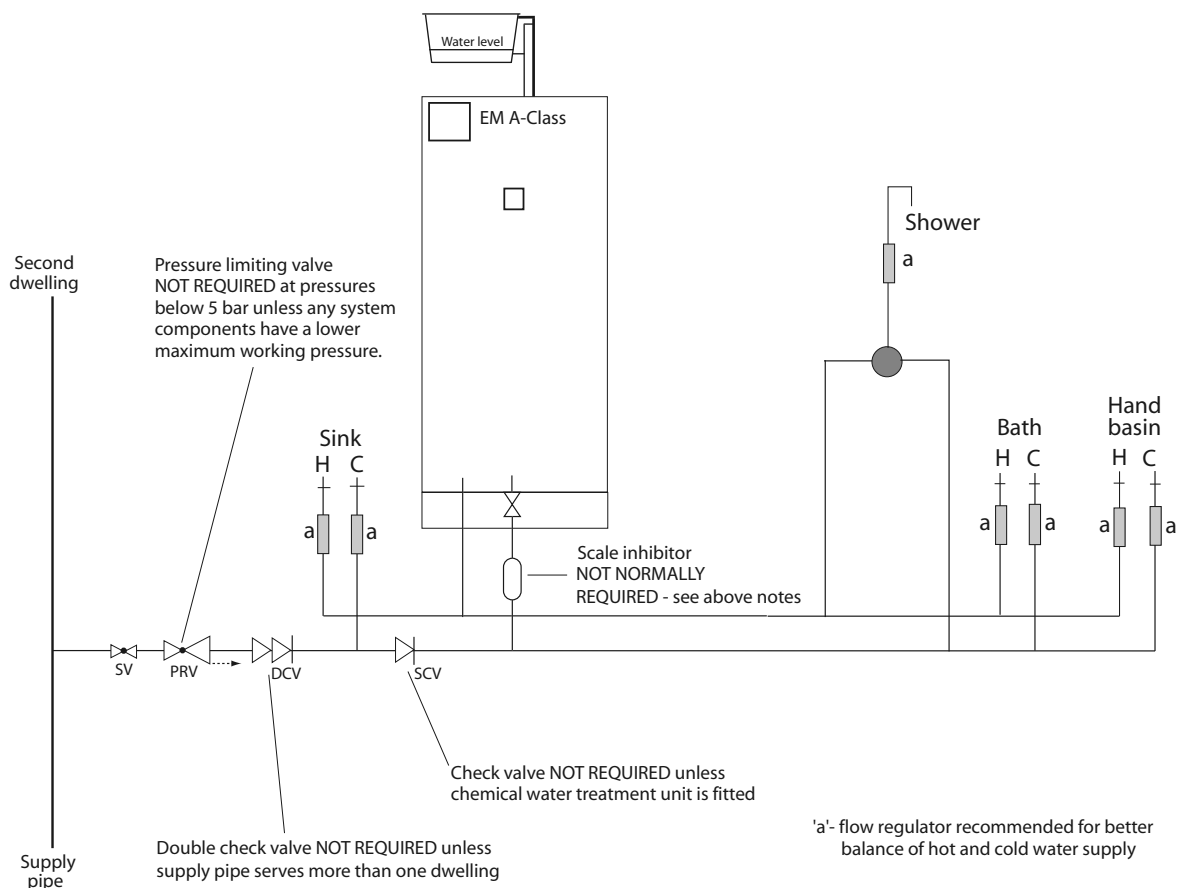

Typical hot and cold water distribution

## 1.3 SYSTEM DETAILS

### Hot and Cold Water System

#### Pipe Sizing / Materials

To achieve even distribution of the available supply of hot and cold water, it is important in any mains pressure system, that the piping in a dwelling should be sized in accordance with BS 6700.

However, the following rule of thumb guide lines should be adequate for most smaller property types as long as water pressures are within the recommended range of 2-3 bar.

1. A 15mm copper or equivalent external service may be sufficient for a small 1bathroom dwelling (depending upon the flow rate available), but the minimum recommended size for new dwellings is 22mm (25mm MDPE).
2. The internal cold feed from the main incoming stop tap to the ElectraMate should be run in 22mm pipe. The cold main and hot draw-off should also be run in 22mm as far as the branch to the bath tap.
3. The final branches to the hand basins and sinks should be in 10mm and to the baths and showers in 15mm. (1 metre minimum)
4. **We would recommend that best results for a balanced system are achieved by fitting appropriate flow regulators to each hot and cold outlet. This is particularly relevant where the water pressures are above the recommended water pressure range of 2-3 bar. (See Appendix 1 for further details.**

**Note: If manifolds (available as an optional extra) are being used suitable flow regulators are automatically provided in the manifold and do not need to be provided at each outlet - See Appendix B for further details.**

All the recommendations with regard to pipework systems in this manual are generally based on the use of BS/EN Standard copper pipework and fittings.

However, we are happy that plastic pipework systems can be used in place of copper internally as long as the chosen system is recommended for use on domestic hot and cold water systems by the manufacturer and is installed fully in accordance with their recommendations.

It is also essential that if an alternative pipework material/system is chosen the manufacturer confirms that the design criteria of the new system is at least equivalent to the use of BS/EN Standard copper pipework and fittings.

#### Taps/Shower Fittings

Aerated taps are recommended to prevent splashing.

**Any type of shower mixing valve can be used as long as both the hot and cold supplies are mains fed. However, all mains pressure systems are subject to dynamic changes particularly when other hot and cold taps/showers are opened and closed, which will cause changes in the water temperature at mixed water outlets such as showers. For this reason and because these are now no more expensive than a manual shower we only recommend the use of thermostatic showers with this appliance, even if these are the over the bath/telephone handset type.**

**The shower head provided must also be suitable for mains pressure supplies.**

The hot water supply to a shower-mixing valve should be fed wherever practical directly from the ElectraMate A-Class or be the first draw-off point on the hot circuit. The cold supply to a shower-mixing valve should wherever practical be fed directly from the rising mains via an independent branch. The shower must incorporate or be fitted with the necessary check valves to provide back-syphonage protection in accordance with the Water Regulations.

The supply of hot and cold mains water directly to a bidet is permitted provided that it is of the over-rim flushing type and that a type 'A' air gap is incorporated.

#### Hot and Cold Water System

If the length of the hot water draw off pipework is excessive and the delivery time will be more than 1 minute before hot water is available at the tap, you may wish to consider using trace heating to the hot water pipework such as the Raychem HWAT system. Please consult Gledhill Technical Department for further details.

Please note that the ElectraMate A-Class is NOT suitable for use with a secondary domestic hot water circulation system.

It is important that the cold water pipework is adequately separated/protected from any heating/hot water pipework to ensure that the water remains cold and of drinking water quality.

## 1.3 SYSTEM DETAILS

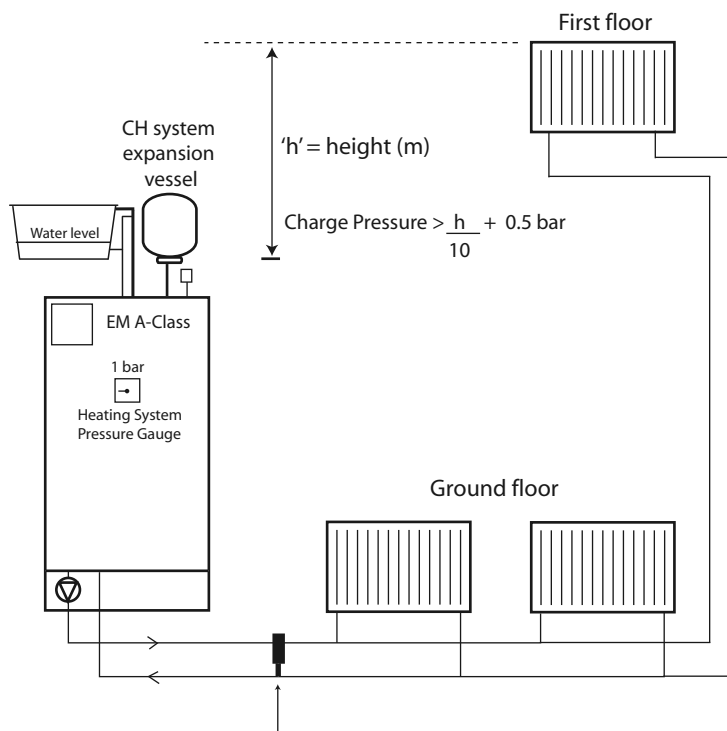

Full bore auto bypass valve NOT REQUIRED unless the heating system incorporates mechanical thermostatic control valves e.g. T.R.V's to all radiators or 2 port zone valves. As an alternative one of the radiators can be fitted with lockshield valves which are left fully open, permanently.

### Heating System

#### General

A schematic layout of an ElectraMate used in a standard sealed central heating system for a typical small dwelling is shown above.

The heating circuit is taken from the connections provided in the ElectraMate A-Class and is piped in the conventional manner.

Because the central heating system is sealed, the pipework can run at a higher level than the appliance if required as long as suitable air vents are provided. Connections for an expansion vessel and automatic air vent are provided on top of the appliance and need to be fitted to the appliance. A feed and expansion cistern will still be required for the ElectraMate itself and is provided without a ballvalve and overflow as standard for manual filling. However, a ballvalve and overflow can be provided by the installer if preferred.

**If any radiators are located above the level of the ElectraMate A-Class the system should be designed so that gravity circulation does not occur when the heating pump is not running. To be certain of preventing this it is recommended that a check valve, or valves, are fitted on the vertical flow pipes.**

The heating circuit operates on the normal primary boiler temperatures of 82°C flow and 71°C return. Therefore any traditional hot water radiators or convectors can be used with this system and it is recommended that they are sized in accordance with BS EN 442.

The Grundfos UPS 15-50 central heating pump is fitted to the appliance as standard. However the appliance can be provided with the option of a modulating pump if required at extra cost if this is specified at the time of order.

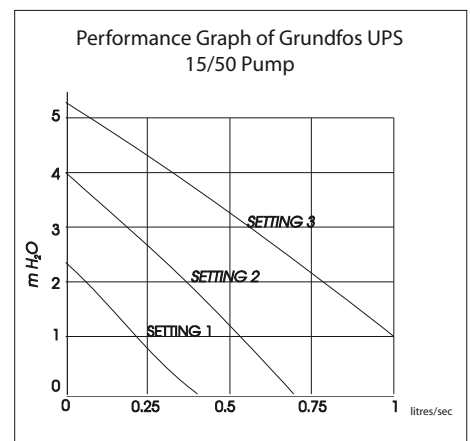

The pump characteristics for the standard UPS 15:50 are shown in the performance graph above.

All the recommendations with regard to pipework systems in this manual are generally based on the use of BS/EN Standard copper pipework and fittings.

However, we are happy that plastic pipework systems can be used in place of copper internally as long as the chosen system is recommended for use on domestic heating systems by the manufacturer and is installed fully in accordance with their recommendations. We always recommend the use of barrier pipe for these systems.

It is also essential that if an alternative pipework material/system is chosen the manufacturer confirms that the design criteria of the new system is at least equivalent to the use of BS/EN Standard copper pipework and fittings.

# 1.0 DESIGN

## 1.3 SYSTEM DETAILS

### Filling the ElectraMate A-Class Appliance/ Central Heating System

The feed and expansion cistern is used to fill the ElectraMate appliance only and the sealed central heating system will need to be provided with a temporary filling loop (Method 1) or permanent CA type backflow prevention device (Method 2) complying fully with the Water Regulations - see below for further details.

The feed and expansion cistern with this model is provided as standard without a ballvalve and overflow for manual filling via a temporary/permanent mains connection protected by a suitable temporary filling loop which must be removed after filling.

However, a ballvalve and overflow can be provided by the installer if preferred.

In both cases the water level should be set to the level shown on the label provided.

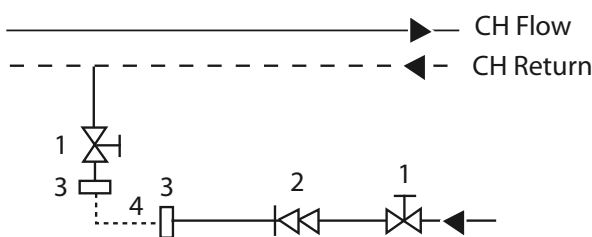

1. Control/isolating valve
2. Double check valve
3. Hose union connectors
4. Temporary hose connection

#### Sealed system filling method 1 (Recommended)

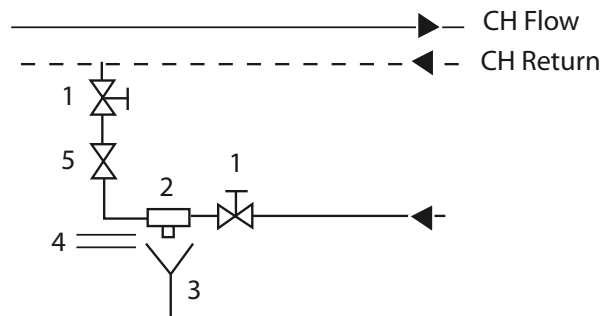

1. Control/isolating valve
2. Type CA Backflow Prevention device
3. Tundish/discharge pipe
4. Air Gap
5. Pressure regulator - set to the system cold fill pressure

#### Sealed system filling method 2

**Note:** The CA device requires a suitable pressure differential (min. 2.0 bar dynamic inlet pressure) and permanent discharge pipe laid to an adequate fall to operate successfully. Both should be considered before choosing this method.



# 1.0 DESIGN

## 1.3 SYSTEM DETAILS

### Expansion vessel requirements

The primary store is open vented. The central heating system is sealed. The size of the expansion vessel supplied with the optional Primary Expansion Kit is considered adequate for a typical installation. However it is the designers/installers responsibility to check this and provide an additional expansion vessel if necessary. The optional expansion vessel is pre-charged to 1.0 bar.

The expansion vessel must be suitable to accommodate the change in volume of the water in the primary system from 10°C to 110°C as specified in BS 5449 : 1990 clause 16.2.

In normal circumstances an initial system charge pressure of 1.0 bar is suitable for most domestic installations.

The minimum system pressure (when cold) should not be less than the static head plus 0.5 bar i.e. the height of the highest point in the system above the expansion vessel plus a safety margin of 0.5 bar. If a different system pressure is required than 1.0 bar the initial system and vessel charge pressures must be adjusted to the same value.

If an additional expansion vessel is required, this must comply with BS 4814 and must be suitable for heating circuit temperatures up to 110°C.

The expansion vessel's must be sized to comply with the sizing procedure outlined in BS 5449 : 1990.

**Note : There must be no isolating valve between the expansion vessel(s) and the appliance or any other such device.**

All Electrical work must comply with the IEE Requirements for Electrical Installations (BS 7671). It is the responsibility of the component Electrical Installer to use the details below in conjunction with the latest British Standards.

EMA 225/6			
kW rating @ 230V + 10% / -6%	Nominal current @ 230VAC	Min. Rating of isolating switch@ 230VAC (32 amp)	Max cable run based on a 9.2 volt drop and earth fault loop impedance for 0.4s disconnection time, when using type B protection device to BS EN 60898.
24 hour ON - PEAK 6.2 kW Heating & Controls	27 amp	32 amp	6mm <sup>2</sup> Maximum 44 mtrs cable run
Restricted OFF - PEAK 6.0 kW heating load only	26 amp	32 amp	6mm <sup>2</sup> Maximum 44mtrs cable run
6.2 kW Thermal Storage Appliance recommended C.P.D.(circuit protection device) to ensure a 0.4 sec disconnection time under fault conditions		32A type B circuit breaker to BS EN 60898 or 32A type B RCBO to BS EN 61009	

## 2.1 SITE REQUIREMENTS

The appliance is designed to be installed in an airing/cylinder cupboard and the relevant minimum dimensions are provided in section 1.2 Technical Data.

Because of the ease of installation we recommend that the cupboard construction is completed and painted before installation of the appliance. The cupboard door can be fitted after installation.

If the unit needs to be stored prior to installation it should be stored upright in a dry environment and on a level base/floor.

Installation and maintenance access is needed to the front of the appliance and the separate feed and expansion cistern and primary expansion vessel if fitted in the cupboard. See Technical Data section for further details.

The minimum dimensions contained in section 1.2 Technical Data allow for the passage/connection of pipes to the appliance from any direction as long as the appliance is installed on the installation pallet. Extra space may be needed if the installation pallet is not used.

The floor of the cupboard needs to be level and even and capable of supporting the weight of the appliance when full. If the ElectraMate A-Class is located on a platform above the floor this must provide continuous support to the whole base area and be made of a material which will not deteriorate if exposed to moisture as required by the relevant NHBC Standards. Details of the weight when full is provided in section 1.2 Technical Data.

The appliance is designed to operate as quietly as practicable. However, some noise (from pumps etc) is inevitable in any heating system. This will be most noticeable in cupboards formed on bulkheads, or at the mid span of a suspended floor. In these cases the situation can be improved by placing the appliance on a suitable sound deadening material (i.e. carpet underlay or similar).

Cupboard temperatures will normally be higher than in a conventional system and the design of the cupboard and door will need to take this into account. Normally ventilation is not required but it is good practice to help reduce the cupboard ambient temperature where ever possible.

A suitable location will be needed for the separate feed and expansion cistern and primary expansion vessel. This will often be at high level in the cupboard housing the ElectraMate A-Class but can be at a remote position if required. The dimensions and clearances are provided in section 1.2 Technical Data. The location will need to provide a suitable route for the cold feed/expansion and cold mains supply/overflow

pipes to the feed and expansion cistern as well as the expansion pipe from the vessel to the appliance.

The electrical supplies must be correctly earthed, polarized and installed in accordance with the latest edition of the IEE requirements for electrical installations BS 7671: 2001.

The electrical mains supply needs to be 230V/50Hz.

The standard (E10) appliance requires a 24 hour on peak continuous supply and an off peak restricted supply.

The multi tariff model has been designed specifically to work with all restricted tariffs but will work with any currently available tariffs/supplies.

In each case 2 supplies will be required each rated at 32 amps for the EMA 225/6 and 45 amps for the EMA 225/9.

A means for disconnection from the supply mains having a contact separation in all poles that provides full disconnection under over voltage category III conditions must be incorporated in the fixed wiring in accordance with the wiring rules. This should be located within 1m of the appliance. The supplies must only serve the appliance. Alternatively two separate isolators could be used, but clear labelling must be displayed identifying dual supplies feed this appliance.

The minimum breaking capacity of the main isolation switch and cable sizes/lengths at 230V shall follow the recommendations in the tables below.

All Electrical work must comply with the IEE Requirements for Electrical Installations (BS 7671). It is the responsibility of the component Electrical Installer to use the details below in conjunction with the latest British Standards.

### EMA 225/9

Kw rating @ 230V + 10% / -6%	Nominal current @ 230VAC	Min. Rating of isolating switch @ 230VAC	Max cable run based on a 9.2 volt drop and earth fault loop impedance for 0.4s disconnection time, when using type B protection device to BS EN 60898.
24 hour ON - PEAK 9.2 kW Heating & Controls	40.0 Amps	45 amp	10mm <sup>2</sup> Maximum 50 mtrs cable run
Restricted OFF - PEAK 9.0 kW heating load only	39.2 Amps	45 amp	10mm <sup>2</sup> Maximum 50 mtrs cable run
9.2 kW Thermal Storage Appliance recommended C.P.D.(circuit protection device) to ensure a 0.4 sec disconnection time under fault conditions	45A type B circuit breaker to BS EN 60898		

## 2.2 INSTALLATION

### Preparation/placing the appliance in position.

Details of the recommended positions for termination of the first fix pipework are provided in section 1.2 Technical Data. The pipework can be located or its position checked using the template provided with each appliance. If these have been followed installation is very simple and much quicker than any other system.

The appliance is supplied shrink wrapped and carrying handles are provided in the back of the casing.

The feed and expansion cistern/expansion vessel complete with any interconnecting pipework are provided in a separate box. If flexible connections have been ordered these will be supplied in the same box as the feed and expansion cistern. If ordered the optional/primary expansion kit will be supplied in a separate box.

The appliance should be handled carefully to avoid damage and the recommended method is shown opposite. Whenever it is possible it is recommended that it is moved using a suitable sack type truck on the rear face.

Before installation the site requirements should be checked and confirmed as acceptable. The bottom part of the plastic cover /protective wrapping should be removed and the appliance placed in position.

Remove the front panel by removing the two retaining screws and lifting the front panel up and out to clear the door bottom locating pins. Ensure the panel is replaced on completion and the retaining screws are replaced to secure the front panel back in position.

**Note:** Although the above guidance is provided any manual handling/lifting operations will need to comply with the requirements of the Manual Handling Operations Regulations issued by the H.S.E.

The appliance can be moved using a sack truck on the rear face although care should be taken and the route should be even.

In apartment buildings containing a number of storeys we would recommend that the appliances are moved vertically in a mechanical lift.

If it is proposed to use a crane expert advice should be obtained regarding the need for slings, lifting beams etc.

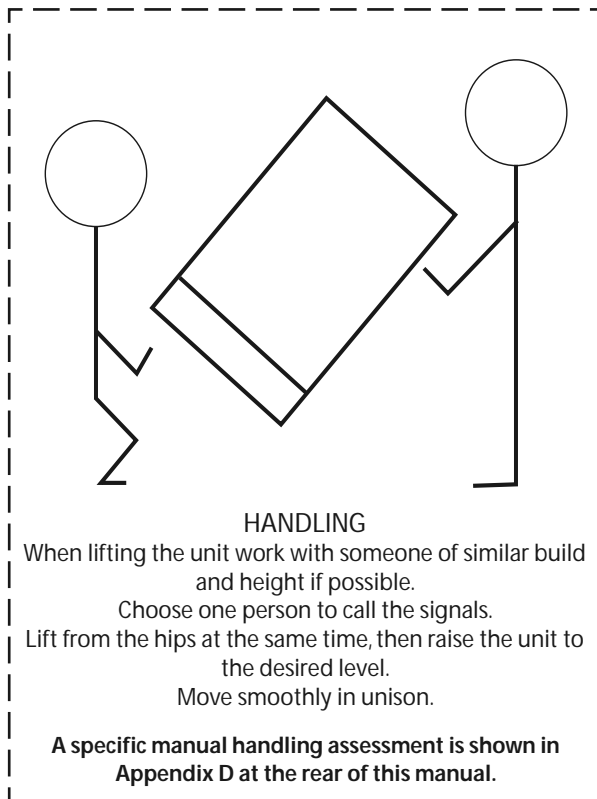

## 2.0 INSTALLATION

### 2.2 INSTALLATION

#### Pipework connections

The position of the pipework connections is shown opposite. The connection sizes are shown below and their positions/dimensions are listed in Section 1.2 Technical Data.

All the connections are also labelled on the appliance. It is essential that the pipework is connected to the correct connection.

The connections should be hard piped but we recommend the use of compression or push fit connectors. If plastic pipework is used this must be adequately supported and clipped immediately adjacent to the connections to the appliance.

*Connections A, B, C, D, E and G are plain ended 22mm copper pipe.*

*Connection F and H are plain ended 15mm copper pipe.*

*Drain R $\frac{1}{2}$ " boss*

- A - Domestic Hot Water
- B - Central Heating Flow
- C - Incoming Mains Cold Water
- D - Central Heating Return
- E - Thermal Store Open Vent
- F - Thermal Store Cold Feed
- G - Primary/CH-AAV
- H - Primary/CH-Expansion
- I - Drain Valve **NOT provided with the appliance).**

All factory made joints should be checked after installation in case they have been loosened during transit.

A C.H. expansion vessel should be connected to connection 'H' on top of the appliance.

**There must be no isolating valve between the expansion vessel(s) and the appliance.**

An automatic air vent should be fitted to the C.H. connection 'G' on the top of the appliance.

The thermal store cold feed and open vent must be run from the connections on top of the appliance to the feed and expansion cistern, using the prefabricated pipe work supplied, this will ensure any air can vent during the filling procedure. Do not alter or connect any pressure-relief device to the vent pipe of this water heater.

The appliance should only be filled slowly to prevent any air becoming trapped.



ElectraMate 6kW

# 2.0 INSTALLATION

## 2.2 INSTALLATION

ElectraMate A-Class Un-restricted Economy 10 - 9kW	
Drawn by: Stephen McGachie	Date: 20/04/2007
Checked by: Sandy Gataora	Date: 20/04/2007
Issue No: 3	Signed: .....

B	Blue
Br	Brown
G	Green
Y	Yellow
Gr	Grey
O	Orange
Bl	Black
R	Red

Factory supplied bridge links, not inserted, installer must fit during system commissioning & functional test.

Installer must not use this terminal

**ON PEAK SUPPLY 24 HOURS UN-RESTRICTED**

**OFF PEAK SUPPLY 10 HOURS RESTRICTED**

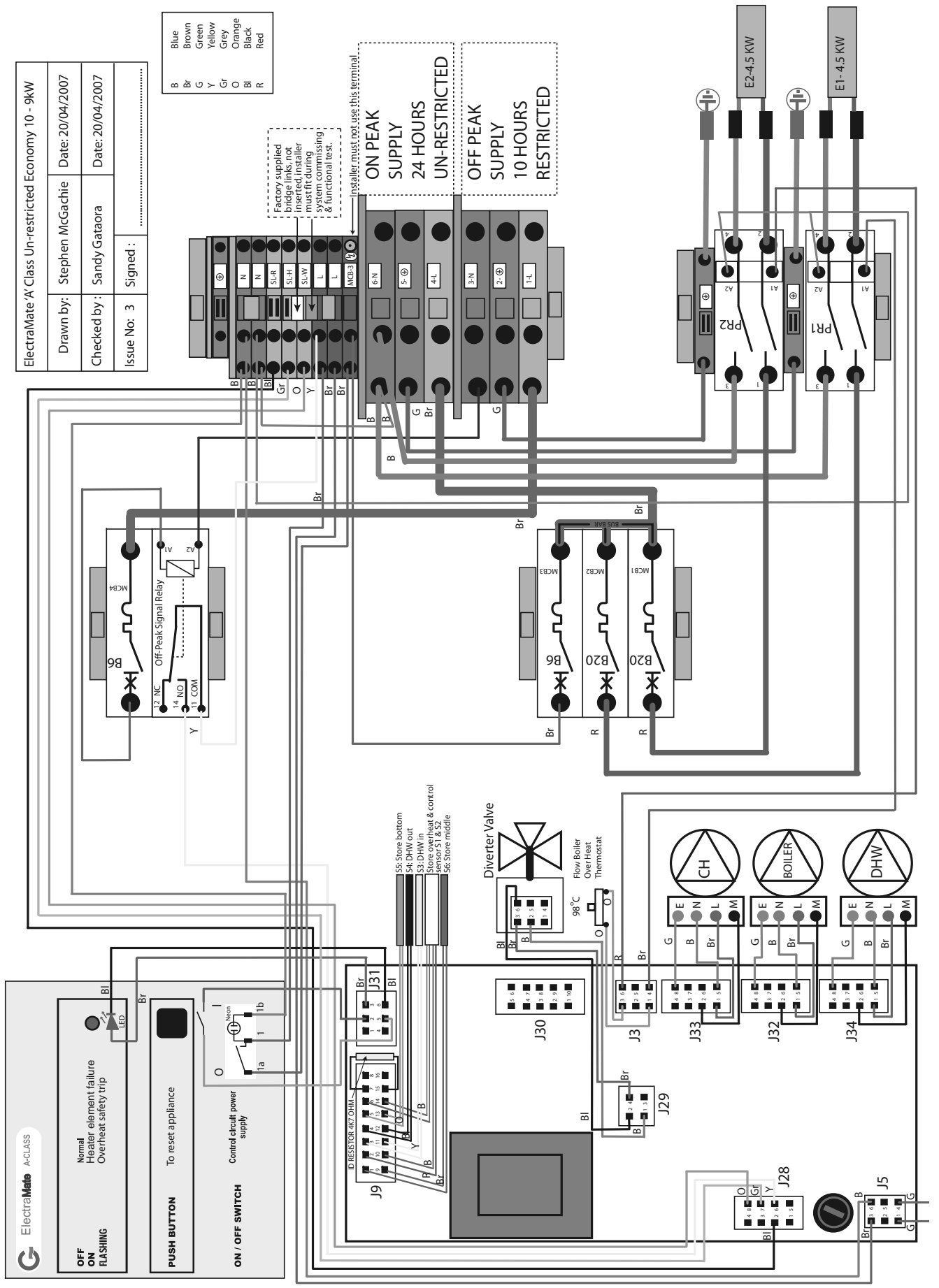

**ElectraMate A-CLASS**

**OFF ON FLASHING**

Normal  
Heater element failure  
Overheat safety trip

**PUSH BUTTON**

To reset appliance

**ON / OFF SWITCH**

Control circuit power supply

# 2.0 INSTALLATION

## 2.2 INSTALLATION

Electramate 'A' Class Un-restricted Economy 10 - 6 kW	
Drawn by: Stephen McGachie	Date: 29/06/2007
Checked by: Sandy Gataora	Date: 29/06/2007
Issue No: 4	Signed: .....

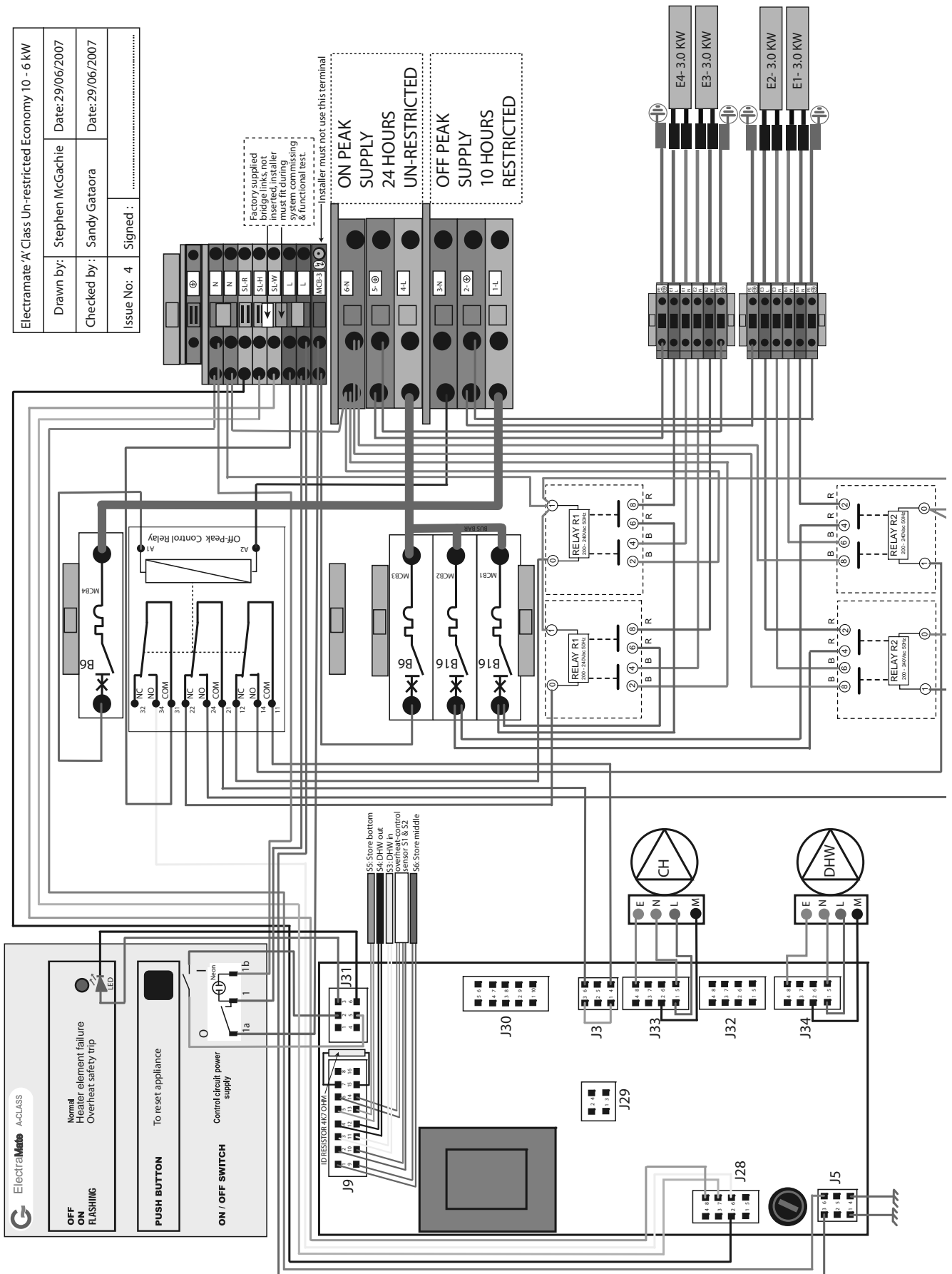

# 2.0 INSTALLATION

## 2.2 INSTALLATION

ElectraMate A Class Multi Tariff - 9kW Model
Drawn by: Stephen McGachie
Date: 30/10/2006
Checked by: Sandy Gataora
Date: 07/11/2006
<b>Issue No: 1</b>
Signed: .....

Blue	B
Brown	Br
Green	G
Yellow	Y
Grey	Gr
Orange	O
Black	Bl
Red	R

Factory supplied bridge links not inserted, installer must fit during system commissioning & functional test.

**ON PEAK SUPPLY 24 HOURS UN-RESTRICTED**

**OFF PEAK SUPPLY 10 HOURS RESTRICTED**

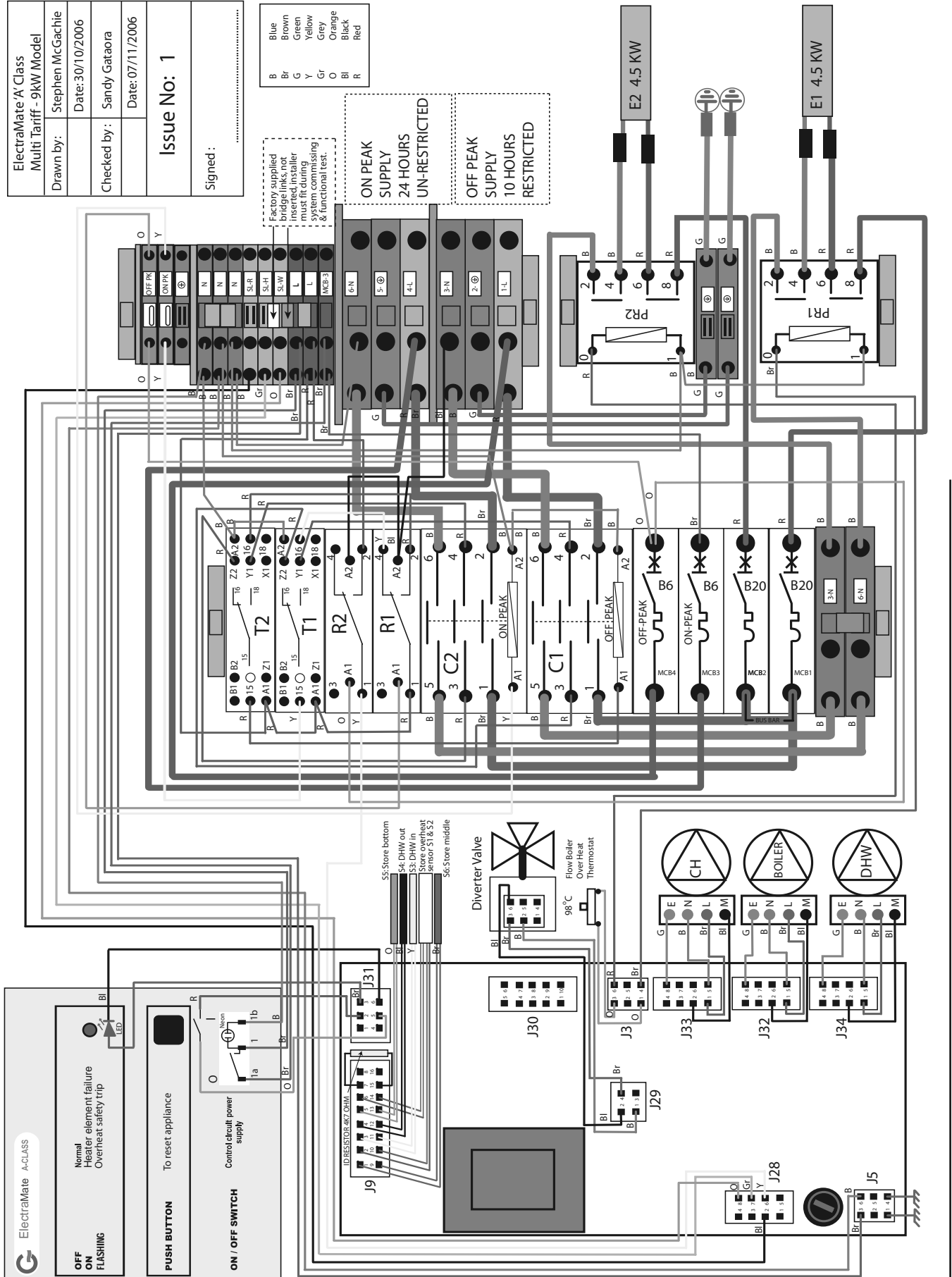

# 2.0 INSTALLATION

## 2.2 INSTALLATION

ElectraMate A Class Multi Tariff - 6kW Model
Drawn by: Stephen McGachie
Date: 07/11/2006
Checked by: Sandy Gataora
Date: 07/11/2006
Issue No: 1
Signed: .....

Blue	B
Brown	Br
Green	G
Yellow	Y
Grey	Gr
Orange	O
Black	Bl
Red	R

Factory supplied bridge links not inserted, installer must fit during system commissioning & functional test.

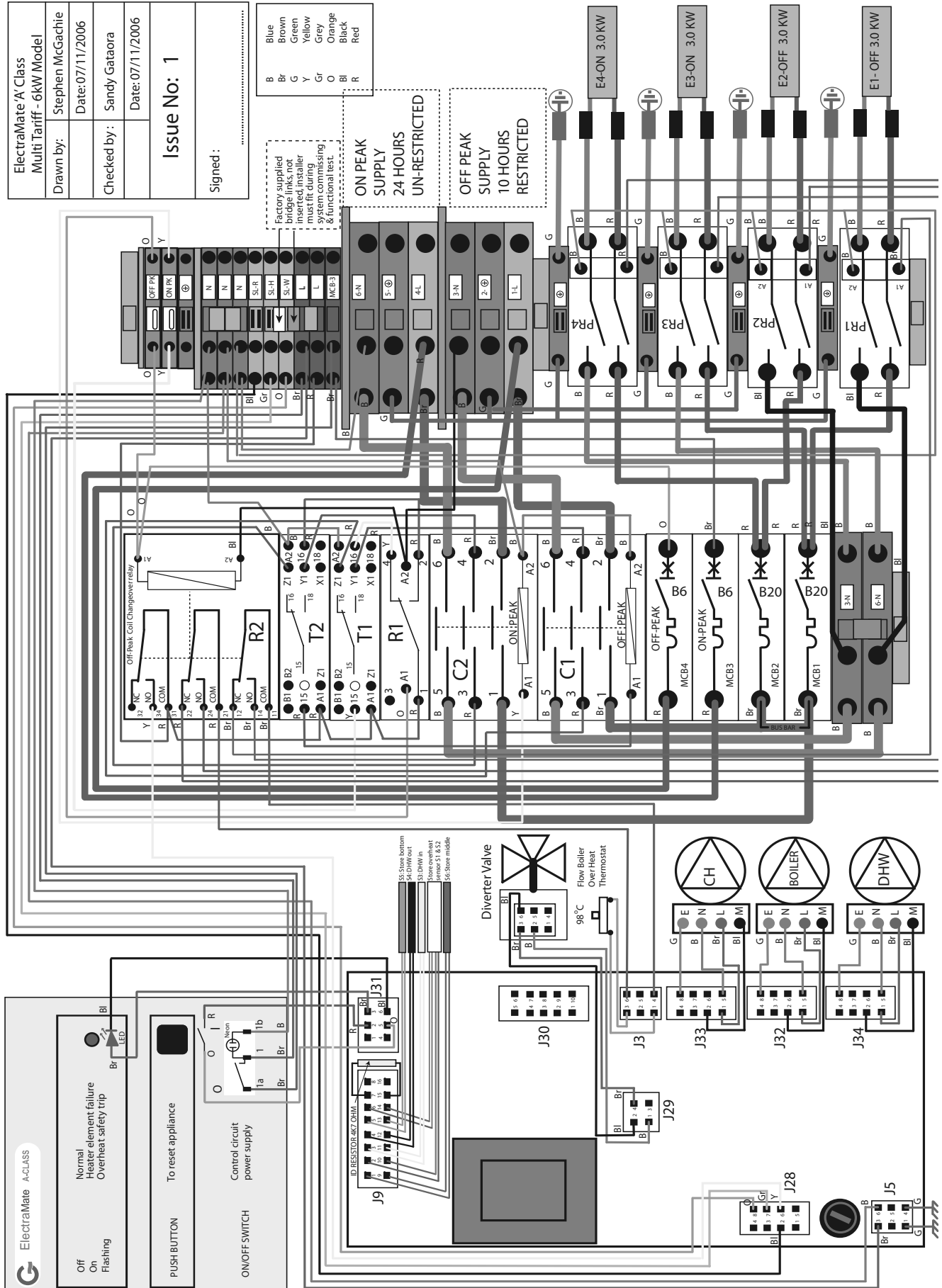



## 2.0 INSTALLATION

### 2.2 INSTALLATION

#### Wiring the System

A printed circuit board (ACB) controls the complete system and all the internal components are prewired to this board, as shown on the Appliance Wiring Diagram on the previous page.

The details of the arrangement and requirements for the external wiring are shown opposite and covered in more detail on the Wiring Guide Diagram in section 1.3 System details and section 2.1 Site Requirements. Check the supplies comply with their requirements.

As shown opposite, two heavy duty electrical supplies are required for the Electramate 'A' Class and therefore a **qualified electrician** must carry out this work. The electrical installation must comply with the IEE requirements for electrical installations (BS 7671) and the requirements of Local Electricity Supply Company. All the terminals are suitably labelled.

**Note:** Do not attempt the electrical work unless you are competent to carry out to the above standards.

Connections to the electrical supplies must allow complete electrical isolation by installing a suitable isolator(s). All poles must be isolated and a single 4 pole isolator is recommended. Alternatively two separate two pole isolators could be used but clear labels must be fixed to inform that a dual supply is fitted and both isolators must be isolated when carrying out any maintenance work.

The isolators must only serve the ElectraMate 'A' Class complete space heating and hot water system together with its controls.

The use of type 'B' circuit breakers to BS EN 60898 are recommended.

Before commencing the wiring, ensure that the power source to which the appliance is to be connected is isolated and checked with an approved and certified tester.

#### **Electrical Connections to the Appliance:**

*Remove the two M5 fixing screws from the top of the unit, pull the cover backward and upwards to clear the bottom locating pins, move the front door clear of the appliance.*

*Insert the two 6mm<sup>2</sup>/10mm<sup>2</sup> feed cables through the large cable gland on the top front right corner, ensure a suitable cable length is pulled through to allow a neat radius on the cable ends, this will ensure the wires when fitted do not pull on the supply connection terminals.*

*Now insert a 4 core 0.75mm<sup>2</sup> cable into the smaller cable gland and connect to the correct terminals as shown on the image opposite.*

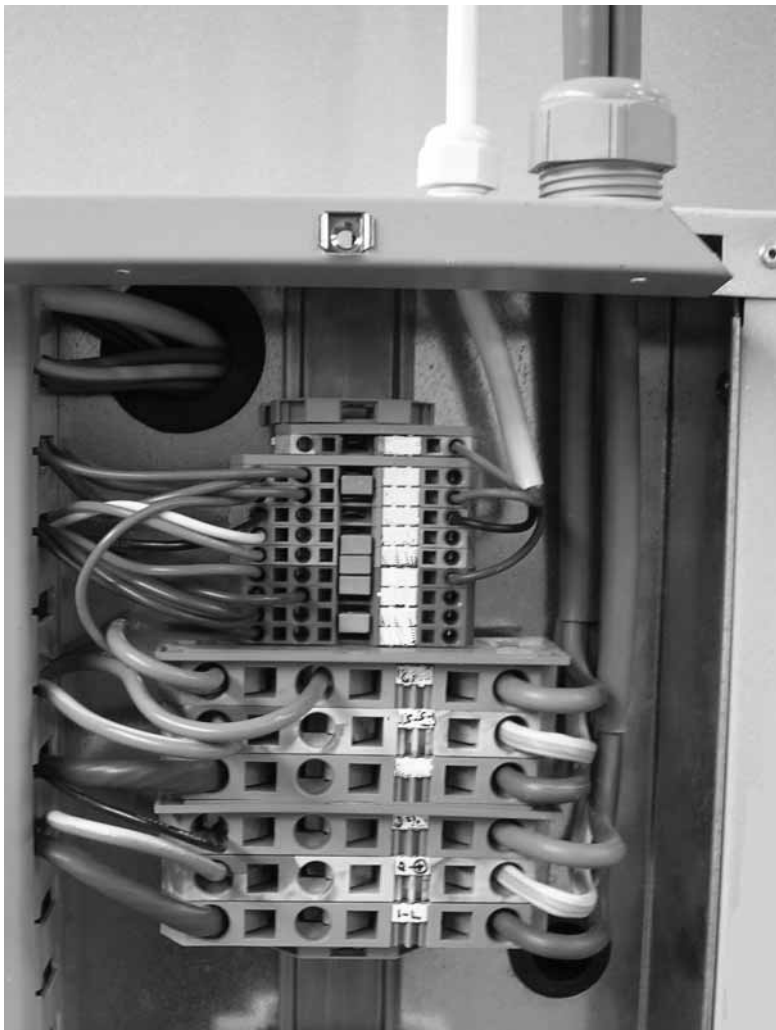

# 2.0 INSTALLATION

## 2.2 INSTALLATION

### Wiring the system (continued.)

Before switching on the electrical supply check all the factory made terminal connections to ensure they have not become loose during transit.

**WARNING - When the wiring is complete but before switching on the appliance electrically ensure the unit is full of water by checking the water level in the feed and expansion cistern. Failure to do this will damage components in the Appliance and their replacement will not be covered by the warranty. Only when you are sure the appliance is full of water should the appliance be switched ON and the operation tested. Replace the front panel when all work is complete.**

**Please note:** The ACB is polarity sensitive therefore if the live and neutral cables are reversed it will not function.

As the standard unit is supplied to suit an unrestricted Economy 10 type tariff the on peak and off peak supply is supplied from the same cable and a separate restricted off peak cable provides the unit an off peak available signal. When the multi tariff model is used with a restricted tariff both supply cables are used at difference times to supply the appliance. For further details regarding this please contact the Gledhill Technical Helpline.

Wiring the Programmable Room Thermostat:

All models are shipped with a Danfoss TP5000 remotely fitted programmable room thermostat, shown opposite.

Fix at a height of approximately 1.5 m from the floor, away from draughts or heat sources such as radiators open fires or direct sunlight.

The normal mounting arrangement is to a standard single gang metal / plastic back box the back plate has standard mounting holes for ease of fixing.

The cable from the ElectraMate 'A' Class will be either 4 core or 3 core in both cases only 2 wires are needed to connect to the TP5000.

Connect the brown wire to the terminal labels 'B COM' and the blue or black wire to the terminal 'C N/O' it is good practice to fit brown sleeving over the return switch wire!

Some existing thermostats will have a neutral and or earth wire connected. These are not required by the TP5000 and must NOT be connected to any TP5000 terminals. Instead the earth wire should be connected to the back box earth post and the neutral should be made electrically safe and coiled in the recess at the back of the TP5000 or wall back box.

At the appliance terminals the brown wire should be connected to a spare permanent live labelled 'L' and the switched return connected to the terminal labelled 'SL-R'; a spare neutral and earth terminal are provided if the installer wishes to use a traditional standard 3 wire and earth room thermostat - see photos on



## 2.3 COMMISSIONING

Open the incoming stop valve and fill the whole of the domestic hot and cold water systems with potable water from the water authority mains supply.

With the standard ElectraMate A-Class the appliance itself will need to be filled manually through the feed and expansion cistern from a temporary supply or from a permanent connection fitted with a suitable temporary filling loop, which must be removed after filling. Once the pressure of the central heating expansion vessel has been checked and if necessary adjusted the central heating system can be filled using the temporary filling loop or CA device method as shown in 1.3 System Details.

During filling of the primary system check and release any air. Then check the ElectraMate A-Class appliance and all the systems for any leaks and repair as necessary.

Before switching on the manual fill standard model check again the level of the water in the feed and expansion cistern and top up if necessary.

It is essential that once filled all systems are commissioned and their operation checked/adjusted to ensure they are performing to their optimum.

It is now a requirement of the Building Regulations that all heating systems are cleansed and inhibited. To achieve this, the primary system should be commissioned by a competent person in accordance with good practice and generally in accordance with the requirements of BS 6798, BS 5449 and BS 7593. Full details of the requirements are given in PAS 33:1999 under section 10 Commissioning. All the relevant commissioning details should be recorded in the Benchmark Log Book.

The central heating pump should be set at a speed at which the temperature difference across the heating circuit close to the ElectraMate A-Class is about 11°C or as specified by the system designers. The pump characteristics are shown in Section 1.2 Technical Data. The plate heat exchanger pump, and the electric boiler pump (9kw model), which are used to generate the domestic hot water are a 4 wire modulating type and are not adjustable.

When using either cleansing or corrosion inhibitor chemical, the manufacturers instructions must always be followed.

### **Cleansing the Primary (Appliance/Central Heating) System**

**When determining the quantity of cleanser required remember that the appliance and central heating system waters are separate and will each require to be dealt with separately.**

### **Cleansing the Hot/Cold Water Systems**

**Fully flush and if necessary chlorinate the hot and cold water system in accordance with the recommendations in the Water regulations and BS 6700.**

### **Primary Water System Treatment**

The radiators and other parts of the circuit will need the application of a scale and corrosion inhibitor such as Fernox MB1.

When determining the quantity of inhibitor required, be sure to remember and allow for the fact that the appliance and central heating water systems are separate - see Section 1.2 Technical Data for volumes.

### **Hot Water Treatment**

It is now a requirement of the Building Regulations that if the hardness level of the mains cold water supply feeding the ElectraMate exceeds 200ppm (mg/l) a suitable inline scale inhibitor should be fitted on the supply. To comply with this the ElectraMate should have been ordered with the Gledhill factory fitted inline scale inhibitor as an optional extra. If this is not the case a separate scale inhibitor will still be required.

## 2.3 COMMISSIONING

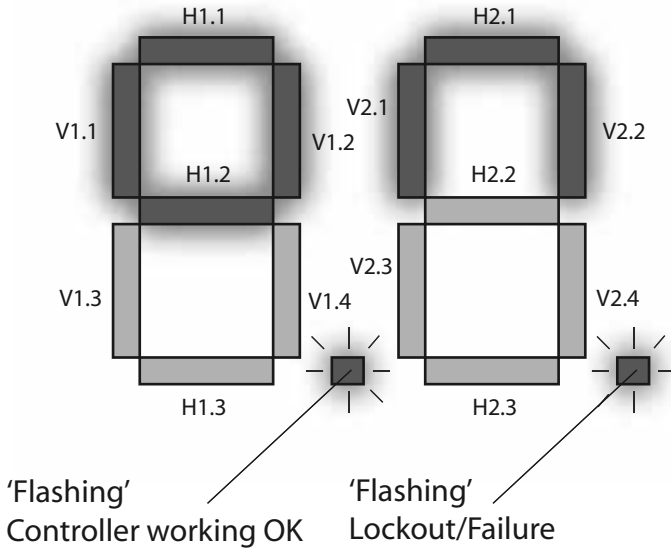

LED	Description
H1.1	Middle store sensor calling for heat
H1.2	Bottom store sensor calling for heat
H1.3	Spare not used
V1.1	HW Programmer calling for heat
V1.3	CH Programmer calling for heat
V1.4	Room thermostat calling for heat
H2.1	PHE pump running
H2.2	CH pump running
H2.3	Flow Boiler pump running (9kw)
V2.1	1st Electric Heater Element On
V2.2	2nd Electric Heater Element On
V2.3	3 Port Diverter Valve ON-PEAK mode (9kW)
V2.4	3 Port Diverter valve OFF-PEAK mode (9kW)

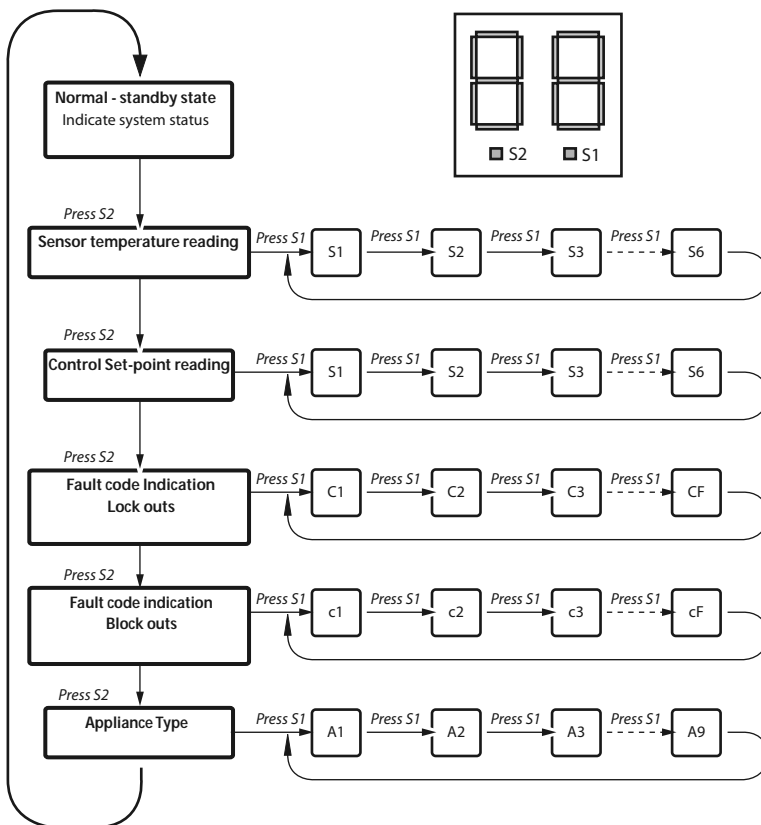

### Appliance Control Board

The appliance control board has a 2 digit display and 2 push buttons which are used to check the status of the appliance, check and set its identity and interrogate it for any current faults and the fault history. (See page 30 for full list of error codes)

The 2 digit display is controlled by 2 buttons S1 & S2 the flow chart of display modes is shown opposite. Generally, each press of button S2 cycles the display from top to bottom and each press of button S1 cycles the display functions from left to right.

Button S2 is also used to reset the appliance i.e. clear the lockout errors and reset the appliance. (Note: Appliance resetting can also be carried out using the push button on the front panel)

### Display in Normal (Standby) Mode

In the standard /normal mode the 2 digit display indicates the status of the appliance inputs and outputs by switching on the appropriate segments to represent each independant condition in real time. (See table above for possible conditions.)

### Appliance Type Selection

The ElectraMate 'A' class is fitted with an identity (ID) resistor which is read by the controller for comparison with the appliance type (code) set on the controller. The two must match for the cotroller/appliance to function. Therefore if either the appliance code setting or the ID resistor is wrong, the appliance will shut down safely and flag the error code until the fault is rectified. The controller codes and ID resistor values for the ElectraMate are:-

**A04 and 4K7 (yellow sleeving)**

## 2.3 COMMISSIONING

### Front Panel Controls

The appliance user controls consists of an electronic control panel shown opposite and a Danfoss TP 5000 programmable room thermostat which is supplied with the appliance and should have been installed and wired by the installer to the designated terminals in the appliance as detailed in section 2.2. Installation - Wiring the System.

The appliance electronic control panel has a control circuit power supply on-off rocker switch, red LED (lamp) and a push button for resetting the appliance/controller. The functionality of the appliance controller is as follows:

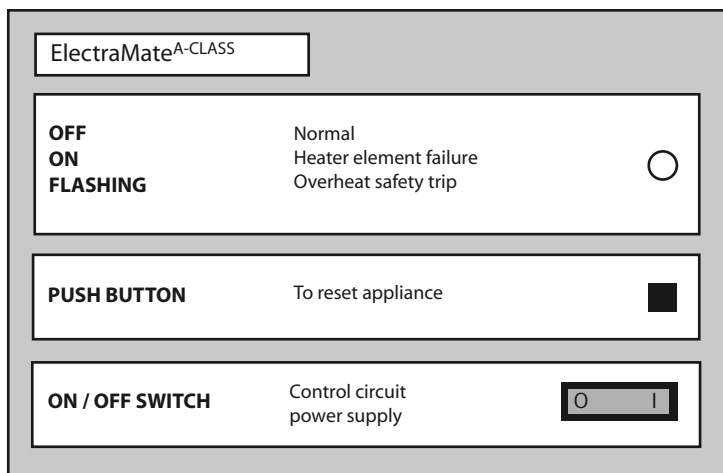

Front Panel Display & Controls

### On-Off Rocker Switch

The switch only isolates the control circuit power supply and therefore it should only be used for switching the appliance off for short periods and for resetting the appliance/controller to clear the lockout faults. Therefore the electricity supplies to the appliance must be isolated at both the on-peak and the off-peak 2 pole local appliance isolators (or single 4 pole isolator) before any service work is undertaken.

### Push Button Functions

A single black membrane button is used to reset the controller/appliance i.e. clear the lockout condition indicated by the flashing red LED.

Red LED (lamp) Conditions:-

- OFF: Normal (Standby or Running)
- ON: Heater Element Failure Detected
- FLASHING: Over Heat Safety Trip.  
**Press push button to reset.**

### Pressure Gauge

A primary system pressure gauge is provided on the front of the appliance to enable the householder to check the central heating system pressure. However, another gauge will be required near to the filling loop to enable the pressure to be checked when the system is being filled/pressurised.

The red pointer should be set during commissioning to the system pressure (normally 1 bar).

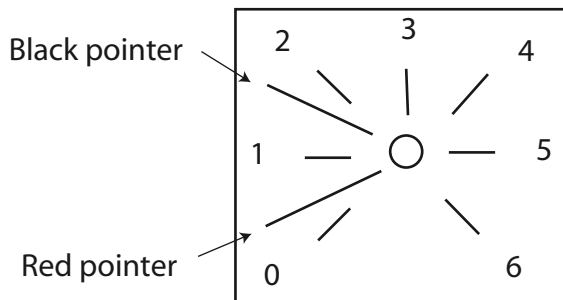

Pressure Gauge

# 2.0 INSTALLATION

## 2.3 COMMISSIONING

**Note** only the hot water circuit is shown for clarity

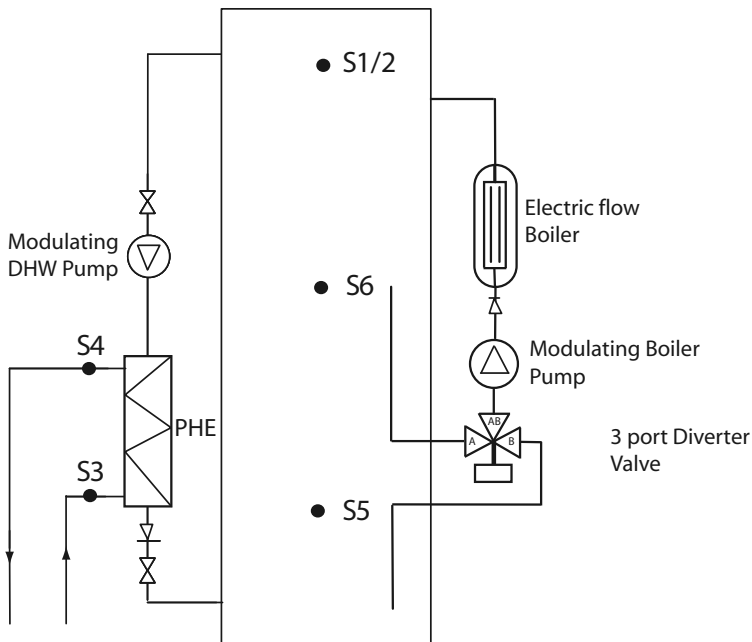

Control logic/Mode of operation - 9 kW

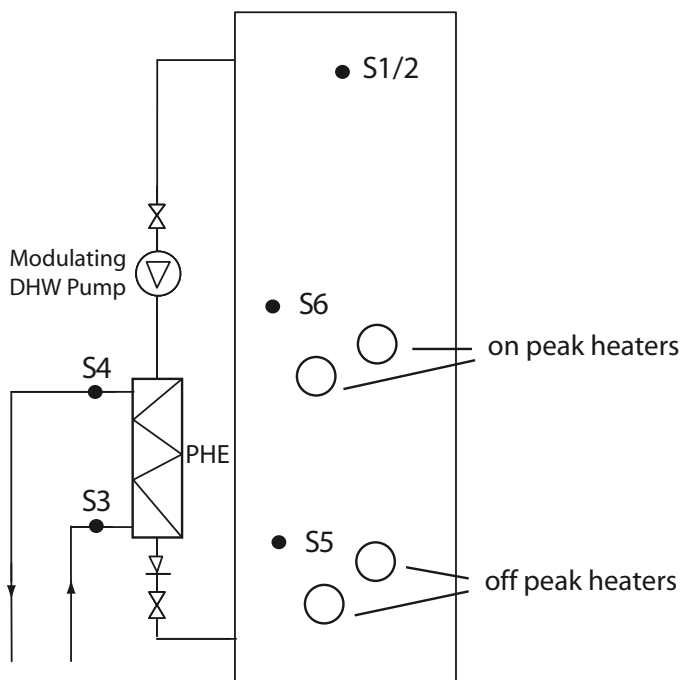

Control logic/Mode of operation - 6 kW

For the control logic T1, T3, T4, T5 and T6 are assumed as the temperatures measured by sensors S1/2, S3, S4, S5 and S6 respectively. The sensor locations are schematically shown opposite for both the 9 and 6kW models. The control set points are shown on the next page.

The controller is designed to suspend all active tasks for a few seconds every 24 hours for checking safety circuits. Following these checks the controller will automatically resume all the suspended tasks. The controller will automatically attempt to schedule this housekeeping activity when it is in the standby mode. Also during this self checking period all devices (e.g. pumps and valves will be exercised).

As can be seen with any sensor error some service will be available but it will be limited and an engineer should be called as soon as possible to restore the appliance to full service levels.

### Thermal Store Heating

As discussed earlier the integrated primary thermal store in an ElectraMate is designed to store the energy during the off-peak (cheaper) electricity tariff periods and this energy is then used indirectly to supply the hot water and central heating requirements. The store charging frequency and store charge temperatures depend upon the heating and hot water demands and the available electricity tariff.

The thermal store heating is not time controlled. The store temperatures measured by sensors S1/S2, S5 and S6 and the off-peak tariff status are used by the controller to heat the store as described below. If sensors S5 and/or S6 are faulty, then the controller will use safety sensors S1/S2 to provide limited store heating service.

When the off peak supply is present, the store heating demand is generated when temperatures T1, T6 and T5 are less than respective off-peak 'on' set points (see table over page). When the store heating demand is generated during off-peak periods, the diverter valve is moved to open port 'B' (9kW) so that total storage volume is heated or the off peak heaters are energised (6kW).

When the off peak supply is not present the store heating demand is generated when temperatures T1 and T6 are less than respective on-peak 'on' set points (see table). When the store heating demand is generated during on-peak period, the diverter valve is moved to open port 'A' (9kW) so that only top storage volume is heated or the in peak heaters are energised (6kW).

When the off peak supply is present, the store heating demand is stopped when temperatures T1 is greater than off peak 'off' set point (eg 87°C) or when both T6 and T5 are greater than respective off-peak 'off' set points (see table).



## 2.3 COMMISSIONING

### Sensor Control Set Points:-

When the off-peak supply is not present, the store heating demand is stopped when both temperature T1 and T6 are greater than on-peak 'off' set point (e.g. 75°C and 70 °C respectively).

When the store heating demand is generated and accepted, the controller will switch on the electric boiler pump and after a random time delay period switch on the first electric boiler element and after another random time delay period switch on the second electric boiler element.

When the store heating demand is active and the electric boiler pump is on, its speed is regulated in relation to temperature, T1, by a PID control loop so that the temperature, T1, reaches the required boiler flow temperature set point which will depend upon the off-peak supply status at that time (e.g. 78°C).

When the store heating demand ceases, the controller will switch off all electric flow boilers elements and will continue to run the boiler pump at minimum pump speed setting for the pump overrun period. After this overrun period, the electric boiler pump will be switched off.

If the store temperature at the top exceeds 95°C. The controller will shut the heat source and activate the overheat safety trip lockout.

### Sensor Error Handling:-

If a fault with sensor S6 is detected then the controller will only use sensors S1 and S5 to control store charge temperature. The store heating demand is generated when T1 is less than 60°C and T5 is less than 45°C. The store heating demand is stopped when T1 is greater than 65°C and T5 is greater than 50°C.

If a fault with sensor S5 is detected then the controller will only use sensors S1 and S6 to control store charge temperature. The store heating demand is generated when T1 is less than 60°C and T6 is less than 45°C. The store heating demand is stopped when T1 is greater than 65°C and T6 is greater than 50°C.

If both sensors S5 and S6 are faulty, then the controller will only sensor S1/S2 to control store charge temperature. The store heating demand is generated when T1 is less than 50°C and the store heating demand is stopped when T1 is greater than 60°C.

If either S1 or S2 is faulty, the controller will shut down the system and safety trip lockout will be activated.

Thermal store heating control settings			
1	Store Sensor, S1 (TOP)	Off-peak 'ON' set point	82°C
		On-peak 'ON' set point	70°C
		Off-peak 'OFF' set point	87°C
		On-peak 'OFF' set point	75°C
		Off-peak boiler flow temperature	78°C
		On-peak boiler flow temperature	70°C
		Maximum (overheat) set point	95°C
2	Store Sensor, S6 (MIDDLE)	Off-peak 'ON' set point	77°C
		On-peak 'ON' set point	65°C
		Off-peak 'OFF' set point	82°C
		On-peak 'OFF' set point	70°C
3	Store Sensor, S5 (BOTTOM)	Off-peak 'ON' set point	70°C
		Off-peak 'OFF' set point	75°C
4	Electric flow boiler pump	Boiler pump overrun period	120s
5	Random delay period between boiler switching stages	Stage 1	10 - 70s
		Stage 2	130-180s

## 2.3 COMMISSIONING

### Central Heating:-

The central heating is controlled by the heat demand signals from the remotely sited programmable room thermostat. The controller senses this demand and switches on the central heating pump when this demand is present and the store temperatures T1 and T6 are greater than the corresponding hot water priority temperature setting (65°C and 58°C) respectively.

When the central heating demand is active, then if either T1 or T6 drops below respective (61°C and 54°C), the controller switches off the central heating pump until both T1 and T6 are above the priority set points.

Standard central heating pump: If a non-modulating i.e. a standard pump is fitted, then it will run at constant speed corresponding to the setting on the pump irrespective of the return temperature, T5.

Modulating central heating pump (available only as an optional extra): When the central heating demand is active and the central heating pump is on, its speed is regulated in relation to T5, by a PID control loop so that T5, reaches the heating return temperature set point (say 55°C).

When the central heating demand ceases from either the central heating programmer or the room thermostat, the controller switches off the central heating pump after an overrun period of 5s.

### Sensor error handling

If a fault with sensor S6 is detected then the controller will ignore the hot water priority logic associated with this sensor and the CH pump will switch on demand irrespective of the store temperature.

If a fault with sensor S5 is detected then the controller will not modulate the CH pump and its setting will be set to maximum. All faults will be logged.

1	Store sensor, S1	HW priority temperature setting	65°C
		HW priority setting hysteresis	-4°C
2	Store sensor, S6	HW priority temperature setting	58°C
		HW priority setting hysteresis	-5°C
3	Store sensor, S5	CH return setting	55°C
		CH return setting hysteresis	-3°C

### 3.3 Domestic hot water generation

The mains pressure hot water is heated instantaneously by means of a plate heat exchanger which transfers the heat from the pre-heated primary stored water to the secondary (DHW) water.

#### Plate heat exchanger (PHE) warm up cycle

A PHE warm up cycle is provided for reliable detection of a hot water demand. In practice this is very rarely triggered because of heat conduction and high ambient temperature inside the appliance case.

If hot water demand is not active and temperature T3 is less than 32°C and the temperature T6 is greater than 38°C, then controller will switch on the PHE pump at minimum speed setting (speed 1) to start the PHE warming cycle.

The PHE warm up cycle will continue until either T3 is greater than 35°C or T6 is less than 38°C or a hot water demand has been sensed.

PHE warm up cycle will not be initiated until at least 10s after the end of a hot water demand.

#### Hot water demand i.e. flow detected

The hot water demand is detected if the rate of decrease of temperature, T3, is greater than 2°C/s or if temperature, T3, is less than 25°C.

The loss of hot water demand is sensed if either temperature T3, is greater than 30°C or if temperature, T4, is greater than 80°C.

The loss of hot water demand is also triggered if the demand has been continuous for more than 30 minutes.

#### Hot water temperature control

If a hot water demand is sensed, the controller switches on the PHE pump at fast speed for about 1s and then uses the PID loop to control the PHE pump speed to maintain the hot water temperature, T4, at 52°C.

If during a hot water demand, temperature, T4 exceeds 80°C, the controller will switch off the pump and will restart it when, T4, is less than 52°C.

#### Sensor error handling

If the controller detects and registers a fault with sensor, S4 only and a hot water demand is sensed, then the controller will run the PHE pump at constant speed of 50% of maximum (i.e. at mid-point setting).



## 2.3 COMMISSIONING

Table EMA_5: DHW control set points			
1	CW inlet sensor, S3	PHE warm up OFF set points	35°C
		PHE warm up set point hysteresis	3°C
		PHE warm up ON set point (35 - 3)	32°C
		Rate of change for detecting flow rate	2°C/sec
		DHW demand end temperature	30°C
		Set point for detecting low flow rates (30-3-2)	25°C
2	DHW outlet sensor, S4	DHW control set point	52°C
		DHW control set point hysteresis	25°C
		DHW off safety set point	80°C
3	Middle store sensor, S6	Minimum store temperature measured by sensor, S6 set point for PHE warm up cycle to start (35 + 3) <sup>(1)</sup>	38°C
4	Timers	PHE warm up delay period timer (2)	10s
		Maximum DHW continuous on period timer	1800s

**Notes:**  
 1. If store temperature is below this value, then the PHE warm up cycle will not be started  
 2. Delay period for PHE warm up cycle to start following a draw-off.

### Appliance Controller Error Codes and Description Table

LOCKING_ERROR_TABLE		BLOCKING_ERROR_TABLE		ERROR_TABLE_DHW	
Code No.	Definition	Code No.	Definition	Code No.	Definition
255	NO_ERROR	29	WD_COMMUNICATION_ERROR	255	NO_ERROR
0	E <sup>2</sup> PROM READ ERROR	30	PHASE_ERROR	0	T_DHW_OUT_OPEN
1	SAFETY RELAY ERROR	31	50HZ_ERROR	1	T_DHW_IN_OPEN
2	E <sup>2</sup> PROM ERROR	32	RESET_BUTTON_ERROR	2	T_DHW_OUT_SHORTED
3	WRONG E <sup>2</sup> PROM SIGNATURE	33	APPLIANCE SELECTION ERROR	3	T_DHW_IN_SHORTED
4	ROM ERROR	37	T_OVERHEAT_1_OPEN		
5	RAM ERROR	38	OPEN_SENSOR_1		
10	OVERHEAT ERROR	39	OPEN_SENSOR_2		
11	OVER HEAT DIFFERENCE ERROR	40	T_ID_OPEN		
12	T_MAX LOCK ERROR	44	T_OVERHEAT_2_OPEN		<b>WARNING_TABLE</b>
23	BOILER RELAY ERROR	45	T_OVERHEAT_1_SHORTED	<b>Code No.</b>	
24	EH_RELAY_ERROR	46	SHORTED_SENSOR_1	255	NO_ERROR
		47	SHORTED_SENSOR_2	0	T_TANK_MIDDLE_OPEN
		48	T_ID_SHORTED	1	T_TANK_BOTTOM_OPEN
		46	SHORTED_SENSOR_1	2	T_TANK_MIDDLE_SHORTED
		52	T_OVERHEAT_2_SHORTED	3	T_TANK_BOTTOM_SHORTED
		54	ID_ERROR	7	FULL_IH_WARNING
				8	PART_IH_WARNING

## 2.0 INSTALLATION

### 2.3 COMMISSIONING

#### Powering the system/appliance

The appliance will automatically commission when it is switched on. However it is essential that the following steps are carried out to check the correct functioning of all the controls.

Before switching ON the mains supply to the appliance check that :

1. The mains electrical supply and room thermostat are correctly connected and the MCB protection device is of the correct rating.
2. Programmable Room Thermostat is correctly wired to the appliance terminals as detailed earlier in this manual.

The control system/ACB has been initialised at the factory and will operate automatically.

#### Programmable Room Thermostat

To test space heating first check the programmable room thermostat (TP5000). Flip down the lower button cover to reveal the programming buttons (PROG, +, -). Press the + and - buttons together until the display shows the actual room temperature. In the middle of the right hand side of the LCD display the current set point temp. value will be displayed, this is the temperature that the ElectraMate is controlling to. The programmed control temperature may be changed temporarily using the ▲ and ▼ buttons until the required temperature is shown.

A ▲ or ▼ arrow will appear in the display as a reminder that the programmed setting has been over-ridden. This over-ride is cancelled at the next programmed switching.

The large display in this mode is indicating the current actual temperature of the room.

Press the ▲ button once for each degree increase until a flame symbol is displayed and a click is heard.

The 2 digit display on the appliance ACB will now indicate that the Room thermostat is calling for heat by lighting segment V1.4 of the seven segments (see left), and the water from the store will be circulated to the radiators by the heating pump. You will also notice a second vertical bar V1.3 to the left of the room thermostat bar this will always be on if 'SL-W' has the bridge link fitted.

**We attach a plastic bag with two links supplied for the Installer to fit once the whole system is completed, one for 'SL-W' the second 'SL-H' . These links must be fitted to be able to commission/ operate the appliance.**

#### Danfoss TP5000 Programmable Room Thermostat

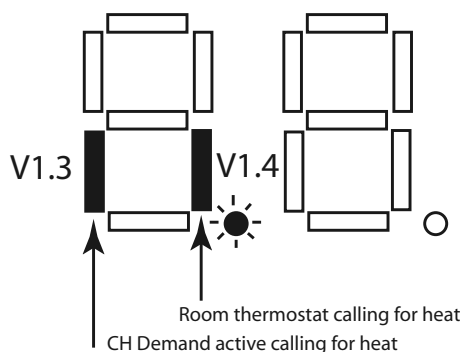

## 2.3 COMMISSIONING

Switch off space heating from the programmable room thermostat.

A Vertical bar on the 2 digit screen (V1.4 see below) will switch off and the heating pump will stop circulating water to the radiator circuit.

1. Check operation of 'on-peak / off-peak' detection by switching MCB 4 off the 3 port diverter valve will motor across and the plastic white indicator will move to the left, now switch MCB 4 back to on and the valve will motor the other way to the the right. When an 'off-peak' signal is present, the vertical bar V2.4 will indicate, when the 'off peak' signal is not present vertical bar V2.4 will go out and V2.3 will indicate, 'on -peak' only condition. See key below for 2 digit display diagram, this will help identify which bar relates to each condition.

2. Turn the hot water tap on and off. When the hot water tap is opened the horizontal bar H2.1 (PHE demand) will light when the hot water is running.

**Note:** The heating pump will automatically be switched off when hot water is being drawn.

If the store is calling for heat then the 2 digit display will show if one or both Electric flow boiler elements are active, and indicate on the vertical bar V2.1 1st element active and V2.2 2nd element active, the heater elements are now receiving a supply via their respective control power relays.

- see wiring diagram in Section 2.2 Installation for further details.

To keep the cupboard temperature to a minimum in summer it is recommended that any exposed hot water/heating pipework in the cupboard is insulated.

A bridge link is provided which should be fitted during commissioning/testing between terminals 'L' & 'SL-W' on the appliance terminal rail to allow the appliance to be charged automatically at any time under control of the PCB store sensors.

The internal controls automatically select the store charge temperature and control temperature differential to suit the electricity tariff. The temperature settings established during commissioning can be checked using push button switches S2 and S1 on the PCB below the 2 digit display, as described in Section 2.3 commissioning page 25.

**This product is covered by the 'Benchmark' scheme and a commissioning/service log sheet which will meet the requirements of Building Regulations ADLI for a commissioning certificate is included as part of these installation instructions. This must be completed during commissioning to meet the warranty conditions offered by Gledhill.**

On completion :

1. Do ensure that the electrical connections (e.g. mains supply, programmable room thermostat) to the unit are correct and tight.
2. Do ensure that the functioning and control of the system including the programmable room thermostat is explained to the occupant.
3. **DON'T** place any clothing or other combustible materials against or on top of this appliance.

These Instructions should be placed along with the component manufacturers instructions in the pocket provided on the rear of the front panel. The front panel should then be refitted.

When the system has been commissioned and all the air released from the C.H. system close the AAV cap.

Use the AAV as necessary in the future when carrying out any repairs/modifications to the C.H. system e.g. removing a radiator for decorating. When the radiator is re-fitted the sealed circuit will need to be recharged to the correct system pressure (normally to one bar). We have fitted a pressure gauge on the front of the unit to give a quick indication, to the householder, of the sealed heating system condition.

**Always remember to close the AAV cap once all work is complete and tested.**

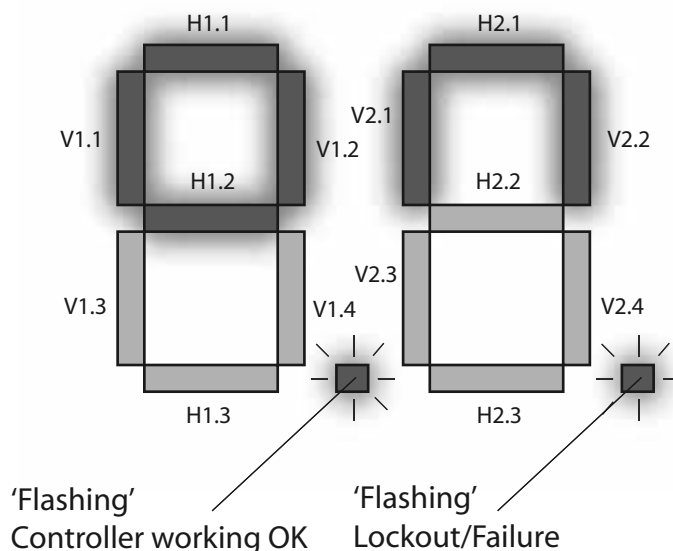

LED	Description
H1.1	Middle store sensor calling for heat
H1.2	Bottom store sensor calling for heat
H1.3	Spare not used
V1.1	HW Programmer calling for heat
V1.3	CH Programmer calling for heat
V1.4	Room thermostat calling for heat
H2.1	PHE pump running
H2.2	CH pump running
H2.3	Flow Boiler pump running (9kW)
V2.1	1st Electric Heater Element On
V2.2	2nd Electric Heater Element On
V2.3	3 Port Diverter Valve ON-PEAK mode (9kW)
V2.4	3 Port Diverter valve OFF-PEAK mode (9kW)

## 3.0 SERVICING

### 3.1 ANNUAL SERVICING

No annual servicing of the ElectraMate A-Class is necessary.

However, we would recommend that checks on the appliance controls and a hot water performance test are carried out annually to prove the appliance is working satisfactorily and within its specification.

### 3.2 CHANGING/ COMPONENTS

**This appliance has two independent electrical supplies. Ensure that both supplies are isolated at the 4 pole isolator (or 2x 2 pole isolators) before removing the front panel to undertake any work.**

Free of charge replacements for any faulty components are available from Gledhill during the initial in-warranty period (normally 12 months).

After this, spares can be obtained direct from Gledhill using the 'Speed Spares' service, or through any of the larger plumbers merchants/ specialist heating spares suppliers.

Help and advice is also available from the Technical Helpline on 08449 310000.

However, all components are readily accessible and can be changed quickly and easily by the installer using common plumbing practice.

If it is necessary to replace any of the pumps fitted to the appliance the pump head (motor pack) only should be removed as recommended by Grundfos. Assuming it is within warranty this will be accepted by a merchant as being covered by the Grundfos national service exchange agreement, as long as it is a complete pump i.e. alleged faulty motor pack and new base is left with the merchant. It is important when a pump has been replaced to ensure that any air is adequately vented.

**NOTE:** The electric boiler pump and PHE pump are both Grundfos UPR 4 wire type and any replacement must be the same model.

**WARNING :** There are not user serviceable parts inside the appliance cover. All annual inspections and/or servicing must only be carried out by suitably qualified and competent persons.

# 3.0 SERVICING

## 3.3 SHORT PARTS LIST

	Description	Supplier & Model	Part Number	Stock Code	Models
1	PHE Pump	Grundfos, UPR 15-50 (1" modulating)	59505432	GT089	All - standard
2	Plate heat exchanger (PHE)	SWEP, 24 Plate heat exchanger	E8T/24	GT017	All
3	PHE pump isolating valve - inlet	Martin Orgee, 90° valve with NRV	7308123	GT135	All
4	PHE pump isolating valve - outlet	Martin Orgee, Straight valve	40210	GT133	All
5	CW inlet Y-line strainer	Vemco 22mm Compression Y strainer	n/a	XB314	All
6	Electric boiler pump	Grundfos, UPR 15-50 (1" modulating)	59505432	GT089	All - standard
7	Central heating pump	Grundfos, UPR 15-50 (1" modulating)	59505432	GT089	All - optional
		Grundfos, UPS 15-50 (1½" - standard)	59525452	XB004	All - standard
8	Electric boiler pump isolating valves	Martin Orgee, 90° valve - INLET	7308123	GT135	All
		Martin Orgee, Straight valve - OUTLET	40210	GT133	All
9	Central heating pump isolating valves	Martin Orgee, 90° valve - INLET	7308123	GT135	All - optional
		Martin Orgee, Straight valve - OUTLET	40210	GT133	All - optional
		Vemco , 22mm ball type (Inlet & Outlet)	PV222SB	XB121	All - standard
10	9kW Electrical Flow Boiler	Wardtec type: 1 off for 6kW model 1 off for 9kW model		t.b.a. XB342	EMA 225/6 EMA 225/9
11	Main PCB controller	Argus Vision 147_30_25B0 controller	147/3GS	XB442	All
12	Bottom store sensor	Tasseron, Single sensor	TSK10B4	GT198	All
13	Middle store sensor	Tasseron, Single sensor	TSK10B4	GT198	All
14	Top (OHT) sensor	Tasseron, Duplex sensor	TSK11B4	GT199	All
15	Front panel display	R H Technical, Membrane overlay	P211294	XB431	All
16	Front panel display wiring harness	R H Technical, Membrane harness	NCA200NN04D	XB057	All
17	Internal fuses/circuit protection	Control circuit: 2 x 6A MCB	NB106	XB025	All
		Switch circuit: 2 x 20A MCB	NB120	XB027	EMA 225/9
18	Power Relays	Relpol RG25 2 pole power relay	RG25	GD263	All
19	Interface Relay	Relpol change over relay	RM87N-2311-35-5230	XB424	EMA 225/9
20	Complete DIN Rail assembly	Wago, Bespoke terminal & components	t.b.a	t.b.a.	All
21	Complete wiring harness		t.b.a.	t.b.a.	All
22	On-Off switch (part of panel)	Arcoelectric, Green illuminated rocker switch	C5503-ALNAK	CA006	All
23	Programmable room thermostat	Danfoss	TP 5000	XB365	All
24	3-Port Valve	Honeywell	VC6012	GT047	EMA 225/9
25	CH Pressure Gauge Square 6 bar	IMI Capillary Pressure Gauge	IM100049	GT179	All
26	Electronic Scale Inhibitor	Elok	SP01	XB142	All - optional
27	4 Pole Isolation Box	Hagar	n/a	AECK001	All - optional
29	20 mm Glass Cartridge fuse	RS (Bussman) 20mm T 3.15 250V	265-0821	t.b.a	All
30	Flow Boiler Over Heat Thermostat	NGT Self Resetting Thermostat A95°C	03EN6949	GT455	EMA 225/9
31	3 pole interposing relay				EMA 225/6
32	3kW immersion heater				EMA 225/6

# 3.0 SERVICING

## 3.3 SHORT PARTS LIST



2



7



9

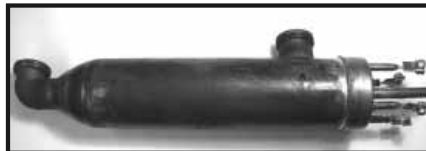

10



11



13



14



15



16



17



18



19



22



23



24



25

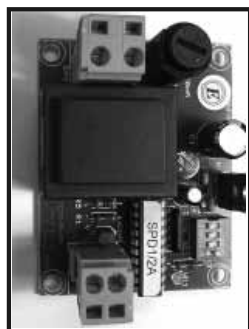

26



27



29



31



30



32

## FAULTS AND THEIR CAUSES

Any fault in the system design or malfunction of system components will generate customer complaints. These can be grouped into the following three main categories:-

- The system is noisy
- Hot water service is unsatisfactory
- Space heating service is unsatisfactory

## CAUSES OF A 'NOISY' SYSTEM

Noisy heating pump operation:-

- Check the pressure in the system, which should not be less than 1.0 bar when cold and vent if necessary.
- Check the pump speed setting of the heating system pump - reduce if necessary but ensure that the temperature difference is about 11°C.
- If the system is noisy when in heating mode only - check and adjust if necessary the system bypass (if fitted).

Noisy electric boiler/heater operation:-

- On the 9kW model check the flow rate through the integral electric boiler when switched on by measuring the temperature rise across the boiler. If the temperature rise is greater than 11°C, then increase the pump speed.
- Check the pressure in the system which should not be less than 1.0 bar when cold and vent if necessary.

Noise when hot water is opened:-

- If the pump is noisy when the hot water tap is opened, then check the system pressure which should not be less than 1.0 bar and vent the pump if necessary.
- Water hammer - loose pipework and/or tap washers.

## CAUSES OF 'UNSATISFACTORY HOT WATER SERVICE'

1. Check the F & E tank level and top up to fill line if required.
2. On the 9kW check that the electric flow boiler is working normally.
3. Check that the store is being charged to the correct set point temperatures for the on/off peak supply as shown in Section 2.3 Commissioning.
4. Check that the hot water plate heat exchanger pump starts when the hot water tap is opened and stops shortly after the tap is closed.
5. Check that the plate heat exchanger pump has no air lock and or cavitating.
6. Check that the hot water outlet temperature does not change significantly when the hot water flow rate is increased from say 5 litres/min to 15 litres/min.
7. Check that the space heating load is not greater than specified for the unit and that the occupant knows how to use the programmable room thermostat.
8. If 1 to 7 are correct then it is likely that the performance of the heat exchanger is impaired by scale. In this case the hot water flow rate will be noticeably less than the cold. Replace it with a factory exchange unit and re-check hot water performance. At the same time check the hardness level and if this is over 200ppm (mg/e) then fit a suitable inline scale inhibitor.

## 3.4 FAULT FINDING

### CAUSES OF 'UNSATISFACTORY SPACE HEATING'

1. Check the pressure in the system which should not be less than 1.0 bar.
2. Check that the electric boiler/heater is working.
3. Check that the space heating load is not greater than specified for the unit.
4. Check that the flow temperature is at least 70°C.
5. Check the operation and the settings of the programmable room thermostat.
6. If some rooms are not being heated properly, then increase the pump speed to establish a temperature difference of 11°C and if necessary balance the system/ check the operation of any TRV's.

### POWERFLUSHING/ CLEANING OF THE HEATING SYSTEM

If it is proposed to 'powerflush' the heating system we would recommend that the ElectraMate appliance is isolated from the heating system being cleaned. Failure to do this could seriously damage the appliance.

When carrying out the work always comply fully with the manufacturers instructions for the powerflushing equipment being used.

If in any doubt please consult our Technical Helpline.

## WATER SAVINGS

WATER RELATED COSTS CAN BE REDUCED BY GOOD PLUMBING PRACTICE.

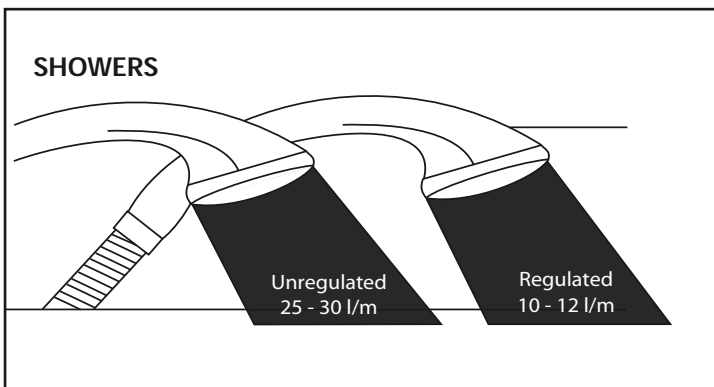
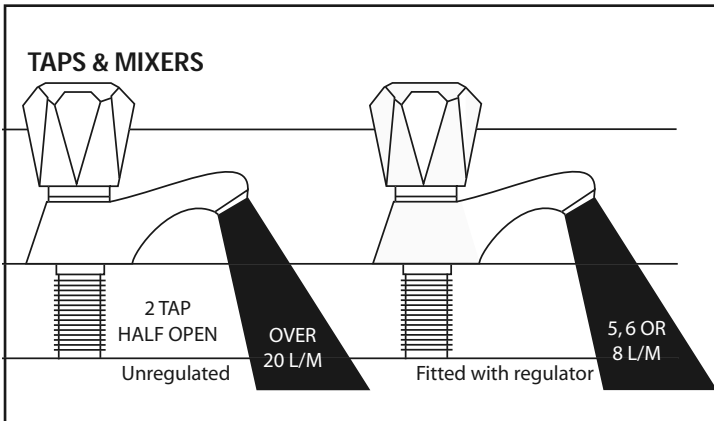

Vast quantities of water are needlessly run off to waste due to Taps, Mixers and Showers discharging flow rates far in excess of the rates required for them to perform their duties.

The contrasting flow rates shown on this leaflet clearly illustrate the savings that can be made whilst still providing a good performance.

British made Aquaflow Regulators provide constant flow rates by automatically compensating for supply pressure changes between 1 bar & 10 bars.

To facilitate installation into the wide range of plumbing equipment which is encountered in the U.K, Four Fixing Options are available:-

## OPTIONS FOR SHOWERS

1. MXF "DW" Range - For fitting behind Fixed Shower Heads or onto Flexible Hoses for Handshowers (preferably onto the inlet end when lightweight hoses are used).
2. Compression Fitting Range. "In Line" regulators as in Option 4 for Taps & Mixers.

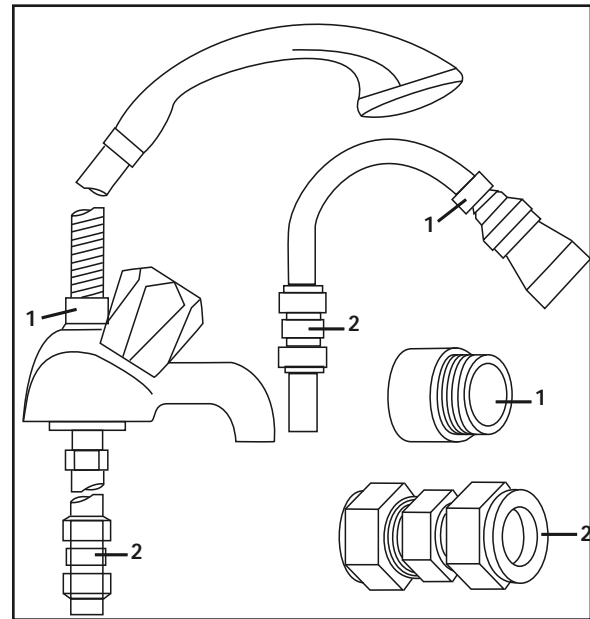

## 4 FIXING OPTIONS FOR TAPS & MIXERS

1. MK Range - Combined Regulators & Aerator for screwing onto Taps & Mixers with internal or external threads on their noses. Anti Vandal models also available.
2. MR05-T Range - Internal Regulators. Push-fit into Tap or Mixer seats. Produced in three sizes - 12.5mm (BS1010), 12mm & 10mm, Flangeless models also available for Taps with Low Lift washers.
3. MXF Standard Range - Screw on tail models for Taps & Mixers. Fix onto the tails before fitting the tap connectors. Available in 3/8", 1/2", 3/4" and 1" BSP.
4. Compression Fitting Range - "In Line" regulators housed in 15mm & 22mm CXC Couplers & Isolating Valves. UK WFBS listed by the Water Research Centre. Isolation valves available for slotted screwdriver operation or with coloured plastic handles. Now available also in plastic bodied push-fit couplers & valves.

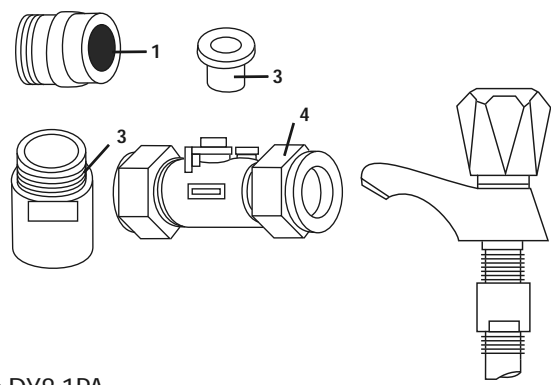

Information by courtesy of

**AQUAFLOW REGULATORS LTD**

Haywood House, 40 New Road, Stourbridge, West Midlands DY8 1PA  
TELEPHONE (01384) 442611 FAX: (01384) 442612



# APPENDIX B

## MANIFOLDS

Manifold type: 1 - Stock Code MIP 050 (one bathroom, one en suite shower room, one cloakroom, one kitchen)			
Flow regulator (litres/minutes)	Terminal fitting	Hot water manifold outlets Quantity	Cold water manifold outlets Quantity
18	Bath tap	1	1
9	Hand basin	3	3
12	Kitchen sink	1	1
9	Toilet cistern	None	3
9	Shower	1	1
12	Washing machine	1	1
9	Dishwasher	None	1
Total		7	11

Two sets of manifolds are available as an optional extra. Each set comprises a separate hot and cold water manifold. Both are provided with a 22mm inlet connection located centrally. All outlet connections are 15mm compression. The centre to centre dimension of each branch is 55mm.

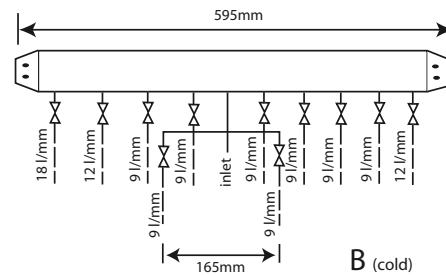
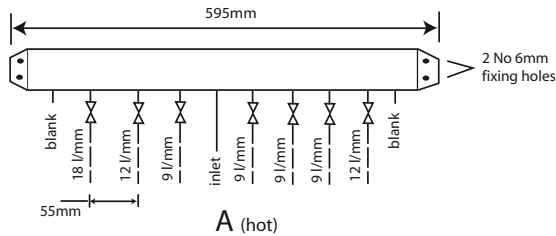

Manifold type: 2 - Stock Code MIP 060 (two bathrooms, one en suite shower room, one cloakroom, one kitchen, one utility room)			
Flow regulator (litres/minutes)	Terminal fitting	Hot water manifold outlets Quantity	Cold water manifold outlets Quantity
18	Bath tap	2	2
9	Hand basin	4	4
12	Kitchen sink	2	2
9	Toilet cistern	None	4
9	Shower	1	1
12	Washing machine	1	1
9	Dishwasher	None	1
Total		10	15

The arrangement of each manifold is supplied as shown. This provides the best balance of flows but the flow regulators/duty of each branch can be changed if required as long as a reasonable balance is maintained. If it is necessary to change or clean the flow regulator this can be done without needing to drain the system by closing the valve and removing the screwed cover below the white plastic cover.

The manifolds are designed to be used with plastic pipework and are supplied complete with isolation valves and flow regulators on each branch. They would normally be installed in the same cupboard as the thermal storage appliance (as shown below) but can be installed in another cupboard close to the appliance if required.

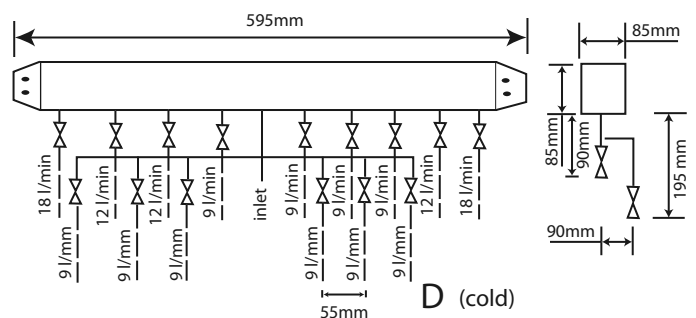
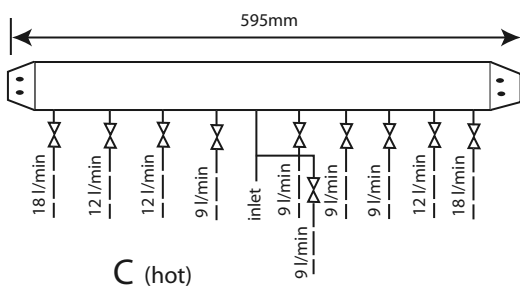

# APPENDIX B

*An optional location where cupboard space is tight*



The pressure loss through a flow regulator at the designated flow rate is about 1.8 bar. Therefore for the flow regulator to control the flow rate at pre-set level, the inlet pressure must be greater than 1.8 bar. If the inlet pressure is lower, the flow rate will be correspondingly less than the pre-set values.

The maximum equivalent pipe lengths from the manifold to the terminal fittings can be estimated from the above information and the resistance characteristics of the pipes. The examples presented below are for 15mm copper pipe in table 1 and for plastic pipework in table 2.



*The preferred solution where space will allow*

Table 1: Maximum equivalent pipe length in 15mm copper			
Inlet pressure (bar)	Maximum equivalent length of pipe (m)		
	@ 9 l/m	@ 12 l/m	@ 18 l/m
2.0	25	10	5
2.5	75	30	15
3.0	150	60	30

Table 2: Maximum equivalent pipe length in plastic pipe			
Inlet pressure (bar)	Maximum equivalent length of pipe (m)		
	@ 9 l/m	@ 12 l/m	@ 18 l/m
2.0	1.5	15mm : 10	15mm : 4.5 22mm : 40
2.5	3.0	15mm : 20	15mm : 9.0 22mm : 80.0

# APPENDIX B

The size of the distribution pipes supplying the manifold should be calculated using the method set out in BS 6700. A typical diagrammatic arrangement of a system using Manifold Type 1 is shown below.

This is only meant to show the principles involved and the actual connection of fittings to the manifold will need to suit the arrangements shown on page 35.

**Note 1** - If it is proposed to fit chemical water treatment such as a water softener this should be fitted in this location and the cold water branch in the sink should be branched off the cold water main prior to the treatment device instead of the cold water manifold.

Any other isolating/control valves and backflow protection devices should be provided as necessary to comply with the Water Regulations.

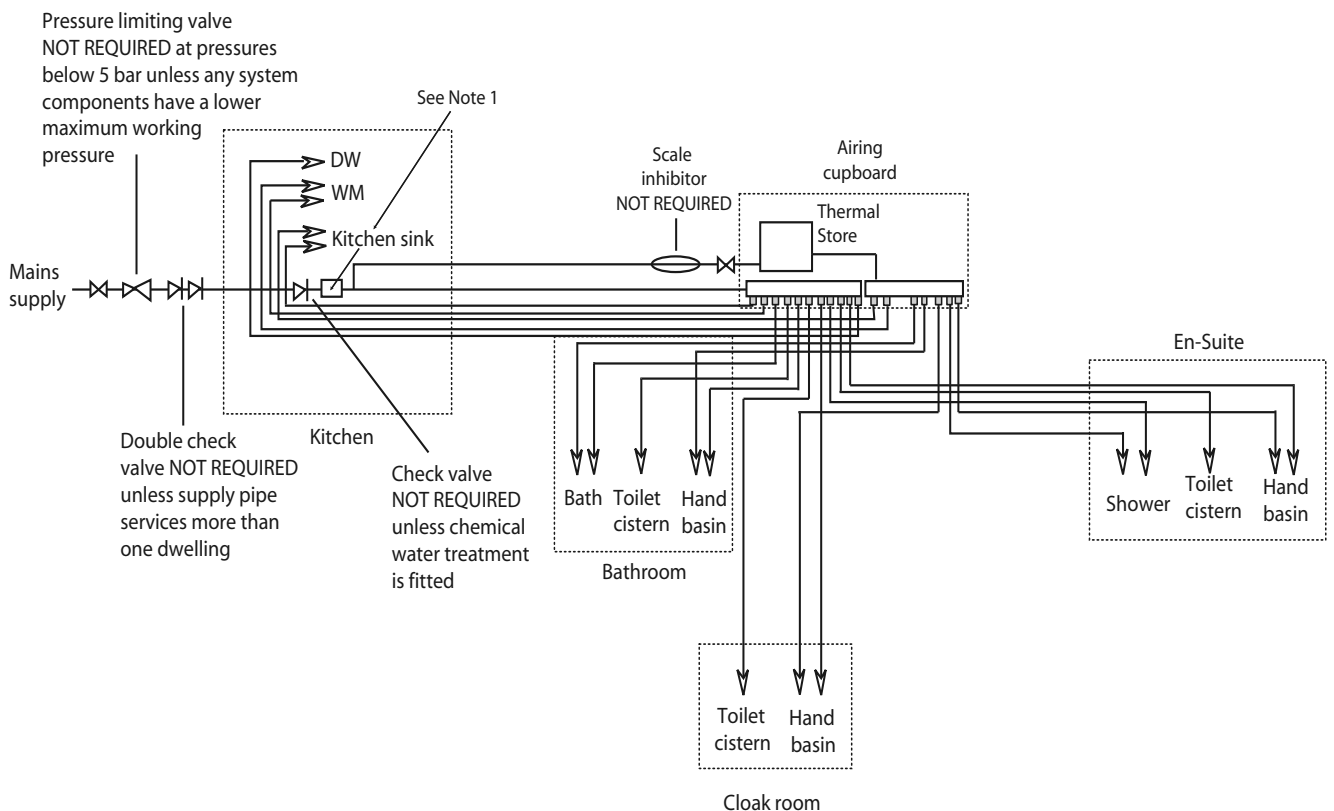



## 2 Inhibitor (Corrosion & scale protection of primary heating circuit)

On filling the heating system and before the boiler is fired up, it is important to ensure the system water is treated with a suitable corrosion inhibitor, in accordance with the boiler manufacturer's instructions.

Since the concentration of inhibitor present in a system can become diluted, for a number of different reasons, the system should be checked annually and re-treated as required, or after every full or partial drain-down. A water treatment manufacturer's test kit may be used to check the correct concentration of inhibitor in the system.

Where recommended by a boiler manufacturer, a 'physical corrosion protection device' may be fitted in the primary pipework in accordance with the boiler manufacturer's instructions.

The Benchmark log book should be completed indicating the date and details of any of the above products added and a permanent label should be fixed to the system in a prominent location.







## 3 Scale protection (Domestic hot water service)

Where a combi boiler and/or a hot water storage vessel is installed in areas where the mains water can exceed 200ppm Total Hardness (as defined by BS 7593: 1993 Table 2) a scale reduction device should be installed, in accordance with the boiler manufacturer's instructions. The levels of water hardness may be measured using a water hardness test kit.

### BUILDING REGULATIONS

Completion of the BENCHMARK log book requires that the 'competent person' undertaking the installation and commissioning provide information relating to Cleaning, Inhibitor and Scale Protection. This will demonstrate that the work complies with the requirements of the appropriate Building Regulations.

This Guidance Note is produced on behalf of its members by the Central Heating Information Council. For a full list of members visit [www.centralheating.co.uk](http://www.centralheating.co.uk) and for further advice on water treatment contact the following members:

 Culligan  Sentinel  Ferno  Salamander Engineering  Scalmaster

Heating & Hotwater Information Council, 36 Holly Walk, Leamington Spa,  
Warwickshire CV32 4LY Tel: 0845 600 2200 Fax: 01926 423284  
[www.centralheating.co.uk](http://www.centralheating.co.uk)



Benchmark is managed by The Heating & Hotwater Information Council

# APPENDIX D



BENCHMARK No. | | | | | | | |

## GAS BOILER COMMISSIONING CHECKLIST

BOILER SERIAL No. \_\_\_\_\_ NOTIFICATION No. \_\_\_\_\_

**CONTROLS** To comply with the Building Regulations, each section must have a tick in one or other of the boxes

TIME & TEMPERATURE CONTROL TO HEATING	ROOM T/STAT & PROGRAMMER/TIMER <input type="checkbox"/>	PROGRAMMABLE ROOMSTAT <input type="checkbox"/>
TIME & TEMPERATURE CONTROL TO HOT WATER	CYLINDER T/STAT & PROGRAMMER/TIMER <input type="checkbox"/>	COMBI BOILER <input type="checkbox"/>
HEATING ZONE VALVES	FITTED <input type="checkbox"/>	NOT REQUIRED <input type="checkbox"/>
HOT WATER ZONE VALVES	FITTED <input type="checkbox"/>	NOT REQUIRED <input type="checkbox"/>
THERMOSTATIC RADIATOR VALVES	FITTED <input type="checkbox"/>	
AUTOMATIC BYPASS TO SYSTEM	FITTED <input type="checkbox"/>	NOT REQUIRED <input type="checkbox"/>

### FOR ALL BOILERS CONFIRM THE FOLLOWING

THE SYSTEM HAS BEEN FLUSHED IN ACCORDANCE WITH THE BOILER MANUFACTURER'S INSTRUCTIONS?

THE SYSTEM CLEANER USED \_\_\_\_\_

THE INHIBITOR USED \_\_\_\_\_

### FOR THE CENTRAL HEATING MODE, MEASURE & RECORD

GAS RATE  m<sup>3</sup>/hr  ft<sup>3</sup>/hr

BURNER OPERATING PRESSURE (IF APPLICABLE)  N/A  mbar

CENTRAL HEATING FLOW TEMPERATURE  °C

CENTRAL HEATING RETURN TEMPERATURE  °C

### FOR COMBINATION BOILERS ONLY

HAS A WATER SCALE REDUCER BEEN FITTED? YES  NO

WHAT TYPE OF SCALE REDUCER HAS BEEN FITTED? \_\_\_\_\_

### FOR THE DOMESTIC HOT WATER MODE, MEASURE & RECORD

GAS RATE  m<sup>3</sup>/hr  ft<sup>3</sup>/hr

MAXIMUM BURNER OPERATING PRESSURE (IF APPLICABLE)  N/A  mbar

COLD WATER INLET TEMPERATURE  °C

HOT WATER OUTLET TEMPERATURE  °C

WATER FLOW RATE  lts/min

### FOR CONDENSING BOILERS ONLY CONFIRM THE FOLLOWING

THE CONDENSATE DRAIN HAS BEEN INSTALLED IN ACCORDANCE WITH THE MANUFACTURER'S INSTRUCTIONS? YES

### FOR ALL INSTALLATIONS CONFIRM THE FOLLOWING

THE HEATING AND HOT WATER SYSTEM COMPLIES WITH CURRENT BUILDING REGULATIONS

THE APPLIANCE AND ASSOCIATED EQUIPMENT HAS BEEN INSTALLED AND COMMISSIONED IN ACCORDANCE WITH THE MANUFACTURER'S INSTRUCTIONS

IF REQUIRED BY THE MANUFACTURER, HAVE YOU RECORDED A CO/CO<sub>2</sub> RATIO READING? N/A  YES  CO/CO<sub>2</sub> RATIO

THE OPERATION OF THE APPLIANCE AND SYSTEM CONTROLS HAVE BEEN DEMONSTRATED TO THE CUSTOMER

THE MANUFACTURER'S LITERATURE HAS BEEN LEFT WITH THE CUSTOMER

COMMISSIONING ENG'S NAME PRINT \_\_\_\_\_ CORGI ID No. \_\_\_\_\_

SIGN \_\_\_\_\_ DATE \_\_\_\_\_

# SERVICE INTERVAL RECORD

It is recommended that your heating system is serviced regularly  
and that you complete the appropriate Service Interval Record Below.

**Service Provider.** Before completing the appropriate Service Interval Record below, please ensure you have carried out the service as described in the boiler manufacturer's instructions. Always use the manufacturer's specified spare part when replacing all controls

## SERVICE 1 DATE \_\_\_\_\_

ENGINEER NAME \_\_\_\_\_

COMPANY NAME \_\_\_\_\_

TEL No. \_\_\_\_\_

CORGI ID CARD SERIAL No. \_\_\_\_\_

COMMENTS \_\_\_\_\_

SIGNATURE \_\_\_\_\_

## SERVICE 2 DATE \_\_\_\_\_

ENGINEER NAME \_\_\_\_\_

COMPANY NAME \_\_\_\_\_

TEL No. \_\_\_\_\_

CORGI ID CARD SERIAL No. \_\_\_\_\_

COMMENTS \_\_\_\_\_

SIGNATURE \_\_\_\_\_

## SERVICE 3 DATE \_\_\_\_\_

ENGINEER NAME \_\_\_\_\_

COMPANY NAME \_\_\_\_\_

TEL No. \_\_\_\_\_

CORGI ID CARD SERIAL No. \_\_\_\_\_

COMMENTS \_\_\_\_\_

SIGNATURE \_\_\_\_\_

## SERVICE 4 DATE \_\_\_\_\_

ENGINEER NAME \_\_\_\_\_

COMPANY NAME \_\_\_\_\_

TEL No. \_\_\_\_\_

CORGI ID CARD SERIAL No. \_\_\_\_\_

COMMENTS \_\_\_\_\_

SIGNATURE \_\_\_\_\_

## SERVICE 5 DATE \_\_\_\_\_

ENGINEER NAME \_\_\_\_\_

COMPANY NAME \_\_\_\_\_

TEL No. \_\_\_\_\_

CORGI ID CARD SERIAL No. \_\_\_\_\_

COMMENTS \_\_\_\_\_

SIGNATURE \_\_\_\_\_

## SERVICE 6 DATE \_\_\_\_\_

ENGINEER NAME \_\_\_\_\_

COMPANY NAME \_\_\_\_\_

TEL No. \_\_\_\_\_

CORGI ID CARD SERIAL No. \_\_\_\_\_

COMMENTS \_\_\_\_\_

SIGNATURE \_\_\_\_\_

## SERVICE 7 DATE \_\_\_\_\_

ENGINEER NAME \_\_\_\_\_

COMPANY NAME \_\_\_\_\_

TEL No. \_\_\_\_\_

CORGI ID CARD SERIAL No. \_\_\_\_\_

COMMENTS \_\_\_\_\_

SIGNATURE \_\_\_\_\_

## SERVICE 8 DATE \_\_\_\_\_

ENGINEER NAME \_\_\_\_\_

COMPANY NAME \_\_\_\_\_

TEL No. \_\_\_\_\_

CORGI ID CARD SERIAL No. \_\_\_\_\_

COMMENTS \_\_\_\_\_

SIGNATURE \_\_\_\_\_

## SERVICE 9 DATE \_\_\_\_\_

ENGINEER NAME \_\_\_\_\_

COMPANY NAME \_\_\_\_\_

TEL No. \_\_\_\_\_

CORGI ID CARD SERIAL No. \_\_\_\_\_

COMMENTS \_\_\_\_\_

SIGNATURE \_\_\_\_\_

## SERVICE 10 DATE \_\_\_\_\_

ENGINEER NAME \_\_\_\_\_

COMPANY NAME \_\_\_\_\_

TEL No. \_\_\_\_\_

CORGI ID CARD SERIAL No. \_\_\_\_\_

COMMENTS \_\_\_\_\_

SIGNATURE \_\_\_\_\_

## MANUAL HANDLING OF APPLIANCE PRODUCTS

### Description

Manual handling means any transporting or supporting of a load (including lifting, putting down, pushing, pulling, carrying or moving) by hand or bodily force.

### Scope

This assessment will cover the largest Appliance, namely ElectraMate, GulfStream, BoilerMate, SysteMate, PulsaCoil, Accolade and Stainless Lite manufactured by Gledhill.

The maximum weight of the largest product in each range is 98kg and the size is 595 x 595 x 2020 mm high.

### Main Hazards

Vision may not be clear due to the size of the products. Adopting an incorrect method of lifting may cause injury, attempting to lift these products will require help from others. (Team lifts)

### Control Measures

#### Manual lifting procedure

The lift, key factors in safe lifting are:

- a. **Balance**
  - b. **Position of back**
  - c. **Positioning of the arms and body**
  - d. **The hold**
  - e. **Taking the lead for team lifts**
- a. **Balance** - Since balance depends essentially upon the position of the feet, they should be apart about hip breadth with one foot advanced giving full balance sideways and forward without tension. In taking up this position, lifting is done by bending at the knees instead of the hips and the muscles that are brought into use are those of the thigh and not the back.
  - b. **Position of back** - Straight - not necessary vertical. The spine must be kept rigid, this coupled with a bent knee position, allows the centre line of gravity of the body to be over the weight so reducing strain.
  - c. **Positioning of arms and body** - The further arms are away from the side, the greater the strain on the shoulders, chest and back. Keep elbows close to the body arms should be straight.
  - d. **The hold** - Before lifting ensure you have a good hold. Two handles are provided on Appliance products at the top rear side, these allow one or two persons to have a purposely-designed hold at the top of the appliance to ensure easy lifting at the top of the product. Each appliance is supplied with a pallet, which has been attached to the unit via the packaging. The pallet will also allow for one or two persons to get a good hold.

- e. **Taking the lead for team lifts**- As more than one person is required for these products ensure that one person is taking the lead. **This may be you** so ensure that each person that is helping is made aware of the weight and of the items listed within this assessment. Make sure you and any others helping know the route you intend to take that it is clear of any obstructions. Never jerk the load as this will add a little extra force and can cause severe strain to the arms, back and shoulders. If there are steps involved decide on where you will stop and take a rest period. Move smoothly and in unison taking care to look and listen to others helping with the lift. Where possible use a sack truck to move the product over long flat distances, only lift the products when necessary. If in doubt stop and get more help. The unit handles and packaging with the pallet have been designed to ensure that two-four people can assist when lifting up stairs or over longer distance.

#### Individual capability

Individual capability plays an important part in handling these products. Persons above average build and strength will find it easier and should be in good health. Persons below average build and strength may require more rest periods during the handling process. Pregnant women should not carry out this operation. Persons who are not in good health should seek medical advice prior to commencing any lifting or manual handling operation.

#### Residual risk

Following the guidelines given above will reduce any risk to injury. All persons carrying out this operation must be fully trained and copies of the specific risk assessment made available for inspection and use in their training process.

Further guidance on Manual Handling can be obtained from the Health and Safety Executive. Manual Handling Operations Regulations 1992.

# Gledhill (Water Storage) Ltd

AMD JUNE 2018

## CONDITIONS OF SALE & GUARANTEE TERMS

1. Gledhill (Water Storage) Ltd ("We" or "Gledhill") only the business upon the Conditions which appear below and no other. Unless we so agree in writing these Conditions shall apply in full to any supply of goods by us to the exclusion of any Conditions or terms sought to be imposed by any purchaser. These Conditions of Sale and Warranty Terms override those which are contained on the Invoice Forms and all Sales are made subject to these Conditions of Sale and Warranty Terms only.

### 2. PRICE

Once an order or call off has been accepted the price will be held for three months but if delivery is postponed beyond that period at the customer's request, then we reserve the right to amend the price when necessary. The company reserves its pricing flexibility subject for changes in our cost base. We reserve the right to alter prices at any time for serious shortages in raw materials (notably copper and steel). If there is to be a change we will give customers at least two weeks notice but anything different after that date will be at the market price. An order may not be cancelled or varied after acceptance without the written consent of the company. Such cancellations or variations shall be subject to such acceptable changes as may be appropriate.

### 3. SPECIFICATIONS

The goods are supplied in accordance with the Specifications (if any) submitted to the Purchaser and any additions and alterations shall be the subject of an extra charge. Any goods not so specified shall be in accordance with our printed literature or the literature of any of our component suppliers (subject to any modifications made from publication). If we adopt any change in construction or design of the goods, or in the specifications printed in our literature, the Purchaser shall accept the goods as changed in fulfillment of the order.

### 4. PAYMENT

The Invoice price of goods shall be payable within 30 days of dispatch by us of our Invoice for the goods or such longer time as may be stated by our quotation or invoice. If we receive payment in full or before the due date we will allow an appropriate settlement discount except where we have quoted a special net price. If payment is not received in full over the due date we shall be entitled in addition to the Invoice price to:

- (i) payment of a sum equal to any increase in the copper price supplement applicable to the particular goods sold between the date of receipt of order and the date of receipt of payment in full; and
- (ii) interest on any part of the Invoice price unpaid after the due date at the rate of 3% per annum over the base rate for the time being of HSBC Bank plc.

### 5. TIME

We give estimates of delivery dates in good faith and time of delivery is not set shall be made within the scope of any contract nor shall we be liable for any loss or damage occasioned by delay in delivery.

### 6. DELIVERY

We deliver normally by our own vehicles within 25 miles of any of our manufacturing depots. Delivery to any place more than 25 miles from one of our manufacturing depots may be subject to our special delivery charges. We reserve the right to make delivery of goods contained in one order by more than one consignment and at different times. Where a period is agreed for delivery and such period is not observed by our Agreement, the Purchaser shall take delivery without delay. If the Purchaser fails to take delivery, we shall be entitled at the Purchaser's risk and expense to store the goods at the Purchaser's premises or elsewhere and to demand payment as if they had been despatched. Off loading at point of delivery shall be the responsibility of and be undertaken by the Purchaser.

### 7. INSPECTION OR DAMAGE

Goods must be inspected before dispatch of delivery note and any damage, short age or discrepancy noted on the delivery note and the goods returned on the same vehicle. The buyer must also give us immediate notification of the damage, shortage or discrepancy so that we may prompt investigation.

### 8. RETURN OF GOODS

Goods may not be returned to the Company except by prior written permission of an authorized officer of the Company and such return shall be subject to payment by the Purchaser of handling and re-stocking charges, transport and other costs incurred by the Company.

### 9. COMPANY LIABILITY AND GUARANTEE

9.1. Subject to the terms of these Conditions of Sale and the section Three Excluded Products Guarantee in respect of specific products as set out in this clause.

9.2. Each Guarantee is strictly conditioned upon the following:

9.2.1. Complaints must be given to us immediately, before any action is taken, as responsibility cannot be accepted if repairs or services are attempted on site without our written approval.

9.2.2. The unit has been installed in accordance with our installation and service instructions and all relevant codes of practice and regulations in force at the time of installation.

9.2.3. All relevant inlet controls and safety valves have been fitted correctly.

9.2.4. The unit has only been used for the storage of potable water supplied from the public mains.

9.2.5. Where appropriate the unit has been regularly maintained as detailed in the installation and service instructions.

9.2.6. Defects caused by corrosion or scale deposits are not covered by any Guarantee.

9.2.7. Where we agree to rectify any defect we reserve the right to undertake the work on our own premises.

9.3. Guarantees are provided in respect of specified goods supplied by Gledhill as follows:

(a) Domestic and Commercial Direct Venting Cylinders and Tanks.

The copper storage vessel is guaranteed for ten years and if it proves to be defective either in materials or workmanship, we will either repair or supply replacement at our option with the direct substitute in the case of any obsolete product to any address in Great Britain.

(i) Free of all charge during the first year after delivery by us.

(ii) Thereafter at a charge of one-third of the then current list price and any copper price supplement and delivery charge during the second year after delivery by us and increasing by a further one-third on the second and subsequent anniversary of delivery by us.

(a) Domestic Direct Vent Products (Primary System)

The copper storage vessel is guaranteed for five years and if it or any integral pipework as part of the storage vessel assembly proves to be defective either in materials or workmanship, we reserve the right to either repair or supply replacement as the closest possible substitute in the case of any obsolete product and will collect and deliver to any address in England, Wales and Scotland (excluding all Scottish islands).

(i) Free of all charge during the first year after delivery by us.

(ii) Thereafter at a charge of one-third of the then current list price or any copper price supplement and delivery charge during the second year after delivery by us increasing by a further one-third on the second and subsequent anniversary of delivery by us.

(a) Integrated Boiler and Storage Tank Products and Stand Alone Boilers

In the case of the Gledhill range of products and the Eledhill other range of products, Gledhill guarantees the heat exchanger (boiler) for material and construction faults for two years. THE RESPONSIBILITY FOR THE EXECUTION OF THE GUARANTEE LIES WITH THE INSTALLER.

The guarantee becomes null and void if the appliance is used incorrectly, or in the event of power negligence or incorrectly implemented repairs OR FAILURE TO CLADY BUT THE RECOMMENDED MAINTENANCE. The guarantee also becomes null and void if changes are made to the appliance without our knowledge, or if the serial number on the appliance is removed or made illegible.

The annual service must be carried out by a competent installer in accordance with the advice given by Gledhill and using Gledhill approved parts.

(a) Industrial Direct Venting Cylinders

Gledhill guarantees the components including controls, valves and electrical parts for two years from the date of purchase. IT SHOULD BE NOTED THAT THE FACTORY FITTED TEMPERATURE AND PRESSURE RELIEF VALVE MUST NOT BE REMOVED OR ADJUSTED IN ANY WAY OR THE GUARANTEE WILL NOT BE VALID. GLEDHILL WILL NOT BE RESPONSIBLE FOR ANY CONSEQUENTIAL LOSS OR DAMAGE HOWSOEVER IT IS CAUSED.

The guarantee for the stainless steel vessel is for twenty five years if the original unit is returned to us AND PROVIDED THAT:

(i) It has been installed as per the Design, Installation & Servicing Instructions, relevant standards, regulations and codes of practice.

(ii) It has not been modified, other than by Gledhill.

(iii) It has not been subjected to wrong or improper use or ill treatment.

(iv) It has only been used for the storage of potable water.

(v) It has not been subjected to fire damage.

(vi) The benchmark log book is completed after each annual service.

(vii) The unit has been serviced annually.

It should be noted that the guarantee does not cover:

- the effects of scale build up

- any labour charges associated with replacing the unit or parts.

If the stainless steel vessel proves to be defective either in materials or workmanship we reserve the right to either repair or supply replacements or the closest possible substitute in the case of any obsolete product and will collect and deliver to any address in England, Scotland and Wales (excluding all islands).

(i) Free of charge during the first year after delivery by us.

(ii) Thereafter at a charge of one-third of the then current list price during the second year after delivery by us and increasing by a further one-third on the second and subsequent anniversary of delivery by us.

### ACTION IN THE EVENT OF FAILURE

If the stainless steel cylinder develops a leak we will either a deposit against the supply of a new one. This will be refunded if it fails to within the time of the warranty when it has been accepted by us.

(a) Boiler Products and ancillary equipment

Gledhill provides a five year warranty for faults in the collector (except frost damage and collector accessories eg metal cladding). If the collector demonstrably fails to meet one of the requirements of the standard BS1457 part 3 we will replace it free of charge based on the date of issue. We can not be responsible for damage caused by mechanical stress and/or charges caused by weather related influences. The warranty excludes other surface damage that does not affect performance or satisfaction due to improper assembly or installation.

### Please note

- Installation work must have been carried out by a licensed specialist company (installing contractor or plumber) following the version of installation instructions in force.

- Gledhill or its representative has given the opportunity to check compliance on site immediately after any defect occurred.

- Confirmation exists that the system was commissioned properly and that the system was checked and maintenance was performed annually by a specialist company licensed for this purpose.

(a) Components of our products other than Storage Vessels and Integral Pipework

We will either refund to the purchaser the same terms of warranty as we are given by the manufacturer of the component or if the manufacturer does not give any warranty, replace free of charge any component which becomes defective within five years after the date of the delivery by us and is returned to us at the purchaser's expense but we shall not be liable for the cost of removal or shipping or return of the component or any other cost charge or damage incurred by the purchaser.

If the appliance manufactured by Gledhill incorporates a factory fitted scale inhibitor then during the period



of five years from the date of delivery. Goodwill will replace, free of charge, any photo local end-user fitted in the appliance as original equipment in which to call the same then occur that substantially reduces the effectiveness of the photo local mechanism. This guarantee does not extend to any other component installed within the Goodwill appliance or elsewhere in the Purchaser's domestic water system.

**9A.**

**9A.1.** In respect of goods supplied by us and in respect of any installation work carried out by us or our staff, our entire liability and the purchaser's sole remedy (subject to the Guarantee) shall be as follows:-

- (a) We accept liability for death or personal injury to the extent that it results from our negligence or that of our employees.
- (b) Subject to the other provisions of this clause 9 we accept liability for direct physical damage to tangible property to the extent that such damage is caused by our negligence or that of our employees, agents or subcontractors.
- (c) Our total liability to the purchaser over and above any liability to replace under the Guarantee (whether in contract or tort including negligence) in respect of any one cause of loss or damage claimed to result from any breach of our obligations hereunder, shall be limited to actual money damages which shall not exceed £20,000 provided that such monetary limit shall not apply to any liability on the part of ourselves in respect to paragraph (a) above.
- (d) Except as provided in paragraph (a) above but otherwise not withstanding any provision herein contained in no event shall we be liable for the following loss or damage, however caused and even if same results by us or in our contemplation:-
  - (i) economic loss which shall include loss of profits, business revenue, goodwill or anticipated savings.
  - (ii) damages in respect of special interest or consequential loss or damage (other than death, personal injury and damage to tangible property)
  - (iii) any claim made against the purchaser by any other party (save as expressly provided in paragraph (b) above)
- (e) Except in respect of our liability referred to in paragraph (c) above no claim may be made or action brought (whether in contract or in tort including negligence) by the purchaser in respect of any goods supplied by us more than one year after the date of the installation of the relevant goods.
- (f) Without prejudice to any other term we shall not be liable for any water damage caused directly or indirectly as a result of any leak or other defect in the goods. We cannot control the conditions of use of the goods or the time or manner or location in which they will be installed and the purchaser agrees to be fully responsible for testing and checking all units which include the goods at all relevant times (pre, during and after commissioning) and for taking all necessary steps to identify any leaks and prevent any damage being caused thereby.
- (g) Nothing in these Conditions shall confer on the purchaser any rights or remedies to which the purchaser would not otherwise be legally entitled.

**10. LOSS OF EARNINGS**

Notwithstanding any other provision contained herein the purchaser's liability agrees to fully indemnify us against any damage, losses costs claims or expenses incurred by us in respect of any claim brought against us by any third party for:-

- (a) any loss injury or damage wholly or partly caused by any goods supplied by us or their use.
- (b) any loss injury or damage wholly or partly caused by the defective installation or substandard workmanship or materials used in the installation of any goods supplied by us.
- (c) any loss injury or damage in any way connected with the performance of this contract.
- (d) any loss resulting from any failure by the purchaser to comply with its obligations under these terms as to install and/or check, vents correctly.

**PROVIDED** that this paragraph will not require the purchaser to indemnify us against any liability for our own acts of negligence or those of our employees or agents or sub-contractors.

**FURTHER** in the case of goods supplied by us which are re-sold and installed by a third party by the purchaser it will be the sole responsibility of the purchaser to test the goods immediately after their installation to ensure that later alterations are correctly installed and in preventing water from leaks and are not likely to cause any loss injury or damage to any person or property.

**11. VARIATION OF REMEDY AND EXCLUSIONS**

Should our warranty and exclusion be unacceptable we are prepared to negotiate for variation in their terms but only on the basis of an increase in the price to allow for any additional liability or risk which may result from the variation.

Purchaser are advised to insure against any risk or liability which they may incur and which is not covered by our warranty.

**12. RELEASED RETENTION OF TITLE**

- (a) Goods supplied by us shall be at the Purchaser's risk immediately upon delivery in the Purchaser or into custody on the Purchaser's behalf or in the Purchaser's Debit. The Purchaser shall warrant adequate insurance of the goods against all risks in the full invoice value of the goods, such insurance to be effective from the time of delivery until property in the goods shall pass to the Purchaser as hereinafter provided.
- (b) Property in the goods supplied hereunder will pass to the Purchaser when full payment has been made by the Purchaser to us for:-
  - (i) the goods of the subject of this contract.
  - (ii) all other goods the subject of any other contract between the Purchaser and us which, at the time of payment of the full price of the goods sold under this contract, have been delivered to the Purchaser but not paid for in full.
- (c) until property in the goods supplied hereunder passes to the Purchaser in accordance with paragraph (b) above.
  - (i) the Purchaser shall hold the goods in a fiduciary capacity for us and shall store the same separately from any other goods in the Purchaser's possession and in a manner which enables them to be identified as our goods.
  - (ii) the Purchaser or all persons liable under this contract to us shall owe a fiduciary obligation as required. All the necessary incidents associated with a fiduciary relationship shall apply.
- (d) the Purchaser's right to possess the goods shall cease forthwith upon the happening of any of the following events, namely:-
  - (i) if the Purchaser fails to make payment in full for the goods within the time stipulated in clause 4 hereof.
  - (ii) if the Purchaser, not being a company, commits any act of bankruptcy, makes a proposal in its or her capacity for a composition or does anything which would entitle a petition for a Bankruptcy Order to be presented.
  - (iii) if the Purchaser, being a company, does anything or fails to do anything which would entitle an administrator or an administrative receiver or a receiver to take possession of any assets or which would entitle any person to present a petition for winding up or to apply for an administration order.
- (e) the Purchaser hereby grants to us an irrevocable licence to enter at any time any vehicle or premises owned or occupied by the Purchaser or in the possession of the Purchaser for the purpose of repossessing and

recovering any such goods the property in which has been lost in or under paragraph (2) above. We shall not be responsible for and the Purchaser will indemnify us against liability in respect of damage caused to any vehicle or premises in such repossession and removal being damaged which it was not reasonably practicable to avoid.

(f)

Notwithstanding paragraph (e) hereof and subject to paragraph (7) hereof, the Purchaser shall be permitted to sell the goods to third parties in the normal course of business. In this regard the Purchaser shall act in the capacity of our commission agent and the proceeds of such sale:-

(i) shall be held in trust for us in a manner which enables such proceeds to be identified as such, and;

(ii) shall not be mixed with our monies nor paid into an overdraw bank account.

We, as principal, shall reimburse the Purchaser as commission agent a commission depending upon the surplus which the Purchaser can obtain over and above the sum, stipulated in this contract of supply which is available to us.

(g)

In the event that the Purchaser shall sell any of the goods provided to clause (a) hereof, the Purchaser shall forthwith inform us in writing of such sale and of the identity and address of the third party to whom the goods have been sold.

(h)

If, before property in the goods passes to the Purchaser under paragraph (2) above the goods are or become attached to any land or building owned by the Purchaser it is hereby agreed and declared that such attachment shall not have the effect of passing property in the goods to the Purchaser. Furthermore if, before property in the goods shall pass to the Purchaser under paragraph (2) hereof, the goods are or become attached to any land or building (whether or not owned by the Purchaser), the Purchaser shall:-

(i) ensure that the goods are capable of being removed without material injury to such land or building.

(ii) take all necessary steps to prevent title to the goods from passing to the trustee of such land or building.

(iii) forthwith inform us in writing of such attachment and of the address of the land or building concerned.

The Purchaser warrants to repair and make good any damage caused by the attachment of the goods to or their removal from any land or building and to indemnify us against all loss damage or liability we may incur or sustain as a result of attachment or removal.

(i) In the event that, before property in the goods has passed to the Purchaser under paragraph (2) hereof, the goods or any of them are lost, stolen, damaged or destroyed:-

(ii) the Purchaser shall forthwith inform us in writing of the fact and circumstances of such loss, theft, damage or destruction.

(iii) the Purchaser shall assign to us the benefit of any insurance claims in respect of the goods so lost, stolen, damaged or destroyed.

**13. NON-PAYMENT**

If the Purchaser shall fail to make full payment for the goods supplied hereunder within the time stipulated in clause 4 hereof or to in default of payment for any other reason then, without prejudice to any of our other rights hereunder, we shall be entitled to stop all deliveries of goods and materials to the Purchaser, including deliveries or further deliveries of goods under this contract. In addition we shall be entitled to demand all outstanding monies.

**14. UNLAWFUL TAX**

All prices quoted are exclusive of Value Added Tax which will be charged at the rate ruling at the date of dispatch of goods.

**15. WHOLESALE ONLY**

We are only prepared to deal with those who are not consumers within the terms of the Unfair Contract Terms Act 1977, the Sale of Goods Act 1979 and the Supply of Goods and Services Act 1982. Accordingly any person who purchases from us should be deemed to have represented that he is not a consumer by so purchasing.

**16. JURISDICTION**

This agreement is subject to English law for products delivered in England and Scottish law for products delivered in Scotland and any dispute hereunder shall be settled in accordance therewith dependent upon the location.

