

A-CLASS

BoilerMate SP

DESIGN, INSTALLATION AND SERVICING INSTRUCTIONS

Gas Council Approved Reference Numbers

89-317-14 / BMA 120 SP
89-317-15 / BMA 140 SP
89-317-16 / BMA 180 SP
89-317-17 / BMA 200 SP
89-317-18 / BMA 220 SP



*The code of practice for the installation,
commissioning & servicing of central heating systems*

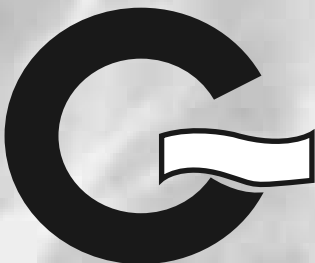

**A SEALED CENTRAL HEATING
AND MAINS PRESSURE HOT WATER SUPPLY
SYSTEM INCORPORATING
A THERMAL STORE**

**ALL MODELS COMPLY WITH THE
WATER HEATER MANUFACTURERS
SPECIFICATION FOR INTEGRATED THERMAL
STORES**

CONTENTS

ISSUE 6: 06-08



*The code of practice for the installation,
commissioning & servicing of central heating systems*

Building Regulations and Benchmark Commissioning

The Building Regulations (England & Wales) require that the installation of a heating appliance be notified to the relevant Local Authority Building Control Department. From 1st April 2005 this can be achieved via a Competent Person Self Certification Scheme as an option to notifying the Local Authority directly. Similar arrangements will follow for Scotland and will apply in Northern Ireland from 1st January 06.

CORGI operates a Self Certification Scheme for gas heating appliances.

These arrangements represent a change from the situation whereby compliance with the Building Regulations was accepted if the Benchmark Logbook was completed and this was then left on site with the customer).

With the introduction of a self certification scheme, the Benchmark Logbook is being replaced by a similar document in the form of a commissioning check list and a service interval record is included with all gas appliance manuals. However, the relevant Benchmark Logbook is still being included with all Thermal Storage products and unvented cylinders.

Gledhill fully supports the Benchmark aims to improve the standards of installation and commissioning of central heating systems in the UK and to encourage the regular servicing of all central heating systems to ensure safety and efficiency.

Building Regulations require that the heating installation should comply with the manufacturer's instructions. It is therefore important that the commissioning check list is completed by the competent installer. This check list only applies to installations in dwellings or some related structures.

Section	Page
1.0 DESIGN	
1.1 Introduction	3
1.2 Technical Data	5
1.3 System Details	13
2.0 INSTALLATION	
2.1 Site Requirements	20
2.2 Installation	21
2.3 Commissioning	31
3.0 SERVICING	
3.1 Annual Servicing	35
3.2 Changing Components	35
3.3 Short Parts List	36
3.4 Fault Finding	37
Appendix A	38
Appendix B	39
Appendix C	42
Appendix D	43
Terms & Conditions	44

The Gledhill BoilerMate range is a WBS listed product and complies with the WMA Specification for integrated thermal storage products. The principle was developed in conjunction with British Gas. This product is manufactured under an ISO 9001:2000 Quality System audited by BSI.

Patents Pending

The Gledhill Group's first priority is to give a high quality service to our customers.

Quality is built into every Gledhill product and we hope you get satisfactory service from Gledhill.

If not please let us know.

1.1 INTRODUCTION

These instructions should be read in conjunction with the Installation and Servicing Instructions issued by the manufacturers of the heat source e.g. the boiler used.

Any water distribution and central heating installation must comply with the relevant recommendations of the current version of the Regulations and British Standards listed below:-

Gas Safety Regulations
Building Regulations
I.E.E. Requirements for Electrical Installations
Water Regulations

British Standards

BS6798, BS5449, BS5546, BS5440:1, BS5440:2, CP331:3, BS6700, BS5258, BS7593 and BS7671.

A suitably competent person as stated in the Gas Safety Regulations must install the BoilerMate and carry out any subsequent maintenance/repairs. In fact, the front panel is secured by 2 screws and should only be removed by a competent trades person. The manufacturer's notes must not be taken as overriding statutory obligations.

The BoilerMate A-Class SP is only suitable for use with a sealed primary central heating system.

The BoilerMate A-Class is not covered by section G3 of the current Building Regulations and is therefore not notifiable to Building Control.

The BoilerMate A-Class SP is not intended for use by persons (including children) with reduced physical, sensory or mental capabilities, or lack of experience or knowledge, unless they have been given supervision or instruction concerning use of the appliance by a person responsible for their safety.

Children should be supervised to ensure that they do not play with the appliance.

The information in this manual is provided to assist generally in the selection of equipment. The responsibility for the selection and specification of the equipment must however remain that of the customer and any Designers or Consultants concerned with the design and installation.

Please Note: We do not therefore accept any responsibility for matters of design, selection or specification or for the effectiveness of an installation containing one of our products unless we have been specifically requested to do so.

All goods are sold subject to our Conditions of Sale and Warranty Terms, which are set out at the rear of this manual.

In the interest of continuously improving the BoilerMate range, Gledhill Water Storage Ltd reserve the right to modify the product without notice, and in these circumstances this document, which is accurate at the time of printing, should be disregarded. It will however be updated as soon as possible after the change has occurred.

Description

The BoilerMate A-Class SP shown schematically on page 4 is designed to provide sealed system space heating and mains pressure hot water at high flow rates when coupled to any remotely sited, condensing or non condensing, boiler suitable for sealed heating systems, as long as they comply with the recommendations contained in the rest of this manual.

The BoilerMate A-Class is an indirectly heated hot water only thermal store and is supplied with the factory fitted controls and equipment shown in Section 1.2 Technical Data. The indirect heat exchanger is highly efficient and designed to provide extremely quick hot water recovery as well as back-up space heating when using 'Switch'.

Because the F & E cistern is only used to fill the thermal store the standard appliance is supplied as a manual fill model, i.e., without a ballvalve and overflow, which makes it particularly suitable for use in flats/apartments. A ballvalve and overflow fitting can be supplied as an optional extra if required to provide an automatic fill model.

Because this product does not require a safety discharge from a temperature and pressure relief valve, any installations will be easy to incorporate into the building and will not suffer from the problems associated with using PVCu soil stacks to take the discharge from unvented cylinders.

An important feature of this concept is that hot water can be supplied directly from the mains at conventional flow rates without the need for temperature and pressure relief safety valves or expansion vessels. This is achieved by passing the mains water through a plate heat exchanger. The outlet temperature of the domestic hot water is maintained by a printed circuit board (A.C.B.), which controls the speed of the pump circulating the primary water from the store through the plate heat exchanger.

1.1 INTRODUCTION

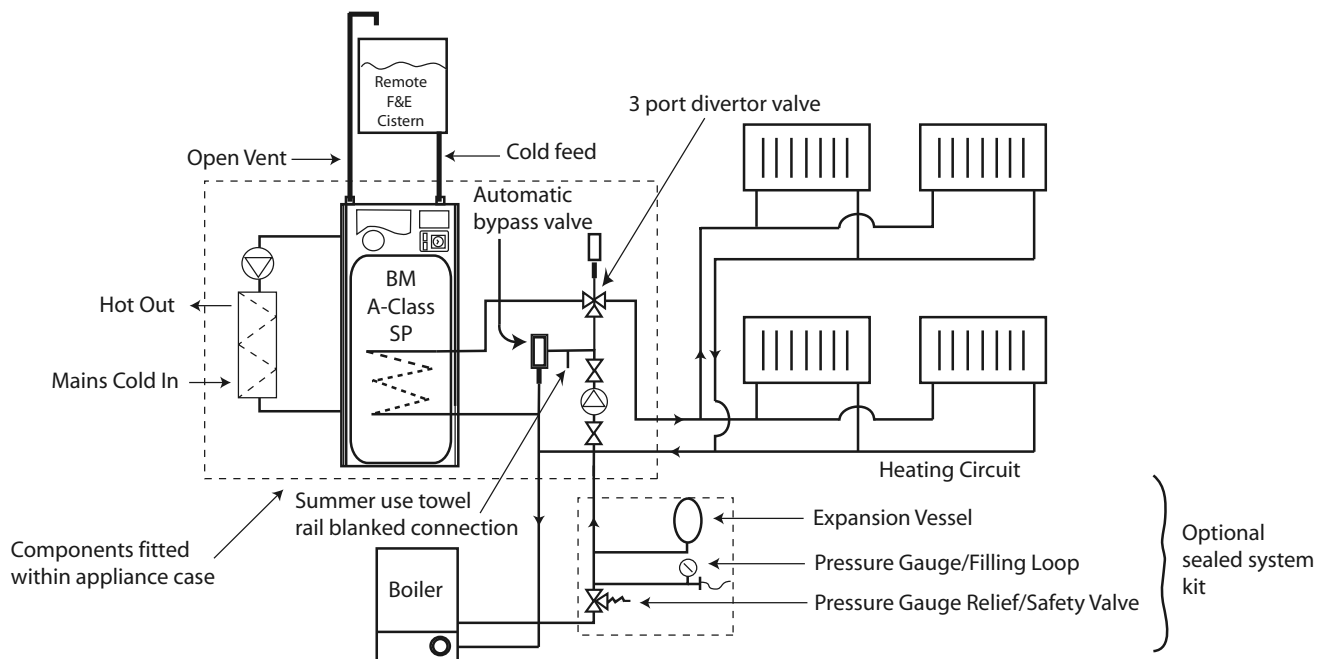

The Building Regulations L1A: New dwellings/L1B: Existing dwellings and the requirements set out in the Domestic Heating Compliance Guide specify that “where the mains water hardness exceeds 200ppm provision should be made to treat the feed water to water heaters and the hot water circuit of combination boilers to reduce the rate of accumulation of lime scale”.

To comply with this requirement the hardness of the mains water should be checked by the installer and if necessary the optional factory fitted in-line scale inhibitor should be specified at the time of order for hardness levels between 200 and 300 ppm (mg/l).

Where the water is very hard ie 300ppm (mg/l) and above the optional polyphosphate type, inhibitor should be specified at the time of order. However, this will need to be fitted by the installer at a suitable point in the cold water supply to the appliance.

If scale should ever become a problem the plate heat exchanger is easily isolated and quickly replaced with a service exchange unit which can be obtained at a nominal cost from Gledhill.

The A.C.B. also incorporates the facility to operate the primary pump for a few seconds every few days when the heating is not being used (to reduce the likelihood of the pumps sticking) as well as providing a primary pump overrun facility for the boiler.

Any sealed system automatic boiler designed to operate on an 82°C flow and a 71°C return up to a maximum of 35kW can be linked to any suitable model of BoilerMate A-Class and the deciding factor is the space heating and the hot water requirements of a dwelling. See Section 1.2 Technical Data for further details.

The BoilerMate A-Class is supplied complete with ‘Switch’ which will provide a 6kW electrical emergency backup in case of failure of the main heat source. See section 1.3 System Details for further information.

The heat losses from thermal stores should not be directly compared with heat losses

from unvented or vented cylinders because they are treated differently in SAP. The SAP calculator takes account of the type of store and various correction factors are included to reflect the different ways that the hot water and heating operates.

For further information please request a copy of the SAP 2005 Data Sheet which provides the information required to produce SAP calculations for all Gledhill Thermal Storage products.

Gledhill are part of the ‘Benchmark’ scheme and a separate commissioning/service log book is included with the product.

A 15mm connection is provided on the primary return on all units to allow for the provision of a pumped summer use towel rail circuit if required (see page 16 for further details)

Note -The BoilerMate SP is a SYSTEM appliance and only requires a basic boiler without a pump. If a system boiler is chosen this will present wiring/operational difficulties as well as incurring extra cost

1.0 DESIGN

1.2 TECHNICAL DATA

Model	BMA 120 SP	BMA 140 SP	BMA 180 SP	BMA 200 SP	BMA 220 SP
Weight (empty)	49.4 kg	51.8 kg	54.2 kg	56.5 kg	60.8 kg
Weight (full)	174.4 kg	191.3 kg	201.2 kg	220.5 kg	245.8 kg
DHW Pump	Grundfos UPR 15/50	Grundfos UPR 15/50	Grundfos UPR 15/50	Grundfos UPR 15/50	Grundfos UPR 15/50
Boiler/Heating Pump	Grundfos UPS 15/50	Grundfos UPS 15/50	Grundfos UPS 15/50	Grundfos UPS 15/60	Grundfos UPS 15/60
Primary/heating pipe connections	22mm	22mm	22mm	28mm	28mm
MCW & DHW pipe connections	22mm	22mm	22mm	22mm	22mm
Cold feed/expansion connection	22mm	22mm	22mm	22mm	22mm
Safety open vent connection	22mm	22mm	22mm	22mm	22mm
Primary flow (for summer use bathroom towel rail)	15mm	15mm	15mm	15mm	15mm
Maximum summer towel rail load	0.5kW	0.75kW	1.00kW	1.25 kW	1.5 kW
Maximum pressure heating circuit	3 bar	3 bar	3 bar	3 bar	3 bar
Volume of primary coil	4.9 litres	4.9 litres	5.5 litres	5.5 litres	6.1 litres
Expansion vessel size	12 lts	12 lts	12 lts	25 lts	25 lts
Drain connection	R ½"	R ½"	R ½"	R ½"	R ½"
Maximum Head Thermal Store	6 meters	6 meters	6 meters	6 meters	6 meters
Hot water flow rate (l/m) up to	35	35	35	35	35
Max heating system size	11.25 kW	15 kW	18.75 kW	22.5 kW	26.25 kW
'Switch'	6 kW	6 kW	6 kW	6 kW	6 kW
Typical Dwelling Types					
Bedrooms	1-3	2-3	2-4	3-5	4-6
Bathrooms	1	1	2	1 2	1 2
En-suite shower	1	2	1	4 2	4 3

Notes:-

- The BoilerMate 225 appliance is suitable for use in large properties because it produces the same 'peak hour output' as a typical 350-400 litre unvented cylinder. For properties requiring the BMA 220 the incoming main should be a minimum of 32mm MDPE with a pressure of not less than 2 bar dynamic and an adequate flow in line with the pipe sizing calculations. In many cases, properties of this size will benefit from having 2 smaller sized appliances located adjacent to the areas of peak hot water use. This will allow 2 heating zones to be provided and remove the need to provide trace heating on the hot water system.
- A plastic feed and expansion cistern will be supplied separately including ballvalve, float and overflow fitting.
- The flow rates are based on a 35°C temperature rise and assume normal pressure and adequate flow to the appliance. The actual flow rate from the appliance is automatically regulated to a maximum of 28 litres/min.
- Unit is supplied on a 100mm high installation base.
- The domestic hot water outlet temperature is automatically regulated to approximately 52°C at the bath flow rate of 18 litres/min recommended by BS 6700. The temperature is not user adjustable.
- The designer/installer MUST calculate the suitability of the standard pump as part of normal design procedures.
- The expansion vessel sizes have been calculated to be adequate for typical steel panel mini bore heating systems. The designer/installer MUST check that these are adequate as part of normal design procedures and specify an extra expansion vessel if required.

1.0 DESIGN

1.2 TECHNICAL DATA

Standard Equipment

The standard configuration of the BoilerMate A-Class SP is shown opposite. The Appliance Control Board (A.C.B.), mounted inside the appliance, controls the operation of the complete system. The A.C.B. is pre-wired to a terminal strip where all electrical connections terminate. It is supplied with the following factory fitted equipment:-

1. Boiler/heating pump
2. Domestic hot water primary (plate heat exchanger) pump - modulating
3. 3 port control valve
4. Appliance control board (A.C.B.)
5. Electro-mechanical clock and hot water and space heating control rockers.
6. Plate heat exchanger
7. DHWS temperature sensor
8. Cold water inlet sensor
9. Store temperature sensors
10. Overheat sensor
11. Y type strainer/flow regulator
12. A feed and expansion cistern for filling the thermal store complete with cold feed/open vent pipework assembly is supplied separately.
13. 'Switch' elements (2 x 3 kW)

Optional Equipment

- * A seven day digital clock/programmer to control the space heating (in conjunction with a room thermostat)
- * A no clock/multi-zone option.
- * Hot and cold water manifolds for use with plastic pipework.
- * Scale inhibitor for mains water services with hardness levels above 200ppm (mg/l)
- * Ballvalve/overflow connector for automatic fill model.
- * Primary sealed system kit for fitting near boiler comprising:
 - Expansion vessel (size varies with model of appliance)
 - 15mm 3 bar pressure relief (safety) valve
 - Pressure gauge and filling loop.

12 (F & E Tank not shown)

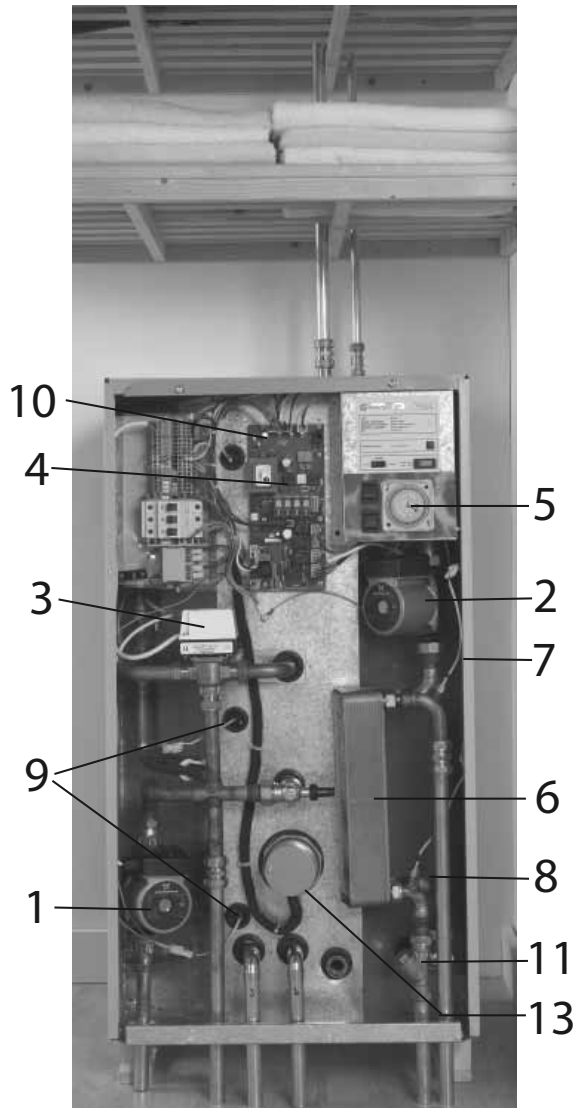

Digital clock programmer



Electro-mechanical clock programmer

1.0 DESIGN

1.2 TECHNICAL DATA

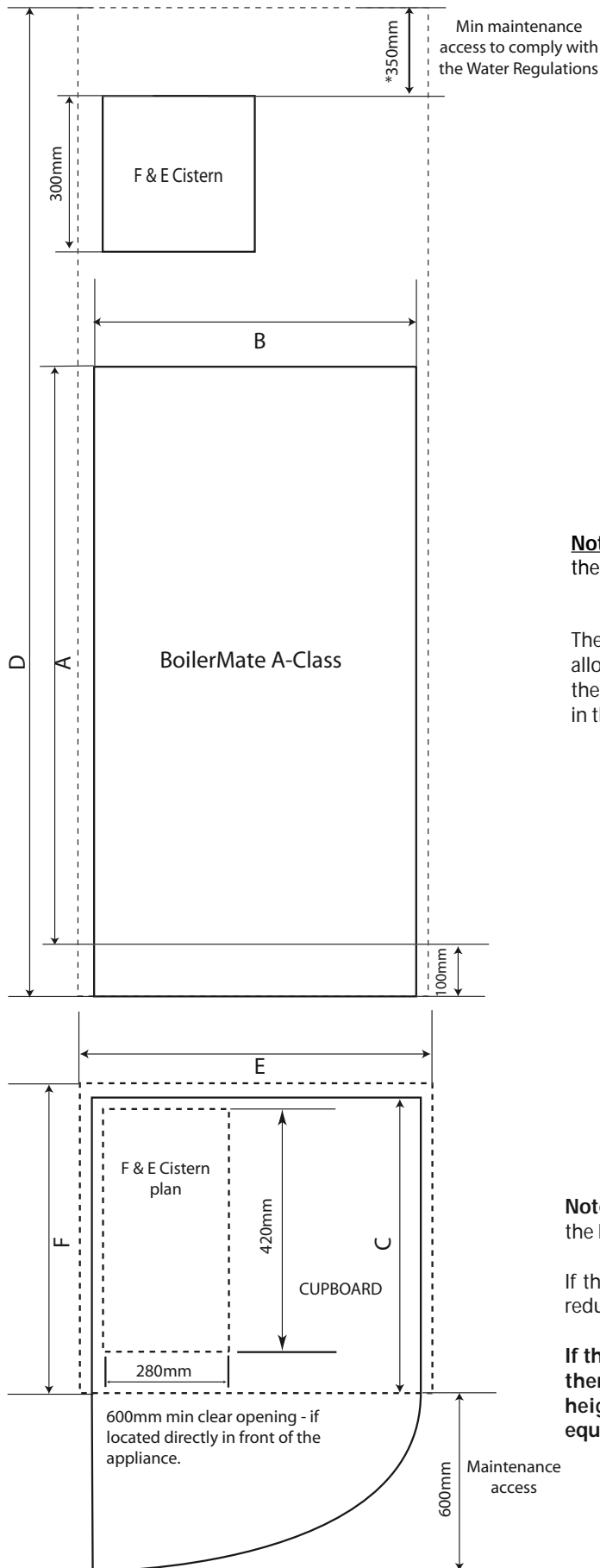

APPLIANCE DIMENSIONS			
MODEL	Height	Width	Depth
	A	B	C
BMA 120 SP	960mm	530mm	595mm
BMA 140 SP	1000mm	530mm	595mm
BMA 180 SP	1040mm	530mm	595mm
BMA 200 SP	1145mm	530mm	595mm
BMA 220 SP	1300mm	530mm	595mm

Note: The Appliance dimensions above do not allow for the 100mm high installation base

The following table of minimum cupboard dimensions only allow the minimum space required for the appliance (including the F & E cistern) and any extra space required for shelving etc in the case of airing cupboards etc must be added.

MINIMUM CUPBOARD DIMENSIONS			
MODEL	Height	Width	Depth
	D	E	F
BMA 120 SP	1710mm	630mm	600mm
BMA 140 SP	1750mm	630mm	600mm
BMA 180 SP	1790mm	630mm	600mm
BMA 200 SP	1895mm	630mm	600mm
BMA 220 SP	2050mm	630mm	600mm

Note: The above dimensions are based on the Appliance and the F & E cistern being in the same cupboard.

If the standard manual fill model is chosen the height can be reduced by 100mm.

If the appliance is to be connected to a multi-zone heating then an additional 150mm must be added to the above heights to accommodate the space required for the zone equipment eg valves.

1.0 DESIGN

1.2 TECHNICAL DATA

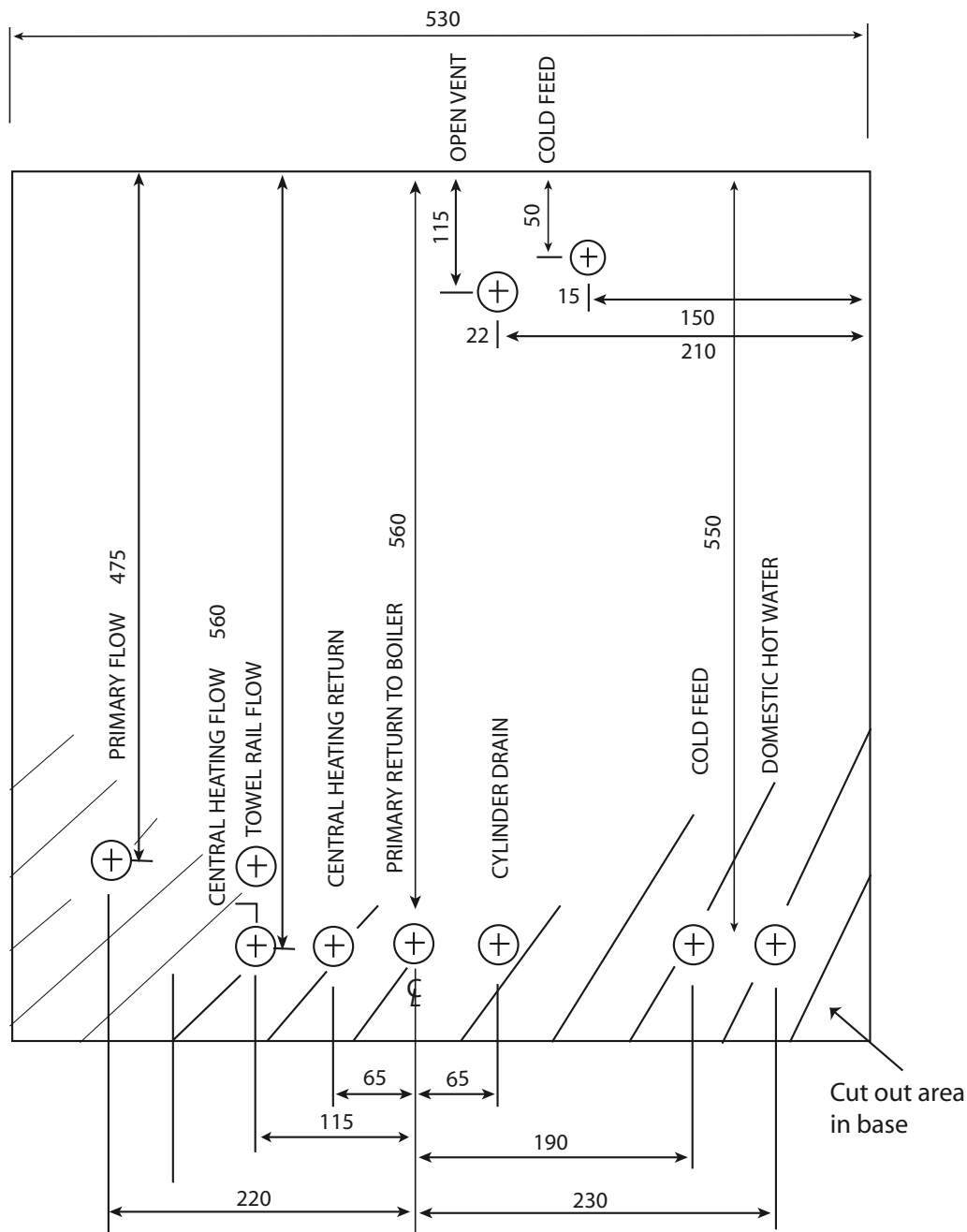

All dimensions in mm - to centre line of pipework

The BoilerMate A-Class units are supplied on an installation base to allow the pipe runs to connect to the appliance from any direction. It is easier if all pipes protrude vertically in the cut out area shown. Compression or push fit connections can be used. All pipe positions are approximate and subject to a tolerance of +/-20mm in any direction. With the standard appliance (supplied without a ballvalve and overflow) a 15mm valved mains cold branch should be provided along with a temporary hose connection incorporating a double check valve to allow the cistern to be easily topped up when necessary (the temporary hose connection must be disconnected once the appliance is filled). With the automatic fill model a 15mm cold water supply and a 22mm warning/overflow pipe will be required for the separate feed and expansion tank.

1.0 DESIGN

1.2 TECHNICAL DATA

Primary heat exchanger (i.e. coil) pressure loss of BoilerMate A-Class

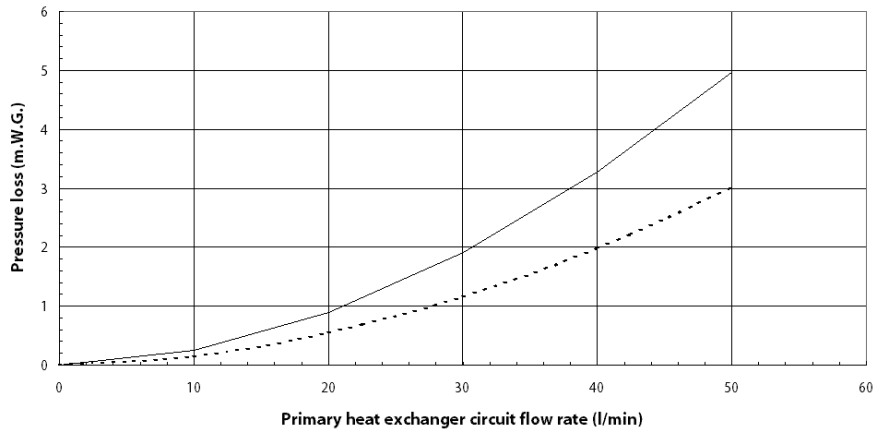

Heating circuit pressure loss of BoilerMate A-Class

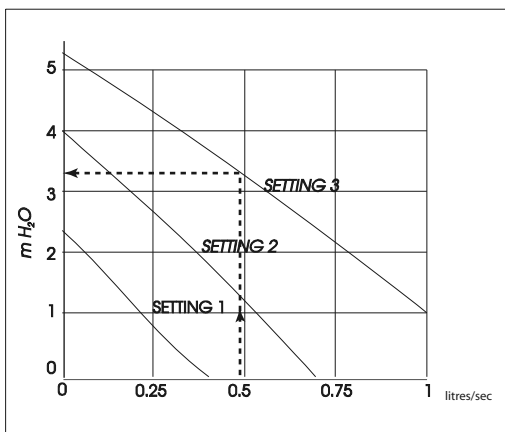
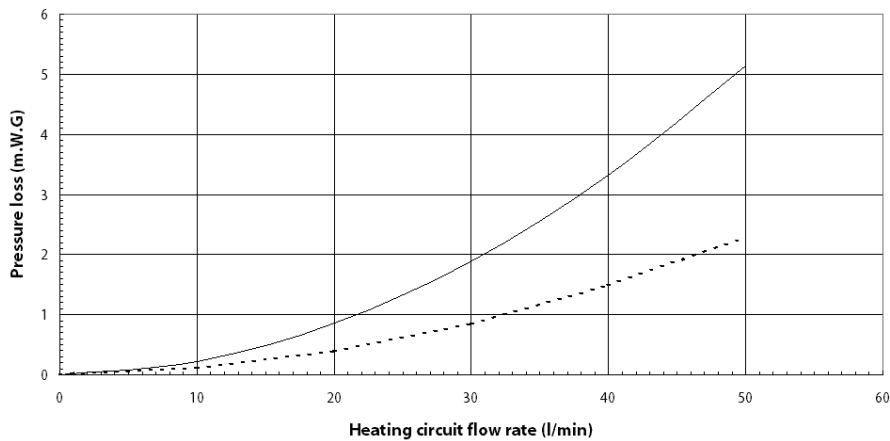

GRUNDFOS 15/50

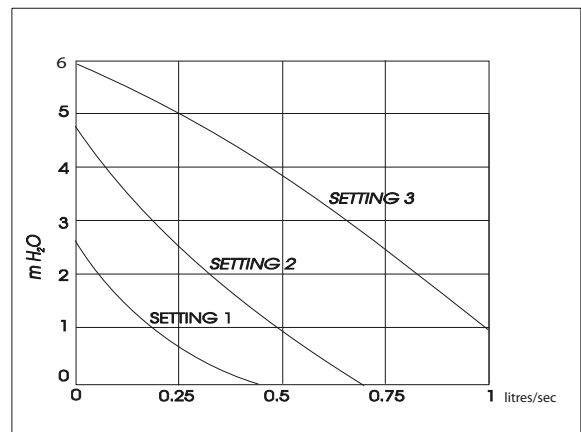

GRUNDFOS 15/60

PERFORMANCE GRAPHS OF GRUNDFOS PUMPS

1.0 DESIGN

1.2 TECHNICAL DATA

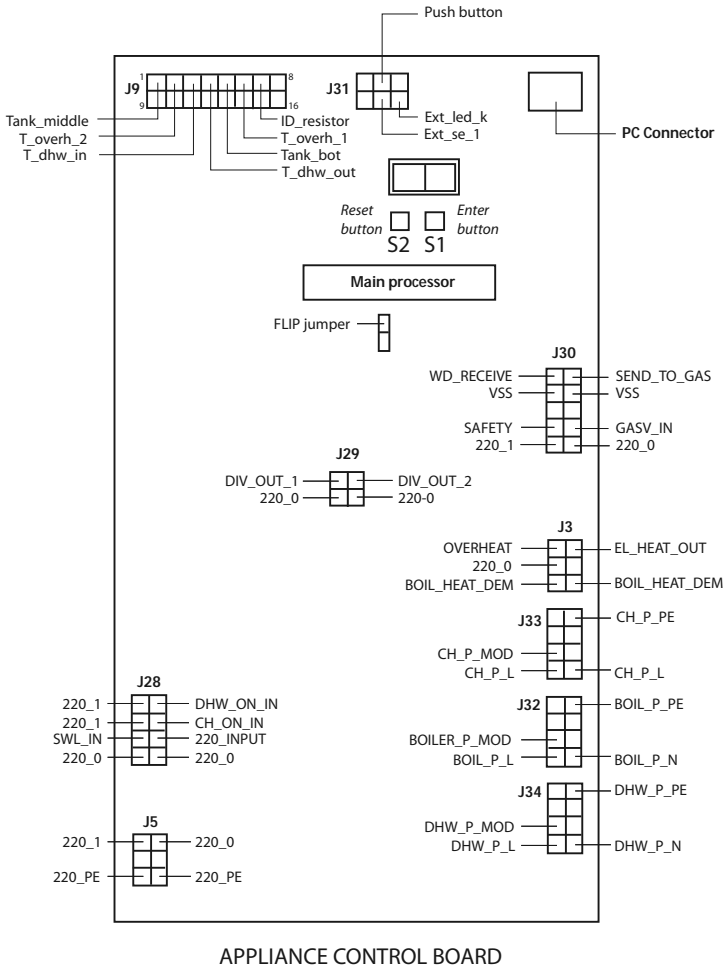

APPLIANCE CONTROL BOARD

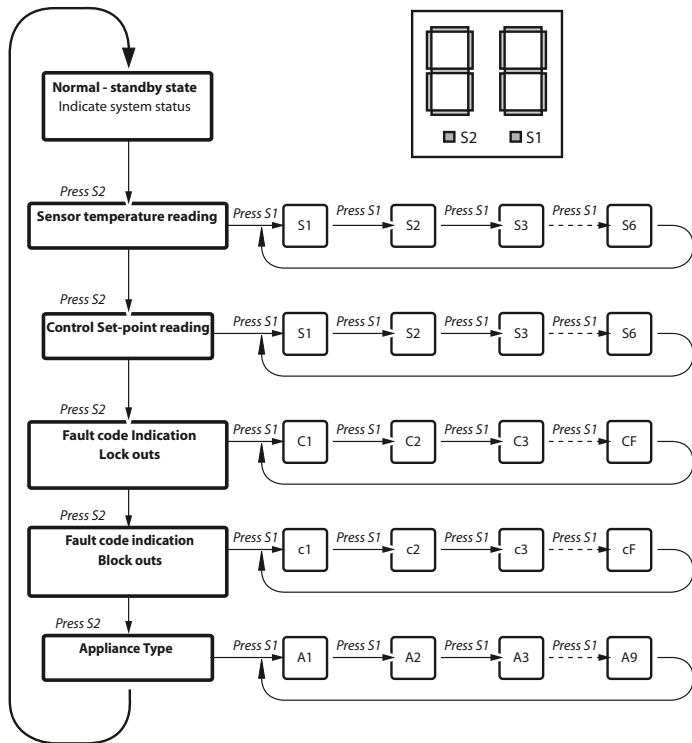

2 Digit ACB Board Display Flow Chart

Appliance Control Board

The appliance control board (shown opposite) has a 2 digit display and 2 push buttons which are used to check the status of the appliance, check and set its identity and interrogate it for the current faults and the fault history.

The 2 digit display is controlled by 2 buttons S1 and S2. The flow chart of display modes is shown below. Generally, each press of button S2 cycles the display from top to bottom and each press of button S1 cycles the display functions from left to right.

The button S2 is also used to reset the appliance i.e. clear the lockout errors and reset the appliance. (Note: Appliance resetting can also be carried out using the push button on the front panel)

Display in Normal (Standby) Mode

In the standard/normal mode the 2 digit display indicates the status of the appliance inputs and outputs by switching on the appropriate segments of the display - see page 29 for details.

Appliance Type Selection

The BoilerMate SP is fitted with an identity (ID) resistor which is read by the controller for comparison with the appliance type (code) set on the controller. The two must match for the controller/appliance to function. Therefore if either the appliance code setting or the ID resistor is wrong, the appliance will shut down safely and flag the error code until the fault is rectified. The controller codes and the ID resistor values for the **BoilerMate SP** are **02** and **2K2** respectively. The procedure for checking and setting the appliance code on the controller is described below.

- The appliance selection menu (A0...A9) on the controller is hidden. It is only possible to get to the appliance selection using the reset button (Left hand, S2) on the main board.

- When going from the show 'locking error' to show 'blocking error' menu (see opposite), do not release the button but hold it for 10 seconds. The display will change from 'c' to 'A'. At this stage the push button (S2) can be released.

- The appliance type can now be selected by using right hand push button, S1, e.g. for this appliance A02.

Press the reset button, S2, to accept the setting.

If the selected appliance code does not match with the ID resistor fitted to the appliance, then, an error '33' will be displayed.

1.0 DESIGN

1.2 TECHNICAL DATA

Sensor Temperature Readings

Details of the various sensors S1-S6 used in the BoilerMate A-Class are shown opposite. The sensor reference i.e. S1 and the actual temperature at that sensor flash alternately on the display when selected.

Sensors used in BoilerMate A-Class			
Sensor	Sensor	Connector J9 pins	Location
S1	T Overheat 1	6 & 14	Top of store in dry pocket (S1 & S2 are in single housing)
S2	T Overheat 2	2 & 10	
S3	T DHW in	3 & 11	In cold water inlet pipe (Wet i.e. direct)
S4	T DHW out	4 & 12	In hot water outlet pipe (Wet i.e. direct)
S5	T Tank bottom	5 & 13	Bottom of store in dry pocket for store charging
S6	T Tank middle	1 & 9	Middle of store in dry pocket for store charging

Sensor Control Set Points		
Display	Sensor	Temp
S1	Middle store sensor on	68
S2	Middle store sensor off	75 - 77
S3	DHW in	35
S4	DHW out	55
S5	Bottom store sensor on	60
S6	Bottom store sensor off	68

Control Set Points

The sensor control set points are shown opposite. PLEASE NOTE THAT THE DISPLAY S1 - S6 IS NOT THE SAME AS THE SENSOR REFERENCE.

Common Fault Codes			
Code		Code	
10	Overheat error	45	S1 overheat 1 shorted
30	Phase error	48	I.D. resistor shorted
33	Appliance selection	49	S4 sensor shorted
37	S1 overheat 1 open	50	S5 sensor shorted
40	I.D. resistor open	51	S6 sensor shorted
41	S4 sensor open	52	S2 overheat 2 shorted
42	S5 sensor open		
43	S6 sensor open		
44	S2 overheat 2 open		
Any other code displayed should be checked against the full chart			

Fault Codes

Fault code locations are numbered C0 - CF and c0 - cF. CO/cO locations hold the latest fault recorded. A code of FF indicates that the fault location is empty. If a sensor is faulty instead of a temperature it will show E1 if open circuit and E2 if short circuit.

1.3 SYSTEM DETAILS

Hot and Cold Water System

General

A schematic layout of the hot and cold water services in a typical small dwelling is shown below. BoilerMate A-Class will operate at mains pressures as low as 1 bar and as high as 5 bar although the recommended range is 2-3 bar. These pressures are the minimum dynamic pressures at the cold connection to the BoilerMate A-Class at the time of the maximum calculated simultaneous demand. If the manifolds (available as an optional extra) are being used the inlet pressure to the manifold must be a minimum of 2 bar. Particular consideration should also be given to available pressures in the case of 3 storey properties. It is also important to check that all other equipment and components in the hot and cold water system are capable of accepting the mains pressure available to the property. If the mains pressure can rise above 5 bar or the maximum working pressure of any item of equipment or component to be fitted in the system a pressure limiting (reducing) valve set to 3 bar will be required.

If you encounter a situation where the water pressure is adequate but flow rates are poor please contact our technical helpline for details of an effective solution.

Note: Each BoilerMate A-Class is fitted with a strainer and flow regulator on the cold mains supply connection. If the supply pressure is less than 2 bar or if the manifolds (available as an optional extra) are being used or if all taps are provided with flow regulators the flow regulator on the cold inlet should be removed.

No check valve or similar device should be fitted on the cold water supply branch to the BoilerMate A-Class.

The Building Regulations L1A: New dwellings/L1B: Existing dwellings and the requirements set out in the Domestic Heating Compliance Guide specify that “where the mains water hardness exceeds 200ppm provision should be made to treat the feed water to water heaters and the hot water circuit of combination boilers to reduce the rate of accumulation of lime scale”

To comply with this requirement the hardness of the mains water should be checked by the installer and if necessary the optional factory fitted in-line scale inhibitor should be specified at the time of order for hardness levels between 200 and 300 ppm (mg/l).

Where the water is very hard ie 300ppm (mg/l) and above the optional polyphosphate type, inhibitor should be specified at the time of order. However, this will need to be fitted by the installer at a suitable point in the cold water supply to the appliance.

If scale should ever become a problem the plate heat exchanger is easily isolated and quickly replaced with a service exchange unit which can be obtained at a nominal cost from Gledhill.

The hot water flow rate from the BoilerMate A-Class is directly related to the adequacy of the cold water supply to the dwelling. This must be capable of providing for those services, which could be required to be supplied simultaneously, and this maximum demand should be calculated using procedures defined in BS 6700.

If a water meter is fitted in the service pipe, it should have a nominal rating to match the maximum hot and cold water peak demands calculated in accordance with BS 6700. This could be up to 80ltr/min in some properties.

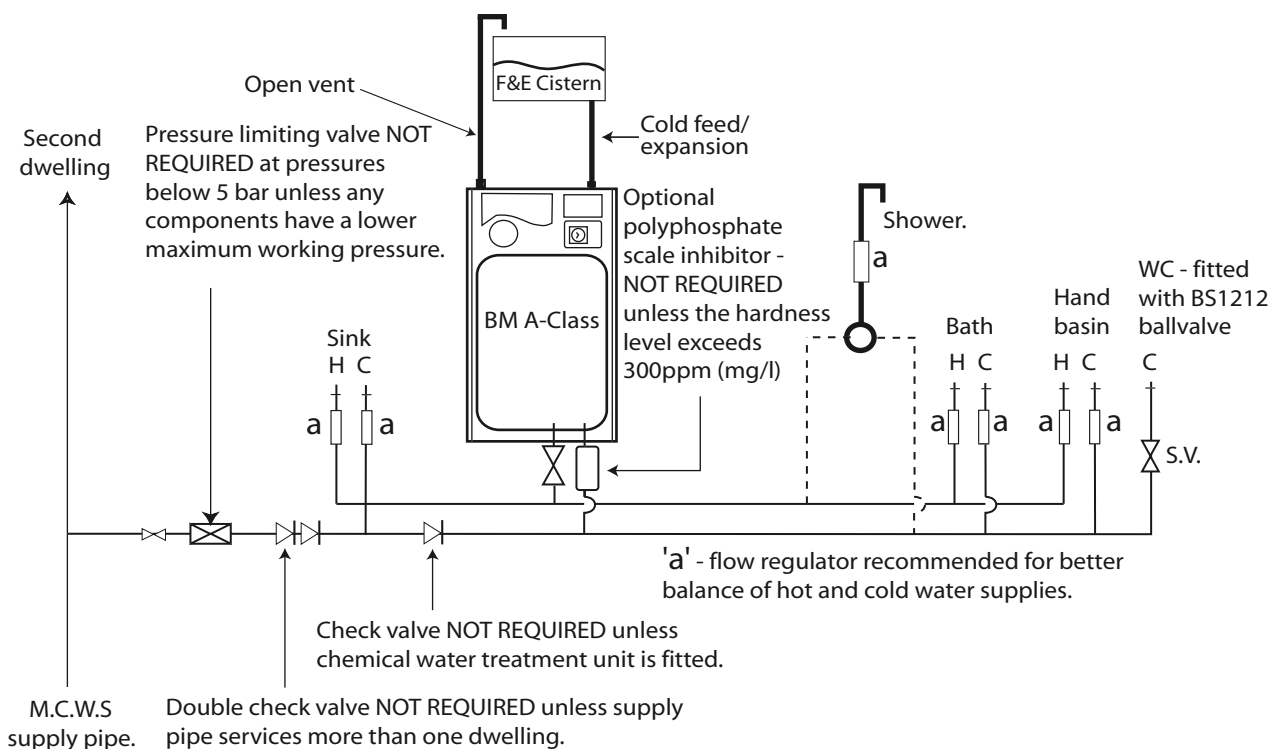

Typical hot and cold water distribution

1.3 SYSTEM DETAILS

Hot and Cold Water System

Pipe Sizing / Materials

To achieve even distribution of the available supply of hot and cold water, it is important in any mains pressure system, that the piping in a dwelling should be sized in accordance with BS 6700. This is particularly important in a large property with more than one bathroom.

However, the following rule of thumb guide lines should be adequate for most smaller property types as long as water pressures are within the recommended range of 2-3 bar.

1. A 15mm copper or equivalent external service may be sufficient for a small 1 bathroom dwelling (depending upon the flow rate available), but the minimum recommended size for new dwellings is 22mm (25mm MDPE). For the BMA 225 model we recommend a 28mm (32mm MDPE) supply pipe.
2. The internal cold feed from the main incoming stop tap to the BoilerMate should be run in 22mm pipe. The cold main and hot draw-off should also be run in 22mm as far as the branch to the bath tap.
3. The final branches to the hand basins and sinks should be in 10mm and to the baths and showers in 15mm. (1 metre minimum)
4. If an external hose tap is provided this should be branched in 15mm pipework from the cold pipework as near to the incoming mains as possible.
5. **We would recommend that best results for a balanced system are achieved by fitting appropriate flow regulators to each hot and cold outlet. This is particularly relevant where the water pressures are above the recommended water pressure range of 2-3 bar, or the dwelling is 3 storey. Details of suitable flow regulators are provided in Appendix A.**

Note: If manifolds (available as an optional extra) are being used suitable flow regulators are automatically provided in the manifold and do not need to be provided at each outlet - See Appendix B for further details.

All the recommendations with regard to pipework systems in this manual are generally based on the use of BS/EN Standard copper pipework and fittings.

However, we are happy that plastic pipework systems can be used in place of copper internally as long as the chosen system is recommended for use on domestic hot and cold water systems by the manufacturer and is installed fully in accordance with their recommendations.

It is also essential that if an alternative pipework material/system is chosen the manufacturer confirms that the design criteria of the new system is at least equivalent to the use of BS/EN Standard copper pipework and fittings.

Taps/Shower Fittings

Aerated taps are recommended to prevent splashing.

Any type of shower mixing valve can be used as long as both the hot and cold supplies are mains fed. However, all mains pressure systems are subject to dynamic changes particularly when other hot and cold taps/showers are opened and closed, which will cause changes in the water temperature at mixed water outlets such as showers. For this reason and because these are now no more expensive than a manual shower we strongly recommend the use of thermostatic showers with this appliance. These must be used in 3 storey properties where the impact on pressure/temperature of opening another tap in the system is greater than normal.

The shower head provided must also be suitable for mains pressure supplies.

However, if it is proposed to use a 'whole body' or similar shower with a number of high flow/pressure outlets please discuss with the Gledhill technical department.

The hot water supply to a shower-mixing valve should be fed wherever practical directly from the BoilerMate A-Class or be the first draw-off point on the hot circuit. The cold supply to a shower-mixing valve should wherever practical be fed directly from the rising mains via an independent branch. The shower must incorporate or be fitted with the necessary check valves to provide back-syphonage protection in accordance with the Water Regulations.

The supply of hot and cold mains water directly to a bidet is permitted provided that it is of the over-rim flushing type and that a type 'A' air gap is incorporated.

Hot and Cold Water System.

If the length of the hot water draw off pipework is excessive the delivery time may be unacceptable before hot water is available at the tap, you may wish to consider using trace heating to the hot water pipework such as the Raychem HWAT system. Please consult Gledhill Technical Department for further details.

It is important that the cold water pipework is adequately separated/protected from any heating/hot water pipework to ensure that the water remains cold and of drinking water quality.

1.0 DESIGN

1.3 SYSTEM DETAILS

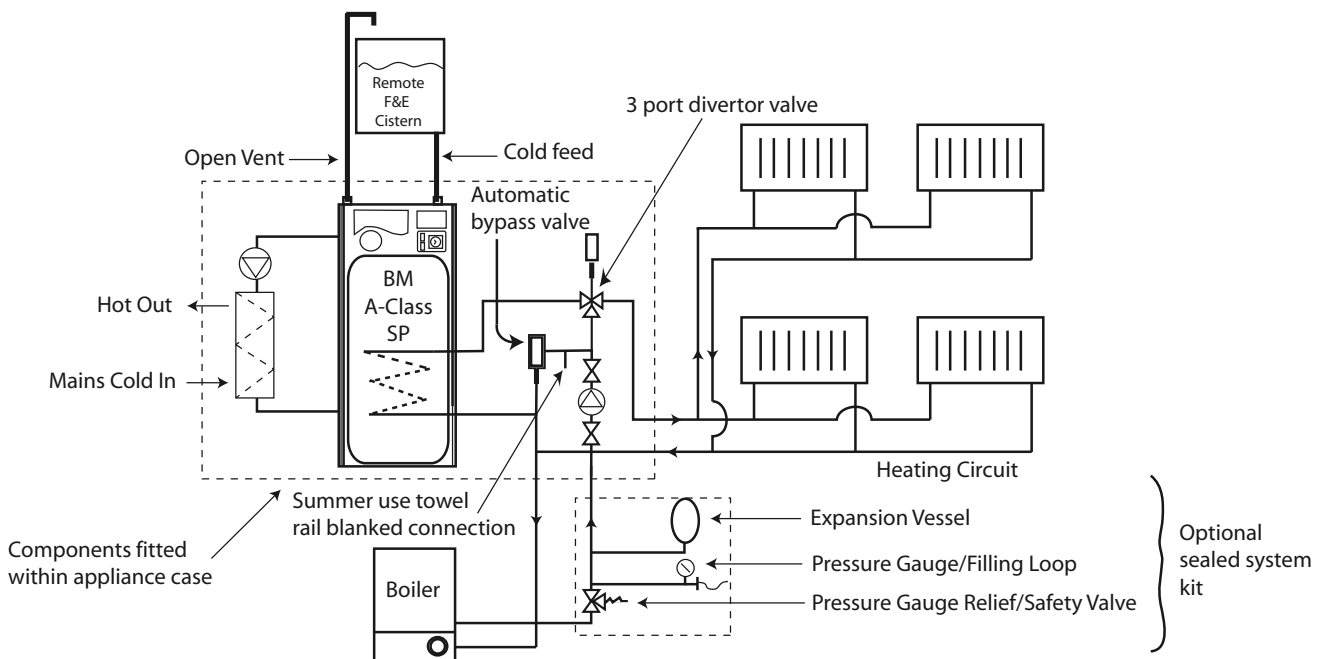

Heating System

General

A schematic layout of the heating system in a typical small dwelling is shown above.

The flow and return from the boiler must always run directly to the BoilerMate A-Class SP and the flow should rise continuously to facilitate venting. The heating circuit is taken from the BoilerMate A-Class and is piped in the conventional manner.

The BoilerMate A-Class SP is only suitable for a sealed heating system and therefore boiler/heating pipework can run at a higher level than the store.

It is recommended that the F & E cistern for the appliance is fitted at high level in the same cupboard as the BoilerMate. However, it can be fitted remotely up to 6m above the base of the BoilerMate A-Class i.e. the maximum static pressure in the store must not exceed 0.6 bar.

The performance of the system pump and the pressure losses through the Systemate 2000 primary coil circuit are shown in 1.2 Technical Data. The nett pump head available for the heating circuit can be determined from these figures and this nett pump head should be used for sizing the heating circuit pipework.

For example: At 24 litres/min primary flow rate, the pressure loss through the Systemate 2000 model SM210 (coil and fittings) is 2.1m W.G. (21kPa). The maximum pump head available at 24 litres/min and setting 3 is 3.2m H₂O (32kPa), therefore 1.1m W.G. (11kPa) is available for the boiler circuit.

With sealed heating systems air is released during the first few weeks of operation. This will need to be vented and the system re-pressurised.

If the automatic model is being used the overflow/warning pipe should be installed in a material suitable for a heating system feed and expansion cistern in accordance with BS 5449.

An automatic bypass is fitted on the BoilerMate A-Class SP to compensate for pressure (i.e. flow) rate changes in the heating circuit e.g. when the thermostatic radiator valves close. The system does not require any other bypass valves but a bypass radiator used in conjunction with a room thermostat can be used if required to provide a boiler interlock. The bypass valve must be set by the installer to suit the system i.e. to provide minimum flow required for the boiler when all TRV's are closed.

There shall be no permanent connection to the mains water supply for filling the system, even through a non-return valve without the approval of the Local Water Authority. An approved filling loop is required with the BoilerMate A-Class (available as part of an optional extra kit) which this should be disconnected after commissioning the system. This should be located adjacent to the boiler along with a suitable expansion vessel gauge and pressure relief valve (also available as part of the optional extra kit) as shown above.

1.0 DESIGN

Heating System

Pipe Sizing/Materials

The BoilerMate A-Class SP is designed to be installed with any condensing or non condensing boiler which is suitable for a sealed heating system (i.e. fitted with an overheat thermostat) and is capable of delivering hot water at a minimum of 80°C.

The primary pipework connecting the boiler and the thermal store should be sized to achieve a maximum of 11°C rise across the boiler or the maximum temperature rise specified by the boiler manufacturer, whichever is smaller, but in any instance it should not be less than 22mm copper tube.

If the boiler is a condensing type the boiler must be set to operate at a normal 82°C flow 71°C return system.

Note: There should be no valves in the pipework connecting the boiler to the BoilerMate A-Class SP and between the boiler and the pressure safety relief valve.

The heating circuit operates on the normal primary boiler temperatures i.e. 82°C flow and 71°C return. Therefore any traditional hot water radiators or convectors can be used with this system and no special over-sizing of the heat emitters is necessary.

1.3 SYSTEM DETAILS

All the recommendations with regard to pipework systems in this manual are generally based on the use of BS/EN Standard copper pipework and fittings.

However, we are happy that plastic pipework systems can be used in place of copper internally as long as the chosen system is recommended for use on domestic heating systems by the manufacturer and is installed fully in accordance with their recommendations. We always recommend the use of barrier pipe for these systems.

It is also essential that if an alternative pipework material/system is chosen the manufacturer confirms that the design criteria of the new system is at least equivalent to the use of BS/EN Standard copper pipework and fittings.

Boiler Size

It is only necessary to calculate the heating requirements in accordance with BS 5449. The allowances shown below should be added for domestic hot water. The control system automatically gives priority to hot water when necessary.

Allowance for Domestic Hot Water	
Model	(kW)
BMA 120 SP	2
BMA 140 SP	3
BMA 180 SP	3
BMA 200 SP	3.5
BMA 220 SP	4

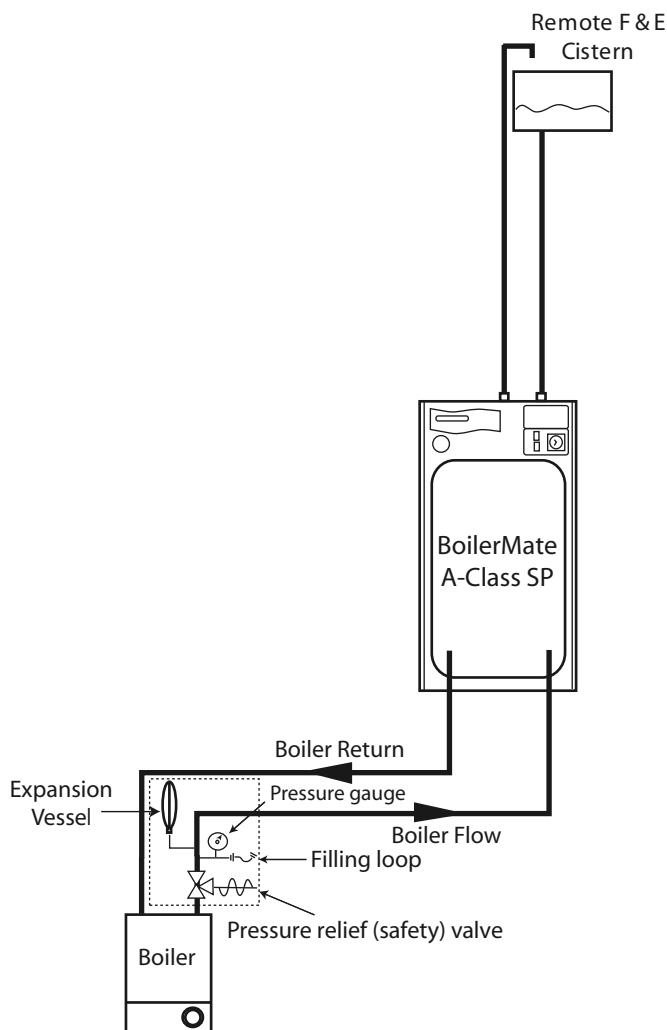

Boiler Sited Below BoilerMate A-Class SP

The size of the primary pipework connecting the boiler to the BoilerMate A-Class must not be less than 22mm (or that specified by the boiler manufacturer).

1.0 DESIGN

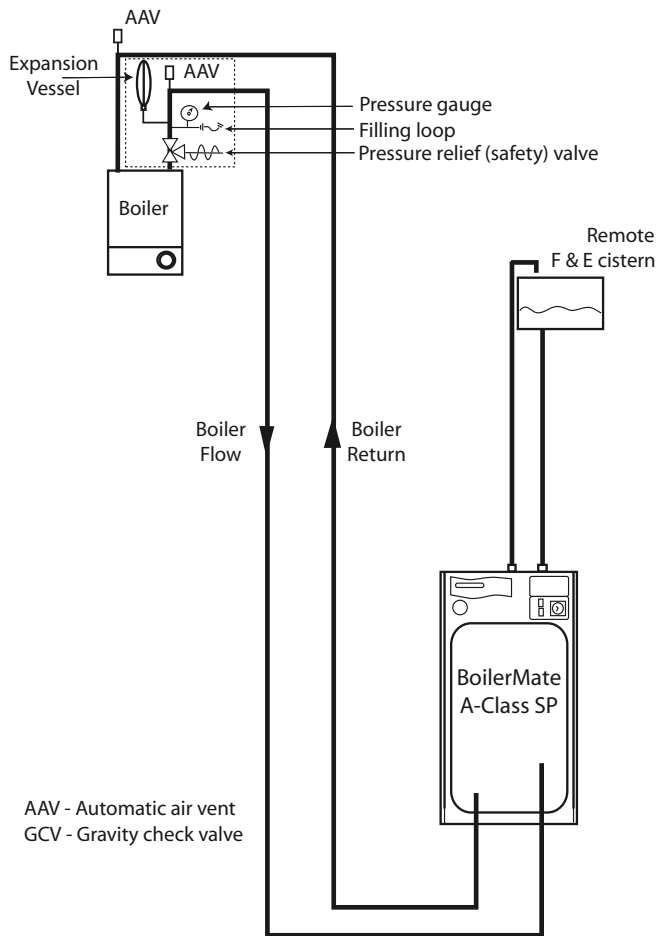

AAV - Automatic air vent
GCV - Gravity check valve

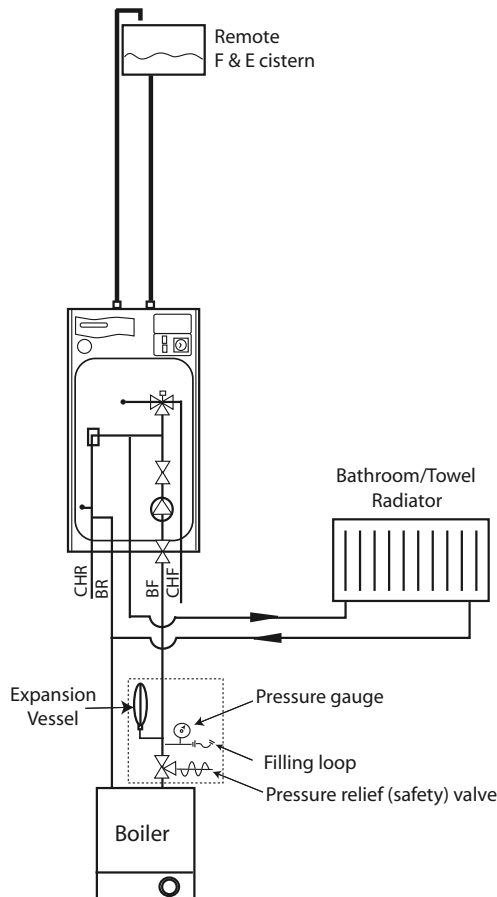

1.3 SYSTEM DETAILS

Heating System

Boiler sited above the BoilerMate or with dipped flow and return pipes

An automatic air vent will be required on the flow adjacent to the boiler and depending upon the pipe layout an automatic or manual air vent will also be required on the return adjacent to the boiler.

The pressure relief (safety valve) must be located on the flow immediately adjacent to the boiler.

Heating System

Connection of Bathroom Radiator/Towel - Rail for Summer use

If a pumped circuit is required for a bathroom radiator/towel rail, the flow pipework can be connected into the 15mm copper blanked connection provided. We recommend any radiators/towel rails on this circuit are provided with T.R.V.'s and that the total heat output of the radiators/towel rails is not more than the figure quoted in the table on page 5.

The radiators will only get hot when the boiler is firing and the store is being heated.

It is important that the flow rates through these radiators is adjusted to the minimum required at the lockshield valves on the radiators. If this is not done the performance of the BoilerMate A-Class SP will be adversely affected.

1.3 SYSTEM DETAILS

Heating System

Method of connecting two BoilerMates to one heat source

If the primary flow and return pipework continuously rises from the boiler to the BoilerMate the recommended method for connecting two BoilerMates to one heat source is to fit the BoilerMates as normal but to provide a single check valve on the common primary return (to boiler) - see diagram below.

The heating and hot water from each appliance must serve separate zones/bathrooms within the property.

The electrical supplies from each appliance to the boiler will need twinning so that the boiler will operate on a call from either/both appliances.

Both primary pumps and the primary pipework sizes should be checked to ensure that they are adequate for the system that has been installed. If necessary an extra pump should be fitted on the common primary return pipework - see diagram below.

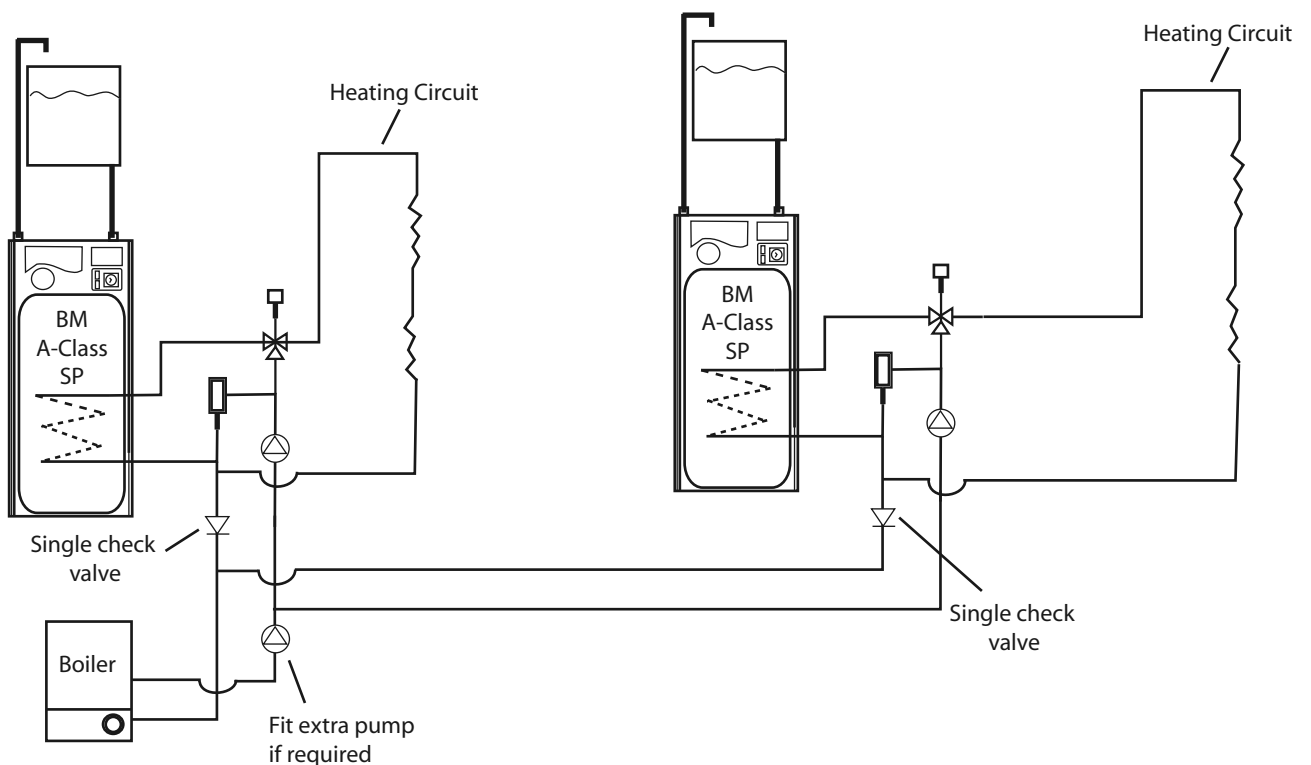

1.3 SYSTEM DETAILS

Heating System

Expansion Vessel Requirements

The BoilerMate expansion vessel is pre-charged to 1.0 bar. The maximum water content of the heating system (boiler + radiators + connecting pipework + primary coil but NOT store volume) must not be greater than those shown in the table below.

A figure of 4.5 litres/kW of installed radiator capacity can be used for a preliminary assessment of the water content of the heating system.

The values presented in the table are based on a maximum boiler flow temperature of 93°C. The expansion vessel must be suitable to accommodate the change in volume of the water in the system when heated from 10°C to 110°C as specified in BS 5449: 1990 clause 16.2.

The primary heating coil and pipework volumes are shown in the table in 1.2 Technical Data.

In normal circumstances an initial vessel and system charge pressure of 1 bar is suitable for most domestic purposes.

The minimum system pressure should not be less than the static head plus 0.5 bar i.e. the height of the highest point in the system above the expansion vessel plus a margin of 0.5 bar.

If the system volume is greater than that shown in the table at the selected operating conditions then an additional expansion vessel must be fitted.

12 Litre Vessel i.e. BMA 120/140/180

Maximum Recommended Heating System Volumes

Safety valve setting (bar)	3.0							
Vessel charge pressure (bar)	0.5			1.0			1.5	
Initial system pressure (bar)	0.5	1.0	1.5	1.0	1.5	2.0	1.5	2.0
Maximum permitted system volume (litres)	140	80	40	110	60	27	70	35

25 Litre Vessel i.e. BMA 200/220

Maximum Recommended Heating System Volumes

Safety valve setting (bar)	3.0							
Vessel charge pressure (bar)	0.5			1.0			1.5	
Initial system pressure (bar)	0.5	1.0	1.5	1.0	1.5	2.0	1.5	2.0
Maximum permitted system volume (litres)	270	160	85	200	115	50	140	65

1.0 DESIGN

1.3 SYSTEM DETAILS

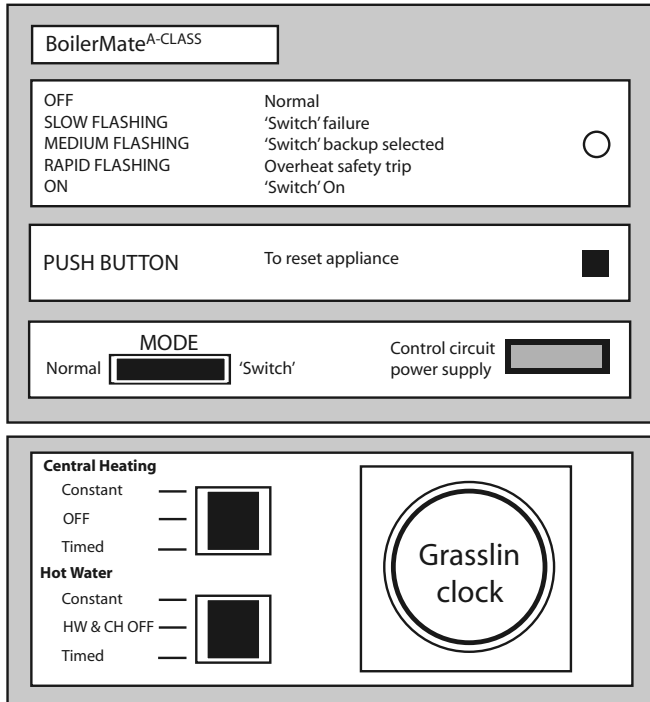

'Switch'

The BoilerMate A-Class SP is supplied with 'Switch' which provides a 6kW electrical emergency back up in the case of failure of the main heat source i.e. gas boiler.

This must NOT be used to provide hot water only in summer if the main system is working correctly.

Full details of the electrical requirements are provided in Section 2.1 Site Requirements and 2.2 Installation.

'Switch' will be activated by moving the mode rocker located on the front control panel into the 'switch' position (see diagram opposite). This replaces the function of the external boiler with the internal electric emergency boiler. The programming of space heating and store charging is still controlled by the clock and the hot water and central heating control rockers.

For emergency hot water only put the mode rocker into 'Switch' position, the hot water control rocker in the constant position and the central heating rocker to off.

For emergency hot water and heating put the mode rocker into 'Switch' position and the hot water and central heating control rockers in the constant position.

In this situation the store will charge and the space heating will be available at all times.

Once the fault has been resolved return to normal boiler operation by moving the mode rocker to the normal position and reset the hot water and central heating control rockers to the required position.

During Switch operation the central heating can be operated in a timed mode if required by setting the central heating control rocker to timed and the clock/programmer to suit the times required.

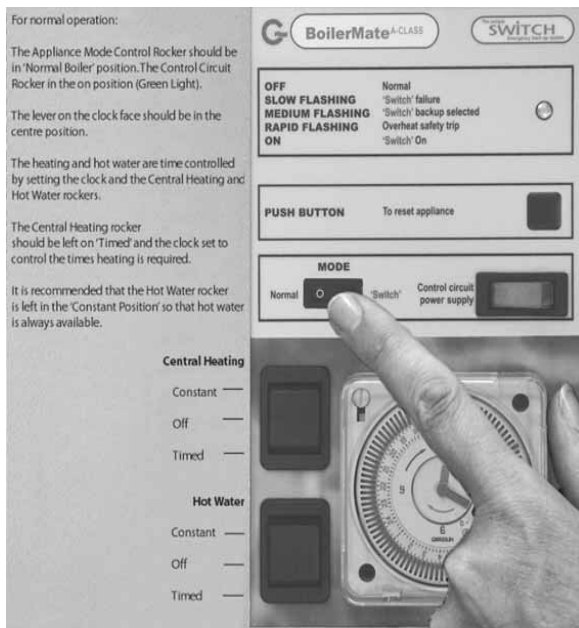

Put Mode Rocker to 'Switch' position

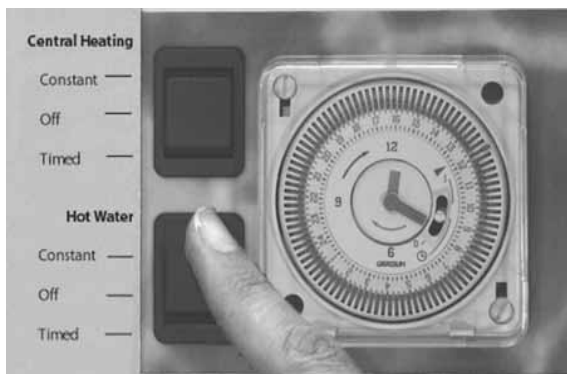

Select HW Only

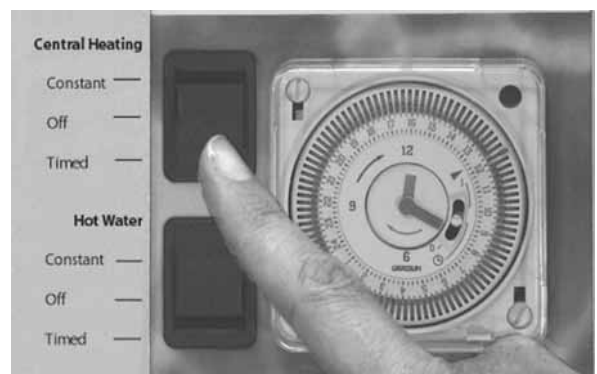

Select HW & CH

2.1 SITE REQUIREMENTS

The appliance is designed to be installed in an airing/cylinder cupboard and the relevant minimum dimensions are provided in section 1.2 Technical Data.

Because of the ease of installation we recommend that the cupboard construction is completed and painted before installation of the appliance. The cupboard door can be fitted after installation.

If the unit needs to be stored prior to installation it should be stored upright in a dry environment and on a level base/floor.

Installation and maintenance access is needed to the front of the appliance and above the F & E cistern. See Technical Data section for further details.

The minimum dimensions contained in section 1.2 Technical Data allow for the passage/connection of pipes under the appliance from any direction as long as the appliance is installed on the installation base provided. If the installation base is not used extra space may be needed to allow connection to the pipework and the whole of the base area should be continuously supported on a material which will not easily deteriorate if exposed to moisture.

The floor of the cupboard needs to be level and even and capable of supporting the weight of the appliance when full. Details of the weight when full is provided in section 1.2 Technical Data.

The appliance is designed to operate as quietly as practicable. However, some noise (from pumps etc) is inevitable in any heating system. This will be most noticeable in cupboards formed on bulkheads, or at the mid span of a suspended floor. In these cases the situation can be improved by placing the appliance on a suitable sound deadening material (i.e. carpet underlay or similar).

Cupboard temperatures will normally be higher than in a conventional system and the design of the cupboard and door will need to take this into account. No ventilation is normally required to the cupboard.

A suitable location will be needed for the separate feed and expansion cistern. This will often be at high level in the cupboard housing the BoilerMate A-Class. The dimensions and clearances are provided in section 1.2 Technical Data. The location will need to provide a suitable route for the cold feed and expansion pipe as well as the open safety vent pipe. The location will also need to provide a suitable route and discharge position for the warning/overflow pipe and the ball valve supply from the mains cold water system if the automatic fill version appliance is being fitted.

Note: The standard appliance is supplied with a cistern but without a ball valve and overflow connector.

Nominal full load current	Min rating of the isolator	Cable size	Max. recommended cable run-based on not exceeding 4% of the nominal voltage supply of 230 VAC using a type B breaker
28.5 Amps	32 Amps	6 mm ²	44 metres
Recommended circuit protection device - based on 0.4 second disconnection time		32 A type B circuit breaker to BS EN 60898 or 32A type B RCBO to BSEN 61009	

Electrical Supply requirements for BoilerMate A-Class

An electrical supply must be available which is correctly earthed, polarized and in accordance with the latest edition of the IEE requirements for electrical Installations BS 7671.

The electrical mains supply needs to be 230V/50Hz.

A means for disconnection from the supply mains having a contact separation in all poles that provides full disconnection under over voltage category III conditions must be incorporated in the fixed wiring in accordance with the wiring rules. This shall be located within 1m of the appliance and only serve the appliance.

The minimum breaking capacity of the main isolator and cable sizes/lengths at 230V shall follow the recommendations in the table shown opposite.

If the boiler incorporates a frost thermostat an extra 3 core 3 amp supply cable will be required between the boiler and the BoilerMate to provide a supply to the boiler pump - see 2.2 Electrical Connection for further details.

2.2 INSTALLATION

Preparation/placing the appliance in position.

Details of the recommended positions for termination of the first fix pipework are provided in section 1.2 Technical Data. The pipework can be located or its position checked using the template provided with each appliance. If these have been followed installation is very simple and much quicker than any other system.

The appliance is supplied shrink wrapped on a timber installation base. Carrying handles are also provided in the back of the casing.

The feed and expansion cistern complete with cold feed/expansion pipework and if ordered a ballvalve and overflow/warning fittings are provided in a separate box. If flexible connections have been ordered these will also be inside the feed and expansion cistern.

The appliance should be handled carefully to avoid damage and the recommended method is shown opposite. Before installation the site requirements should be checked and confirmed as acceptable. The plastic cover and protective wrapping should be removed from the appliance and the installation base (provided) and placed in position.

The appliance can then be lifted into position in the cupboard on top of the base and the front panel removed by unscrewing the 2 screws and lifting the door up and out, ready for connection of the pipework and electrical supplies. The feed and expansion cistern support shall be installed ensuring that the base is fully supported and the working head of the appliance is not exceeded and the recommended access is provided for maintenance - see section 1.2 Technical Data. For further information on manual handling See Appendix D.

Note: Although the above guidance is provided any manual handling/lifting operations will need to comply with the requirements of the Manual Handling Operations Regulations issued by the H.S.E.

The appliance can be moved using a sack truck on the rear face although care should be taken and the route should be even.

In apartment buildings containing a number of storeys we would recommend that the appliances are moved vertically in a mechanical lift.

If it is proposed to use a crane expert advice should be obtained regarding the need for slings, lifting beams etc.

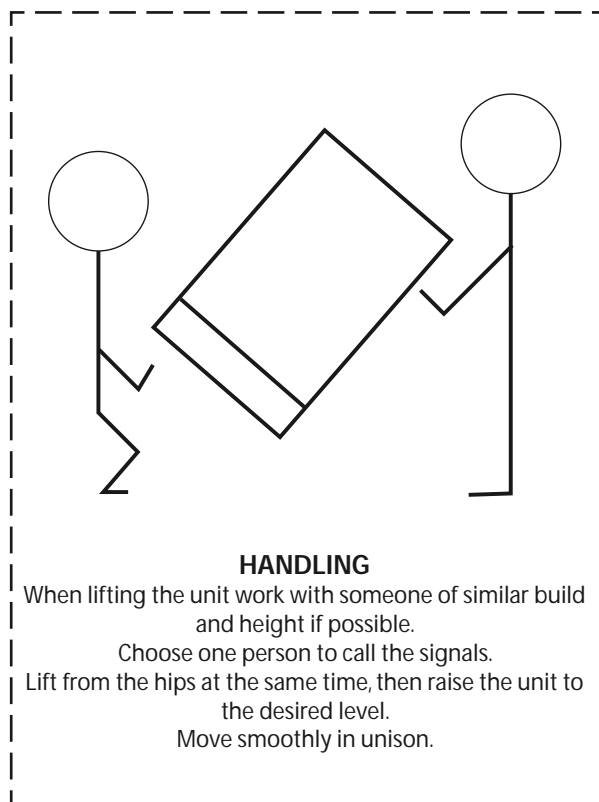

A specific manual handling assessment is shown in Appendix D at the rear of this manual.

2.0 INSTALLATION

2.2 INSTALLATION

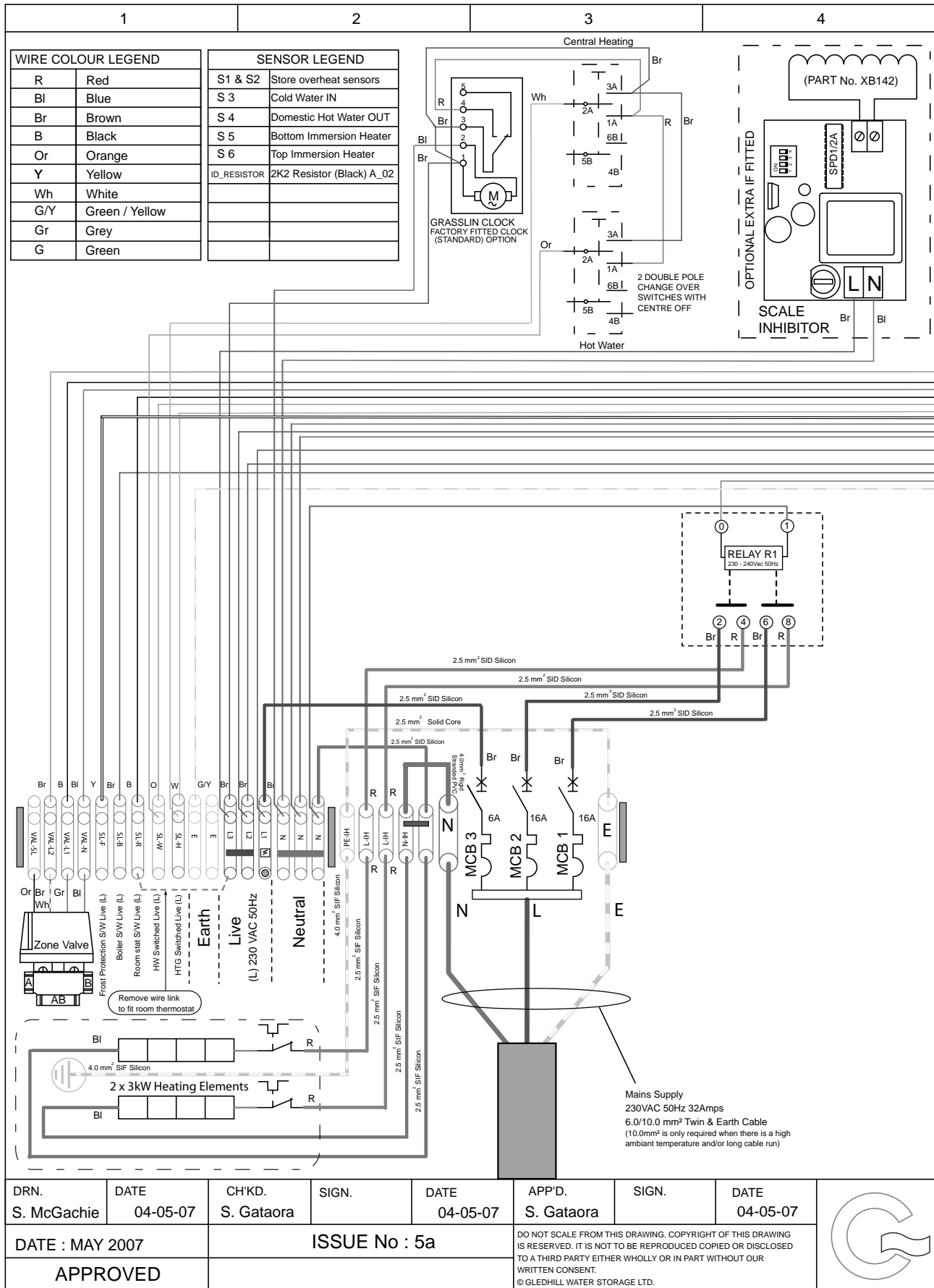

2.0 INSTALLATION

2.2 INSTALLATION

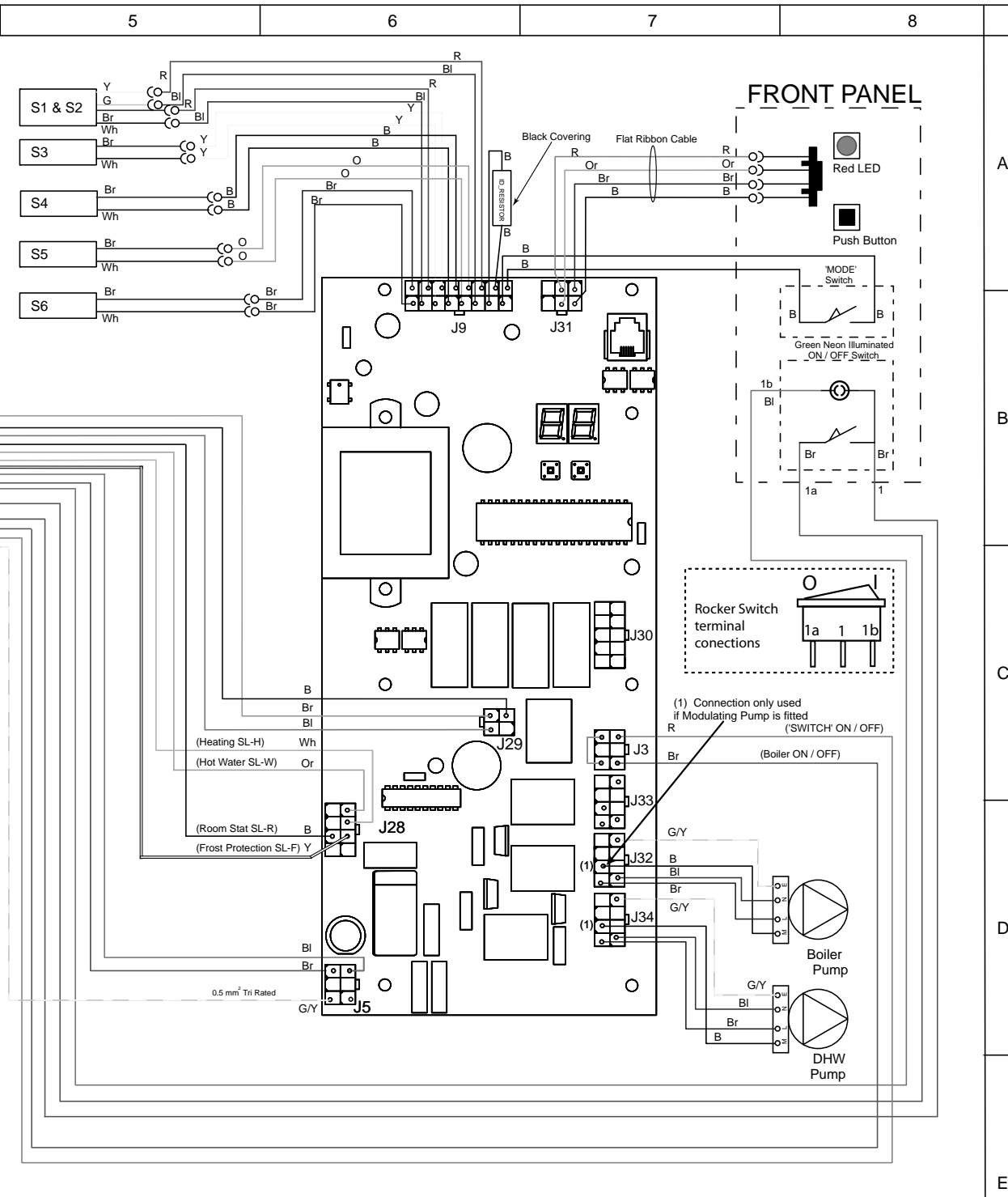

* All wire sizes 0.5mm² Tri-Rated cable unless otherwise stated

GLEDHILL WATER STORAGE LTD.
 SYCAMORE TRADING ESTATE
 SQUIRES GATE LANE
 BLACKPOOL
 LANCASHIRE
 FY4 3RL

TITLE
 BOILERMATE 'A' Class SP
 with Clock (Factory Standard)
 New Rail Layout

JOB NAME
 Electrical Schematic for BOILERMATE 'A' class SP
 appliance with factory fitted clock

DRG. SIZE DRG. NAME
 A3 'A' Class BoilerMate SP ver 5a.ai

BOILERMATE A-CLASS SP

2.0 INSTALLATION

2.2 INSTALLATION

Pipework connections

The position of the pipework connections is shown opposite. The connection sizes and dimensions are listed in Section 1.2 Technical Data.

All the connections are also labelled on the appliance. It is essential that the pipework is connected to the correct connection.

Connections A, B, D, E and F are plain ended copper pipe.

Connections C, G and H are compression fittings.

Connection I is RC $\frac{1}{2}$ ($\frac{1}{2}$ in BSPT internal).

Connection J is a blanked copper pipe.

- A - Safety open vent
- B - Cold feed/expansion
- C - Primary flow (from boiler)
- D - Primary return (to boiler)
- E - Central heating return
- F - Central heating flow
- G - Domestic hot water
- H - Incoming mains cold water
- I - Drain (valve is not provided with the appliance)
- J - Primary flow for pumped summer towel rail circuit (see page 16)

Note: The safety open vent and cold feed/expansion must be connected to the F & E cistern using the pipework assembly provided. Do not alter or connect any pressure-relief device to the vent pipe of this water heater.

All factory made joints should be checked after installation in case they have been loosened during transit.

The fittings for the feed and expansion cistern should be installed following the instructions provided in a position to suit the particular location and the cistern fitted on its supports/base.

The cold feed/expansion and safety open vent should be installed between the appliance and the feed and expansion cistern.



2.2 INSTALLATION

It is normally envisaged that the feed and expansion cistern will be located in the same cupboard as the BoilerMate appliance itself to maintain a dry roof space.

The cold feed/open vent pipework assembly (as supplied) is all that is required if it is intended to install the F & E cistern directly on top of the appliance

However, if it is necessary to locate the cistern in the roof space (or on a higher floor) the cold feed/open vent pipework assembly (as supplied) should be used to connect to the F & E cistern and pipework site run by the installer to connect this to the appliance.

Note: When fitting the cistern at a higher level this must not be fitted more than 6 metres above the base of the BoilerMate A Class appliance.

Obviously, if installed in the roof space the feed and expansion cistern and any pipework will need to be adequately insulated to protect against frost damage.

Combined feed and open vent pipe arrangements must not be used.

No valves should be fitted in the safety open vent which must be a minimum of 22mm copper pipe or equivalent.

If the automatic fill version appliance is used the overflow/warning pipe shall have a continuous fall, be fitted to discharge clear of the building and be sited so that any Overflow can be easily observed. It shall also be installed in a size and material suitable for use with heating feed and expansion cisterns in accordance with BS 5449 and should not have any other connections to it.

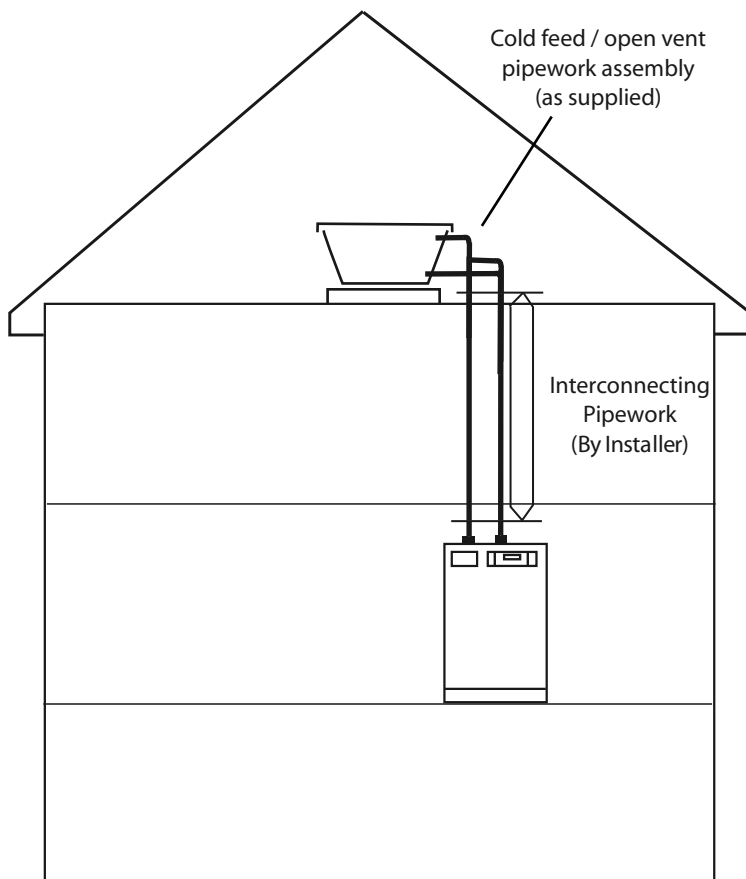

2.2 INSTALLATION

Electrical Connection - Standard Appliance

The BoilerMate A-Class SP is pre-wired to DIN rail terminals from the A.C.B. and plumbers are well able to complete the electrical installation provided they adhere strictly to the IEE Requirements for Electrical Installations BS 7671.

All the terminals are suitably labelled.

Note: Do not attempt the electrical work unless you are competent to carry it out to the above standards.

Before commencing check that the power source is in accordance with section 1.2 Site Requirements and ensure that it is isolated.

Run the external wiring through the service slot provided in the base of the appliance.

The 2 & E core input cable from the isolator to the appliance must not be less than 6mm² PVC grade to BS 6500.

This supply cable must be fed via a 32 amp double pole isolator no more than 2 metres from the appliance.

Make the connections as shown opposite.

The appliance is provided with a link between terminals SL_R and L2 on the terminal connections. This must be removed if a room thermostat is fitted see opposite.

Clamp the cables in the grips provided below the terminal connections and ensure all cables are routed to avoid hot surfaces.

The supply to the BoilerMate A-Class must be protected by a type B MCB to BS EN 60898 of at least 32 amps rating.

Two installer supplied flex cables are required to connect external room thermostat and boiler. These cables must each be 4 core and at least 1mm² or above in size.

For maintenance purposes it is essential that an all pole isolator is positioned within 2 metres of the remote boiler installation, this helps in future maintenance to current Corgi requirements.

NOTE: The appliance controller is polarity sensitive therefore if the live and neutral cables are connected incorrectly the red light on the front panel will flash rapidly and can not be reset by operating the push button.

BOILERMATE 'A' CLASS EXTERNAL CABLE CONNECTION DIAGRAM

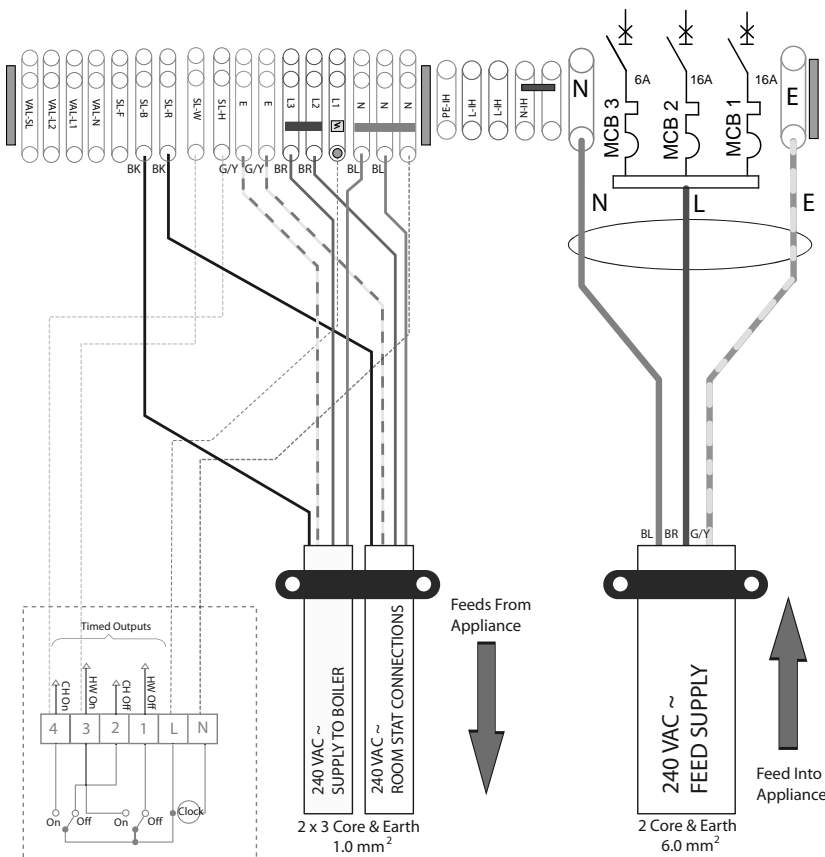

On a 'No Clock Option' an external 2 channel controller must be supplied separately and connected as above.
(Factory Fitted Links between L1-SL_H - SL_W will need to be removed)

INSTALLER ELECTRICAL CONNECTIONS

2.0 INSTALLATION

2.2 INSTALLATION

The BoilerMate A-Class incorporates a pump overrun for the boiler pump and terminal L1 on the terminal strip (as shown on page 23) should only be used if the boiler requires a permanent live for another purpose.

The boiler manufacturers wiring instructions should be read in conjunction with this manual.

Before switching on the electrical supply check all the factory made terminal connections to ensure they have not become loose during transit.

Frost Protection

When frost protection is required for the whole house or where a base temperature is required during cold weather the central heating and hot water control rocker switches should be put in the constant position and the room thermostat adjusted to a suitable setting.

When the location of the boiler means that frost protection is required for the boiler circuit only a frost thermostat and pipe mounted thermostat should be fitted in the normal way and wired back to the special terminal provided in the appliance as shown below.

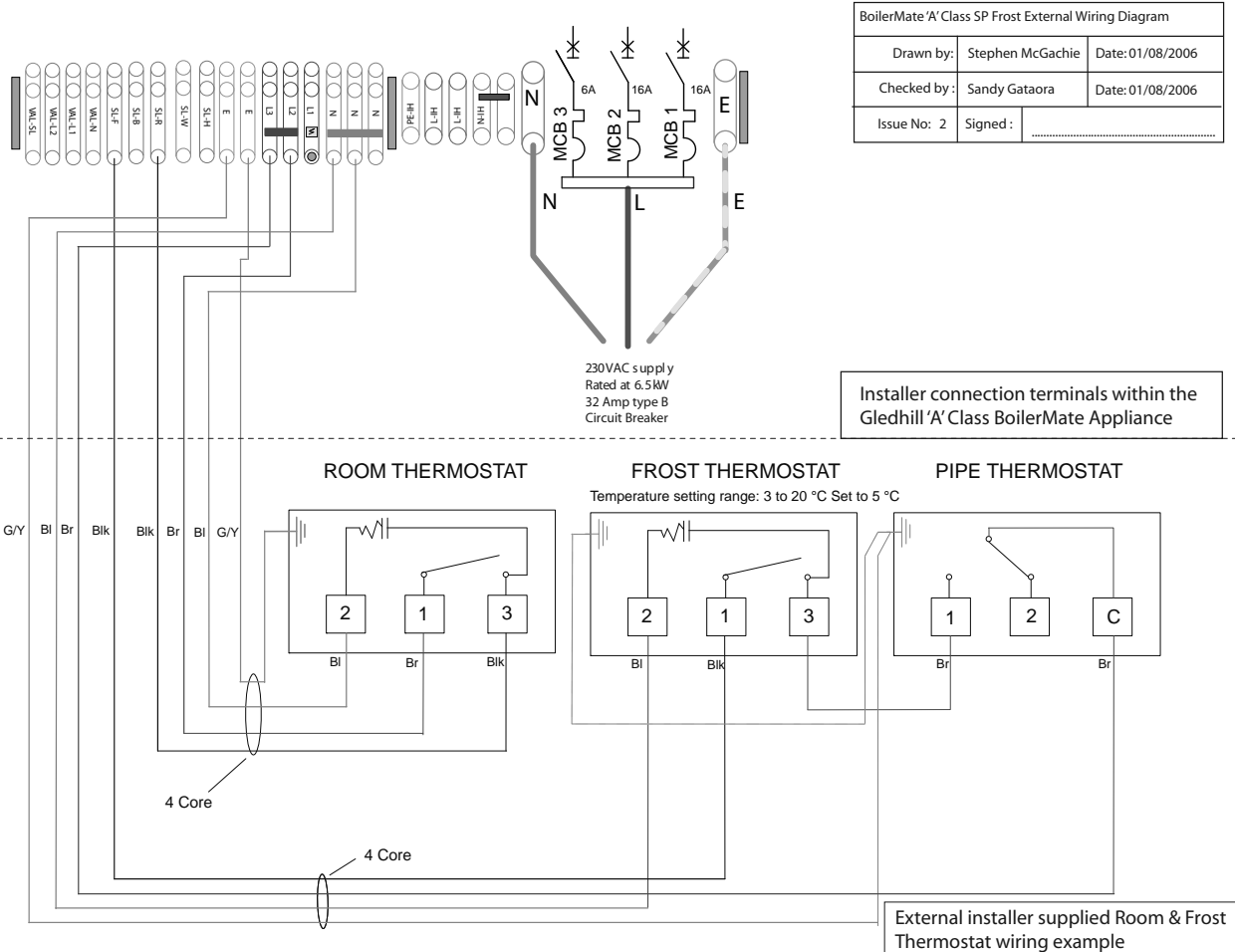

2.0 INSTALLATION

2.2 INSTALLATION

Electrical Power Supplies - BoilerMate A-Class with Switch.

WARNING: THE BOILERMATE A-CLASS IS FITTED WITH AN ELECTRIC BACKUP SYSTEM 'SWITCH':

IMPORTANT: ELECTRICIAN/INSTALLER PLEASE NOTE.

THE 2 x 16A MCB's (MCB1 and MCB2) FOR THE 'SWITCH' ELECTRIC BACKUP SYSTEM ARE SUPPLIED SET IN THE 'OFF' POSITION BY AN ADHESIVE WARNING LABEL. MCB3 IS SUPPLIED SET IN THE 'ON' POSITION. THE GAS BOILER CAN BE COMMISSIONED WITH THE SWITCHES IN THESE POSITIONS AND MCB1 AND 2 MUST NOT BE SWITCHED ON BEFORE THE GAS BOILER HAS BEEN FULLY TESTED/COMMISSIONED.

AFTER THE GAS BOILER HAS BEEN COMMISSIONED MOVE MCB'S 1 AND 2 TO THE 'ON' POSITION WHICH WILL BREAK THE WARNING LABEL AND THEN COMMISSION THE SWITCH FACILITY.

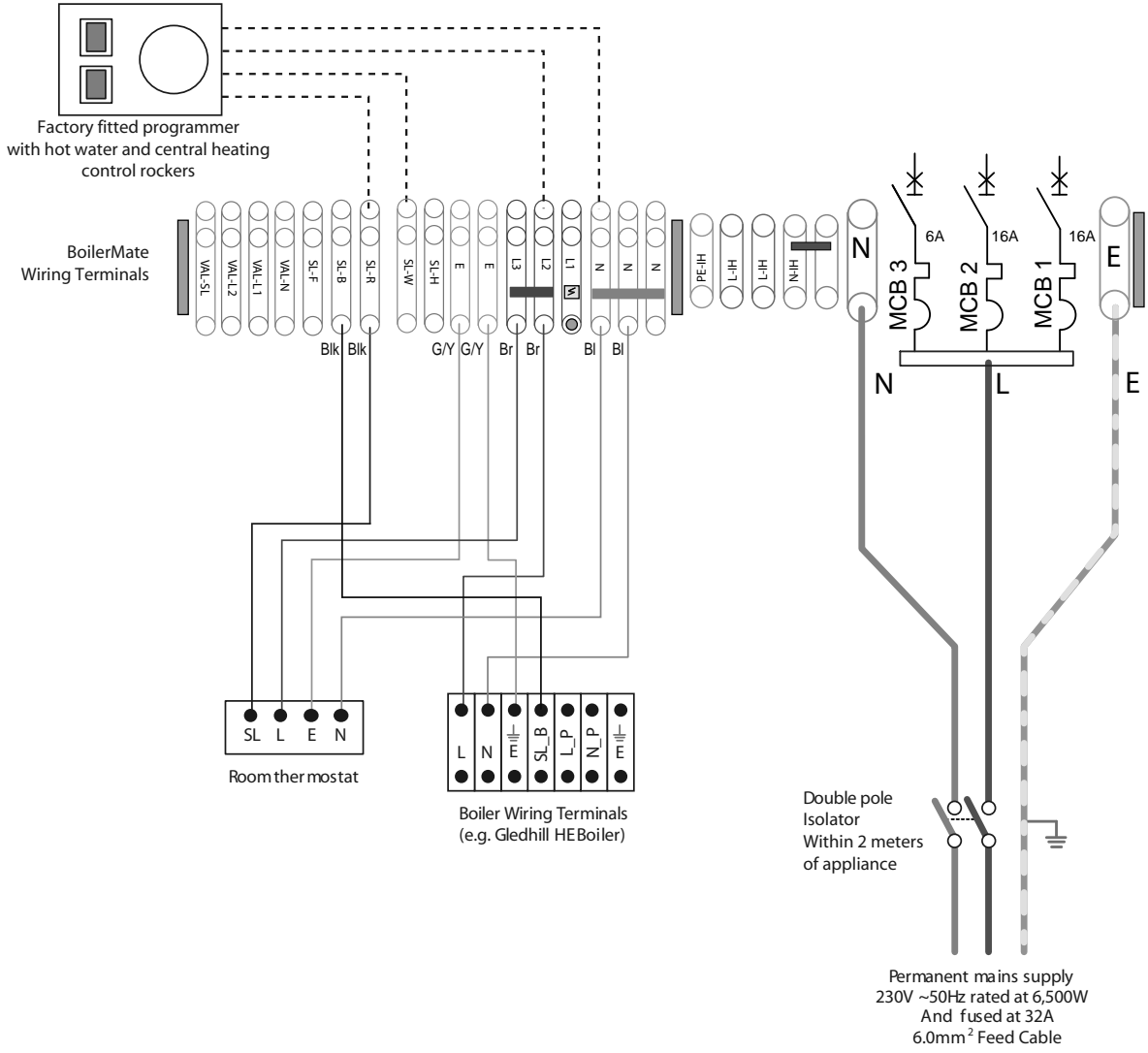

Typical external wiring of a standard BoilerMate with 'Switch'

2.2 INSTALLATION

Zoned heating systems

BoilerMate is available in a no clock/multi-zone version for use where a property has to have its space heating zoned. Where this appliance version is to be used it is recommended that the BoilerMate is located on a raised platform in the cupboard creating a space below the appliance to locate the zoning equipment. The recommended height of the platform from the floor is 250mm. The platform must be constructed in a material that will not easily deteriorate if exposed to moisture. It must also be capable of supporting the weight of the appliance when full. Details of the weight when full is provided in section 1.2 Technical Data.

Connecting the zones to the BoilerMate.

The space heating flow should be taken from the BoilerMate connection into the space below the platform. The flow can now be split into the appropriate amount of zones and a controlling zone valve fitted to each branch. Each flow can then be piped to its radiator zone and the heating return brought back to the space below the platform. The heating returns can now be connected together before a single connection is made to the heating return on the BoilerMate.

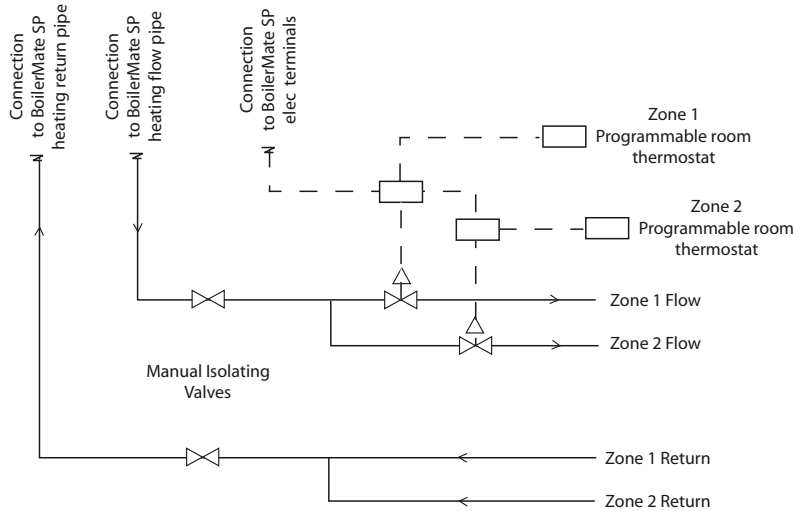

TYPICAL SCHEMATIC ARRANGEMENT OF MULTIZONE HEATING

NOTE: ONLY 2 ZONES ARE SHOWN FOR CLARITY BUT FURTHER ZONES CAN BE ADDED IN THE SAME WAY IF REQUIRED

Note: Remove link from L1 to SLR when fitting time controls for heating. Remove link from L2 to SLW when fitting time control for hot water.

A typical way of providing heating and hot water time control is shown below. However, other methods can be used such as using a 3 channel programmer if required.

BOILERMATE MULTI-ZONE EXTERNAL WIRING DIAGRAM

Note: Terminals L3 AND SL-H must be linked in a no clock/multi-zone option.

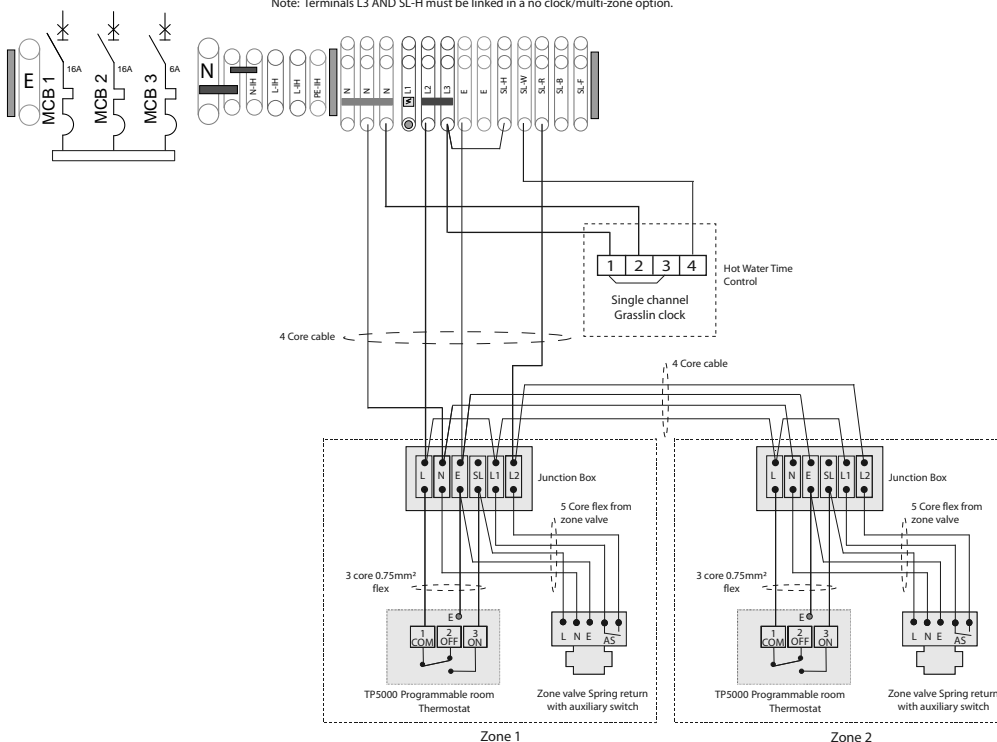

2.0 INSTALLATION

2.2 INSTALLATION

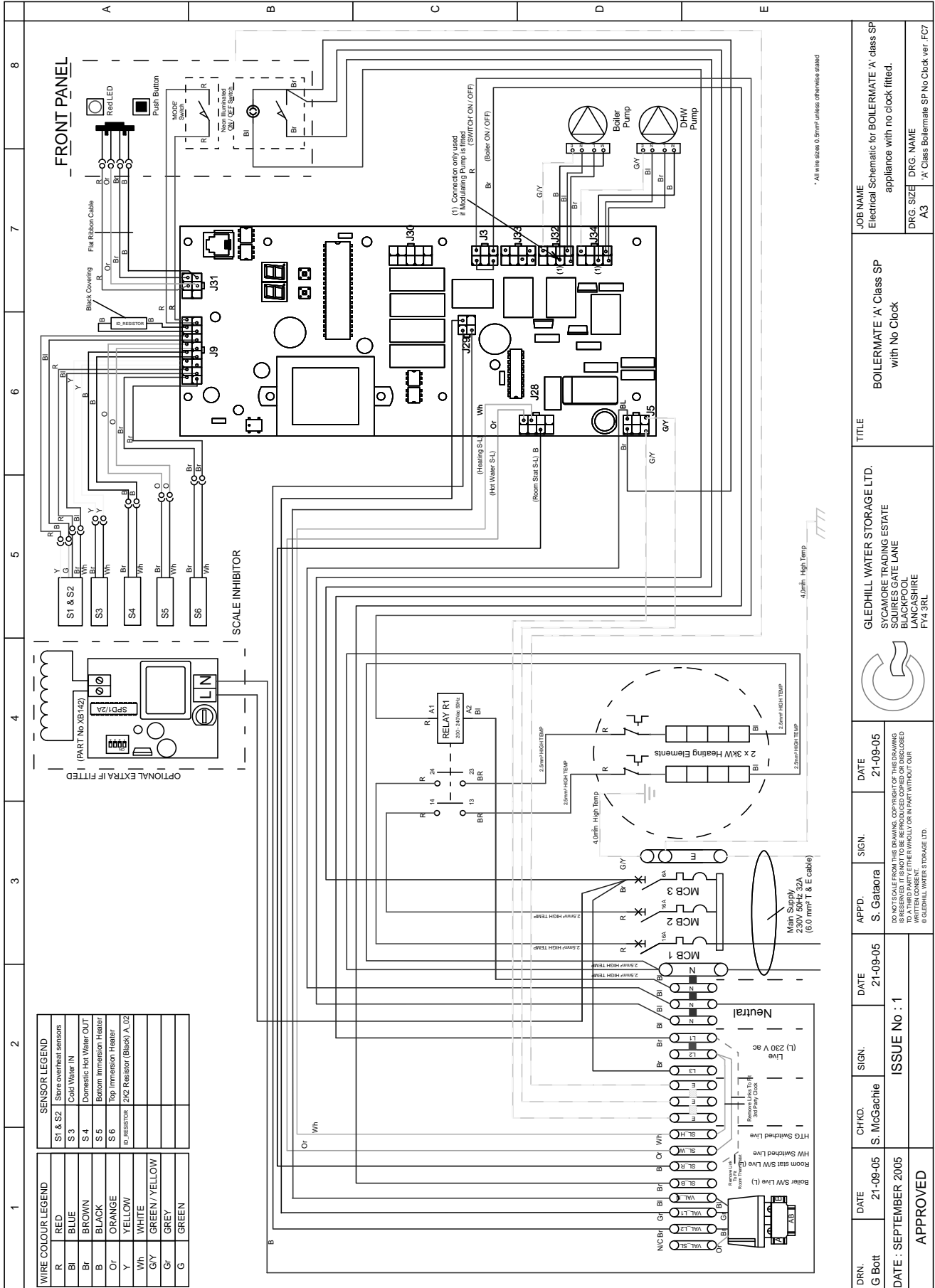

JOB NAME	Electrical Schematic for BOILERMATE 'A' class SP appliance with no clock fitted.
DRG. SIZE	DRG. NAME
A3	'A' Class Boilermate SP No Clock ver. FC7

TITLE	BOILERMATE 'A' Class SP with No Clock
-------	---------------------------------------

GLEDHILL WATER STORAGE LTD.
SYCAMORE TRADING ESTATE
BLACKPOOL
LANCASHIRE
FY4 3RL



DATE	21-09-05
SIGN.	S. Gataora
APPD.	S. Gataora

DATE	21-09-05
SIGN.	S. McGachie
CHKO.	S. McGachie

DATE	21-09-05
DRN.	G Bott
DATE	SEPTEMBER 2005
ISSUE No :	1
APPROVED	

2.3 COMMISSIONING

Open the incoming stop valve and fill the domestic mains cold and hot water systems.

Check and adjust as necessary the expansion vessel air pressure to the figure specified (normally 1.0 bar).

Fill the whole of the primary heating system with potable water through the filling loop provided adjacent to the boiler to the pressure required (normally 1.0 bar).

During filling vent air as necessary from the high points of the system including the manual air vents provided on the appliance and the feed to the expansion vessel.

Fill the appliance i.e. BoilerMate A-Class through the feed and expansion cistern flush and refill.

Check the water level in the feed and expansion cistern and adjust the ballvalve if fitted.

Check the warning pipe (if fitted) is installed correctly, has a continuous fall and is not blocked i.e. discharges water freely.

Check the whole of the primary heating and domestic hot and cold distribution system, including the boiler and BoilerMate SP, for leaks.

It is essential that all systems function properly for optimum performance.

To achieve this, the primary system should be commissioned in accordance with good practice and generally in accordance with the requirements of BS 6798, BS 5449 and BS 7593.

Full details of the requirements are given in PAS 33:1999 under Section 10 Commissioning.

When using either cleansing or corrosion inhibitor chemical, the manufacturers instructions must be followed.

Cleansing the Primary System

It is very important to ensure that the Primary system is cleaned using a suitable cleansing agent such as Sentinel X300 or Fernox Superfloc to ensure that any flux residues/installation debris are removed.

The volumes/concentration should be calculated in accordance with the manufacturers instructions allowing the volume for the primary coil shown in the Table in 1.2 Technical Data.

Primary Water System Treatment

Although the BoilerMate A-Class SP has no special water treatment requirements, the radiators and other parts of the circuit will benefit from the application of a scale and corrosion inhibitor such as Sentinel X100 or a Protector such as Fernox MB1.

The volumes/concentration should be calculated in accordance with the manufacturers instructions allowing the volume for the primary coil shown in the Table in 1.2 Technical Data.

POWERFLUSHING/CLEANING OF THE HEATING SYSTEM

If it is proposed to 'powerflush' the heating system we would recommend that the BoilerMate appliance is isolated from the heating system being cleaned. Failure to do this could seriously damage the appliance.

When carrying out the work always comply fully with the manufacturers instructions for the powerflushing equipment being used.

If in any doubt please consult our Technical Helpline.

2.0 INSTALLATION

2.3 COMMISSIONING

Once the system is finally filled turn down the servicing valve for the ballvalve in the F & E cistern, if fitted, to the point where the warning/overflow will cope with the discharge arising from a ballvalve failure.

If an overflow is not fitted check and ensure that any temporary filling connections are removed/comply with the Water Regulations.

Cleansing Hot/Cold Water System Treatment

Fully flush and if necessary chlorinate the hot and cold water system in accordance with the recommendations in the Model Water Byelaws and BS 6700.

Note: Incorrect chlorination will damage the plate heat exchanger so care must be taken that the system is fully flushed.

Commissioning the BoilerMate control system

For maximum system efficiency the store thermostat must be in control of the boiler i.e. the boiler cycles on the store thermostat and not on its integral thermostat. The BoilerMate control system will automatically commission itself to match the actual

performance of the installed boiler. However the operation of the control system should be checked as follows:

(a) Check that the BoilerMate front panel mode rocker is in the 'normal' position. Put the hot water control rocker in the constant position and the central heating control rocker in the off position.

(b) The boiler will not start i.e. there will be no 240V ac start signal at BoilerMate terminal 'SL-B' until:-

- The programmer calls for hot water /heating which will bring display segment V1.1 on, and
- Store sensors are calling for heat which will bring display segments H1.1 and H1.2 on (see opposite)

(c) Set the boiler thermostat to maximum and commission the boiler as per manufacturer's instructions and ensure that the flow temperature reaches more than 77°C before switching off. Display segments H2.3 and V2.1 will be on whilst the boiler is firing.

(d) Check and adjust the speed of the boiler pump to provide a differential temperature of about 11°C across the flow and return when the space heating is off.

(e) Check on the A.C.B. that the appliance reaches a suitable temperature ie above 75°C

(f) To manually check the 'switch' electric backup is working, move the mode rocker on front panel display from 'normal' to 'switch' position. The electric backup operation can now be checked. Draw a bath full of hot water from the appliance to lower the temperature and bring 'switch' into operation.

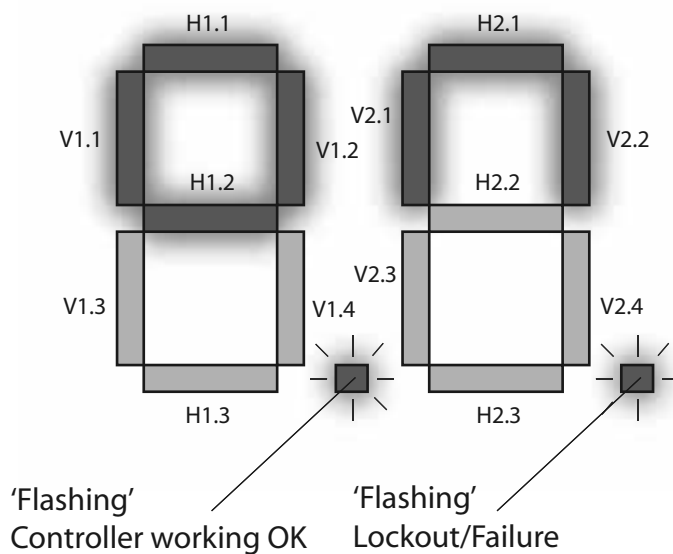

Note: If both 'dots' are flashing then the controller is working. However it is a warning of limited/alternative control functionality

LED	Description
H1.1	Middle store sensor calling for heat
H1.2	Bottom store sensor calling for heat
H1.3	Spare
V1.1	HW Programmer calling for heat
V1.3	CH Programmer calling for heat
V1.4	Room thermostat calling for heat
V2.3	3 port valve - mid position
V2.4	3 port valve - full divert (along with V2.3)
H2.1	PHE pump on
H2.2	3 port valve on (for heating)
H2.3	Boiler/heating system pump on
V2.1	Boiler on
V2.2	Switch on / electric boost on

This is easily checked with the aid of a clamp meter that should show a current drawn of around 26 amp. If a suitable meter is not available a bath full of hot water should be drawn from the appliance after which the store temperature should be noted. With no further demand a rise in store temperature of 5 – 10°C in about 15-20 minutes (dependent on store size) should be observed. Display segment V2.2 will be on whilst 'Switch' is working. Once it has been proved that 'switch' is working move the mode rocker switch back to the normal position.

2.3 COMMISSIONING

Commissioning Space Heating

(a) The central heating is best commissioned when the store is hot and therefore should be carried out after commissioning the BoilerMate.

(b) Move the central heating control rocker to the constant position, set heating programmer to continuous and ensure that the room thermostat is calling for heat. This will be indicated by display segments V1.3 and V1.4 being on respectively. The BoilerMate controller will now:-

- Open the 3 port valve to mid position to turn on the central heating. This will be indicated by display segment V2.3 being lit. Display segment H2.3 will be on and V2.1 will be on when the boiler is firing. In normal operation the store temperature will need to reach 57°C before the valve is allowed to operate.

Once the store is fully heated (normally 75°C) the 3 port valve will move over fully to the central heating position.

Note: The controller is set to give hot water priority and if the store temperature drops below 60°C the 3 port valve will move back to the hot water only position.

(c) Wait until the heating circuit has reached its normal temperature before balancing the system in the usual way to achieve a temperature drop of about 10°C.

(d) Set the programmer and room thermostat as per manufacturer's instructions supplied with the appliance and ensure that the programmer instructions along with the user instructions for the appliance are left with the user.

NOTE: With sealed heating systems air is released from the water during the first few weeks of operation. This must be vented and the system repressurized.

Commissioning Domestic Hot Water System

(a) When the store is hot, open a hot water tap nearest to the appliance at approximately 6 litres/minute. After about 2 – 3 seconds, the plate heat exchanger pump will start. This is indicated on the A.C.B. by display segment H2.1.

(b) The hot water flow temperature should settle at about 52°C. Close this tap and open the hot bath tap at maximum flow rate and record the flow rate and the hot water temperature in the 'Benchmark' logbook.

(c) Close the hot water tap(s) and after few seconds, the plate heat exchanger pump will stop running and display segment H2.1 will turn off.

NOTE: It is recommended that the hot water rocker is left on constant so that hot water is always available. The central heating rocker should be left on timed and the clock set to control the times heating is required.

Hand over to User

- Explain the system and the BoilerMate appliance controls to the user.
- Explain how to operate the heating and hot water controls to the user. This should include setting 'on' and 'off' times and the room temperature on the room thermostat as well as the use of thermostatic radiator valves.
- Advise on boiler operation and maintenance advised in the boiler manual.
- Explain how to select and check the operation of the emergency backup electric boiler 'switch operation' - if there is a failure of the boiler.
- Handover appliance and room thermostat user instructions and put the completed "Benchmark" logbook and the appliance instruction manual in the pocket on the inside of the appliance front panel.
- DON'T place any clothing or other combustible materials against or on top of this appliance.

This product is covered by the 'Benchmark' scheme and a separate commissioning/ service log book is included with this product. This must be completed during commissioning and left with the product to meet the Warranty conditions offered by Gledhill.

These Instructions should be placed along with the component manufacturers instructions in the pocket provided on the rear of the front panel. The front panel should then be refitted.

2.3 COMMISSIONING

Important Do's and Don'ts

DO check the incoming mains water pressure and flow rate are adequate. (The preferred range of mains pressure is 2-3bar).

DO check that all plumbing and electrical connections are in accordance with the labelling on the thermal store.

DO check and ensure the air pressure side of the expansion vessel is set at 1.0 bar (or as specified)

DO ensure the BoilerMate A-Class SP is fitted on a sealed primary (i.e. closed) system and the boiler is suitable (i.e. fitted with an overheat thermostat)

DO with automatic fill models adjust the ballvalve so that the water level in the appliance F & E cistern when the system is cold is correct and does not overflow when the appliance is at maximum temperature

DO with automatic fill models turn down the servicing valve for the ballvalve in the F & E cistern, once the system is finally filled, to the point where the warning/overflow pipe will cope with the discharge arising from a ballvalve failure.

DO check that the F & E cistern is not more than 6m above the base of the BoilerMate appliance.

DO with automatic fill models make sure that there is adequate clearance above the appliance F & E cistern to service the ballvalve.

DO ensure that the range rated appliances are set at the **highest output** and the boiler thermostat is set to **maximum** for all boilers.

DO insulate any exposed pipework in the BoilerMate A-Class SP cupboard.

DO plumb the overflow/warning pipe (if fitted) in a 20mm internal diameter pipe material which is suitable for use with a heating F & E cistern, in accordance with BS 5449 (such as copper) and ensure it has a continuous fall and discharges in a conspicuous external position.

DO check that the primary system pressure does not exceed 2 bar when the whole of the system is up to temperature.

DO check the pump settings

a. The boiler/heating pump should be set to give a temperature difference across the flow and return of not more than 11°C.

b. The hot water plate heat exchanger pump should be set at **maximum**.

DO ensure that the bypass valve for the heating system is set correctly.

DON'T use a combined feed and vent on BoilerMate A-Class installations.

DON'T use pipe smaller than 28mm between the boiler and the BoilerMate when the boiler rating exceeds 20kW (about 68,000 Btu/h).

DON'T operate the 'switch' backup facility until the system is fully fitted, vented and commissioned.

DON'T place any clothing or other combustible materials against or on top of this appliance.

3.0 SERVICING

3.1 ANNUAL SERVICING

No annual servicing of the BoilerMate A-Class is necessary.

However, if required, the operation of the controls and a hot water performance test can be carried out when servicing the boiler to prove the appliance is working satisfactorily and within its specification.

3.2 CHANGING COMPONENTS

Free of charge replacements for any faulty components are available from Gledhill during the in-warranty period (normally 12 months).

After this, spares can be obtained direct from Gledhill using the 'Speed Spares' service, or through any of the larger plumbers merchants/specialist heating spares suppliers.

Help and advice is also available from the Technical Helpline on 08449 310000.

However, all components are readily accessible and can be changed quickly and easily by the installer using common plumbing practice.

Note:

The PHE pump is a Grundfos UPR 4 wire type and any replacement must be the same model.

3.0 SERVICING

3.3 SHORTS PART LIST

Key No.	Description	Supplier/Components	Stock Code No	Models	Gas Council No.
1	PHE pump	Grundfos UPR 15-50 (modulating)	GT089	All	
2	Plate heat exchanger (PHE)	SWEP 24 Plate heat exchanger	GT017	All	
3	PHE pump isolating valve - inlet	Martin Orgee	GT133	All	
4	PHE pump isolating valve - outlet	Martin Orgee	GT135	All	
5	CW inlet Y-line strainer		XB314	AI	
6	Boiler/heating pump	Grundfos, UPS 15-60 (standard)	XB241	210, 225	
7	Boiler/heating pump isolating valves	Vemco - Inlet	XB121	125, 145, 185	
		Vemco - Outlet	XB121	125, 145, 185	
		Vemco, Inlet & Outlet	XB122	210, 225	
9	1 x 6 kW switch immersion heater	Wardtee	XB430-	All	
10	Main PCB controller	Pijenburg	GT490	All	
11	Bottom store sensor	Tasseron	GT198	All	
12	Middle store sensor	Tasseron	GT198	All	
13	Top (OHT) sensor	Tasseron	GT199	All	
14	Front panel display	R H Technical	XB414	All	
15	Front panel display wiring harness	R H Technical	XB057	All	
16	Internal fuses/circuit protection	MCB Single Pole 16A x 2	XG175	All	
		MCB Single Pole 6A x 1	XB025	All	
17	Switch contactor	Relay Base	XB299	All	
		Relay	XB298		
18	DIN Rail terminals	Wago	NSI	All	
19	Complete DIN rail assembly	Wago		All	
20	Complete wiring harness			All	
21	On-Off rocker	Arcoelectric	CA006	All	
22	Programmer EMC	Grasslin	XB215	All	
23	Central heating and hot water rocker	Arcoelectric	XB059	All	
24	DHW In/Out Sensor x 2	Tasseron	GT198	All	

3.4 FAULT FINDING

Despite everyone's best efforts some problems could occur and lead to complaints from the householder.

Complaints can be grouped into the following three main categories:-

1. The system is noisy
2. Hot water service is unsatisfactory
3. Space heating is unsatisfactory

The following checks should be carried out by the installer before calling the manufacturer.

1. Causes of a 'Noisy' System

Noisy pump operation

Check the level of water in the F & E cistern - adjust and vent the pump/system if necessary.

Check heating circuit pressure - fill it to 1.5 bar and vent if necessary.

Check the pump speed setting of the boiler/heating pump - reduce if necessary but ensure that the temperature rise across the system is about 11°C.

Check the operation of the 3 port valve.

Check and adjust if necessary the heating system bypass valve.

Check that the radiators are correctly balanced.

Noisy boiler operation

Check the flow rate through the boiler at full gas rate by measuring the temperature rise across the boiler. If the temperature rise is greater than 11°C, then increase the pump speed.

Check system pressure, top up the expansion vessel - and vent if necessary.

Check and vent the system if necessary.

Noise when hot water tap is opened

If the plate heat exchanger pump is noisy when the hot water tap is opened, then check the level of water in the F & E cistern and vent the pump if necessary.

Water hammer - loose pipework and/or tap washers.

2. Causes of 'Unsatisfactory Hot Water Service'

Check that the BoilerMate is full of water i.e. level of water in the F & E cistern is correct when system is cold.

Check boiler thermostat - this should be set at maximum.

Check that the boiler flow temperature is adequate when it stops firing. Boilers should provide a flow temperature of $82 \pm 3^\circ\text{C}$ but temperatures as low as 75°C will allow the BoilerMate A-Class to provide a satisfactory performance.

Check that the store is charging to at least 75°C .

Check that the hot water plate heat exchanger pump stops and starts when the hot water tap is opened and closed.

Check that the plate heat exchanger pump is set at maximum speed.

Check that the space heating and hot water load is not greater than the boiler output and that the BoilerMate A-Class model is suitable for the type of dwelling.

If all the above checks are satisfactory then it is possible that the performance of the heat exchanger is impaired by scale. In this case the hot water flow rate will be noticeably less than the cold water flow rate. Replace with a factory exchange unit and re-check hot water performance.

3. Causes of 'Unsatisfactory Space Heating'

Check the boiler thermostat - this should be set at maximum.

Check that the boiler flow temperature before it is turned off by its own internal thermostat or the store sensor is adequate - it should not be less than 77°C .

Check the operation and the settings of the heating programmer and the room thermostat.

Check that the boiler/heating system pump is working and the 3 port valve is allowing water to the radiator circuit.

If some rooms are not being heated properly, then balance the system/check the operation of the thermostatic radiator valves (if fitted).

Overflow from Feed and Expansion Cistern

Check that the controlled level of water in the cistern is no higher than necessary. Adjust if required.

POWERFLUSHING/CLEANING OF THE HEATING SYSTEM

If it is proposed to 'powerflush' the heating system we would recommend that the BoilerMate appliance is isolated from the heating system being cleaned. Failure to do this could seriously damage the appliance.

When carrying out the work always comply fully with the manufacturer's instructions for the powerflushing equipment being used.

If in any doubt please consult our Technical Helpline.

Note: If the A.C.B. board is replaced it will need setting to the appliance type - see page 10 for further details.

The system controls/operation should then be checked.

If the problem cannot be resolved the switch emergency electric backup should be switched on and operated in accordance with the instructions on the label fitted to the appliance until the installer/manufacturer can attend.

When requesting a visit from the manufacturer the installer must have the completed 'Benchmark' commissioning/service record sheet to hand to enable help to be provided.

WATER SAVINGS

WATER RELATED COSTS CAN BE REDUCED BY GOOD PLUMBING PRACTICE.

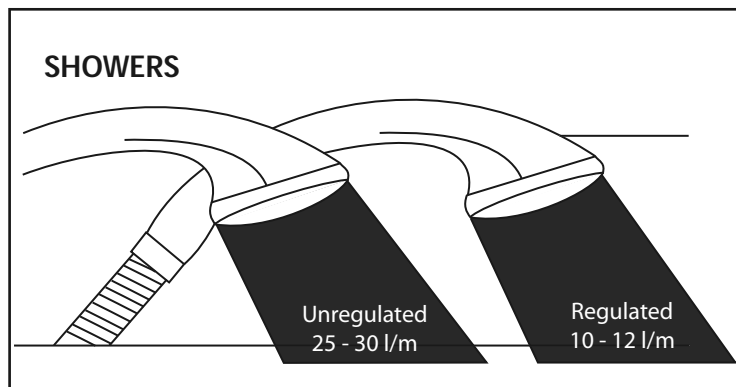
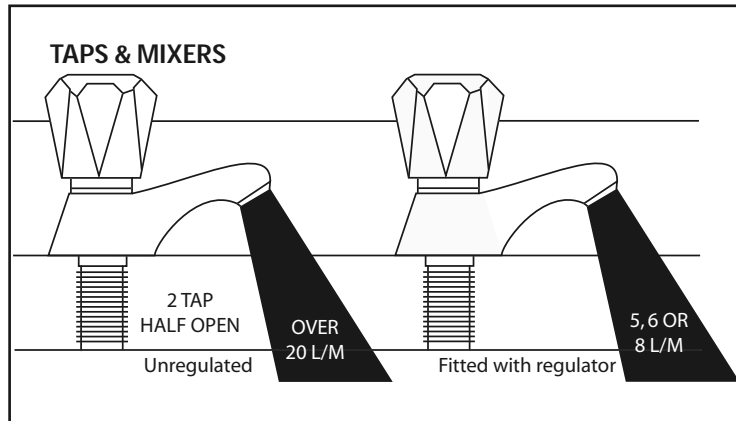

Vast quantities of water are needlessly run off to waste due to Taps, Mixers and Showers discharging flow rates far in excess of the rates required for them to perform their duties.

The contrasting flow rates shown on this leaflet clearly illustrate the savings that can be made whilst still providing a good performance.

British made Aquaflow Regulators provide constant flow rates by automatically compensating for supply pressure changes between 1 bar & 10 bars.

To facilitate installation into the wide range of plumbing equipment which is encountered in the U.K, Four Fixing Options are available:-

OPTIONS FOR SHOWERS

1. MXF "DW" Range - For fitting behind Fixed Shower Heads or onto Flexible Hoses for Handshowers (preferably onto the inlet end when lightweight hoses are used).
2. Compression Fitting Range. "In Line" regulators as in Option 4 for Taps & Mixers.

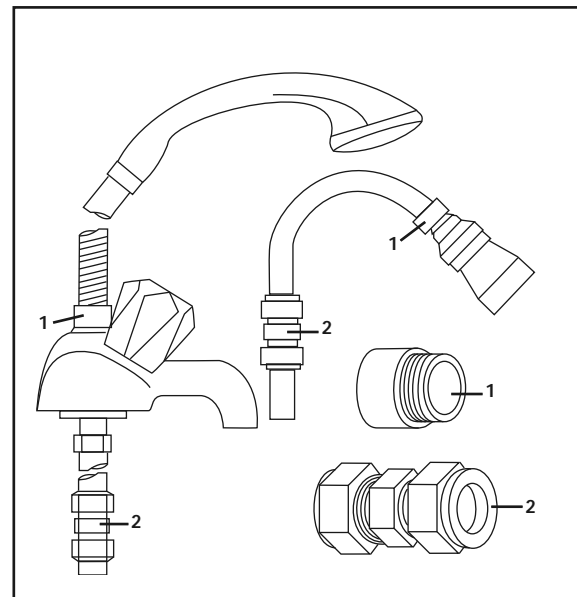

4 FIXING OPTIONS FOR TAPS & MIXERS

1. MK Range - Combined Regulators & Aerator for screwing onto Taps & Mixers with internal or external threads on their noses. Anti Vandal models also available.
2. MR05-T Range - Internal Regulators. Push-fit into Tap or Mixer seats. Produced in three sizes - 12.5mm (BS1010), 12mm & 10mm, Flangeless models also available for Taps with Low Lift washers.
3. MXF Standard Range - Screw on tail models for Taps & Mixers. Fix onto the tails before fitting the tap connectors. Available in 3/8", 1/2", 3/4" and 1" BSP.
4. Compression Fitting Range - "In Line" regulators housed in 15mm & 22mm CXC Couplers & Isolating Valves. "UK WFBs listed by the Water Research Centre. Isolation valves available for slotted screwdriver operation or with coloured plastic handles. Now available also in plastic bodied push-fit couplers & valves.

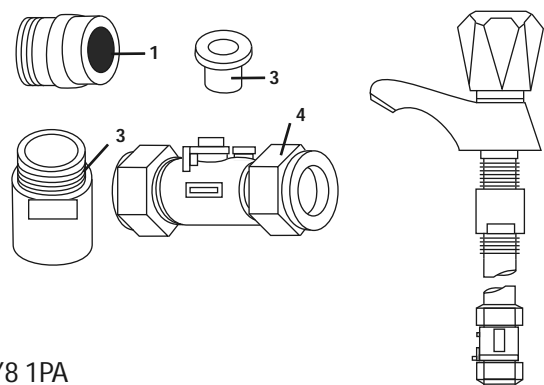

Information by courtesy of

AQUAFLOW REGULATORS LTD

Haywood House, 40 New Road, Stourbridge, West Midlands DY8 1PA
TELEPHONE (01384) 442611 FAX: (01384) 442612

APPENDIX B

MANIFOLDS

Manifold type: 1 - Stock Code MIP 050 (one bathroom, one en suite shower room, one cloakroom, one kitchen)			
Flow regulator (litres/minutes)	Terminal fitting	Hot water manifold outlets Quantity	Cold water manifold outlets Quantity
18	Bath tap	1	1
9	Hand basin	3	3
12	Kitchen sink	1	1
9	Toilet cistern	None	3
9	Shower	1	1
12	Washing machine	1	1
9	Dishwasher	None	1
	Total	7	11

Two sets of manifolds are available as an optional extra. Each set comprises a separate hot and cold water manifold. Both are provided with a 22mm inlet connection located centrally. All outlet connections are 15mm compression. The centre to centre dimension of each branch is 55mm.

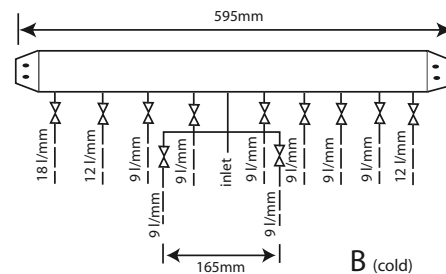
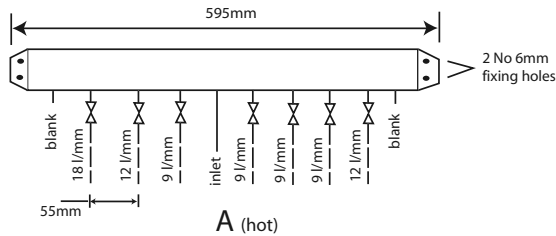

Manifold type: 2 - Stock Code MIP 060 (two bathrooms, one en suite shower room, one cloakroom, one kitchen, one utility room)			
Flow regulator (litres/minutes)	Terminal fitting	Hot water manifold outlets Quantity	Cold water manifold outlets Quantity
18	Bath tap	2	2
9	Hand basin	4	4
12	Kitchen sink	2	2
9	Toilet cistern	None	4
9	Shower	1	1
12	Washing machine	1	1
9	Dishwasher	None	1
	Total	10	15

The arrangement of each manifold is supplied as shown. This provides the best balance of flows but the flow regulators/duty of each branch can be changed if required as long as a reasonable balance is maintained. If it is necessary to change or clean the flow regulator this can be done without needing to drain the system by closing the valve and removing the screwed cover below the white plastic cover.

The manifolds are designed to be used with plastic pipework and are supplied complete with isolation valves and flow regulators on each branch. They would normally be installed in the same cupboard as the thermal storage appliance (as shown below) but can be installed in another cupboard close to the appliance if required.

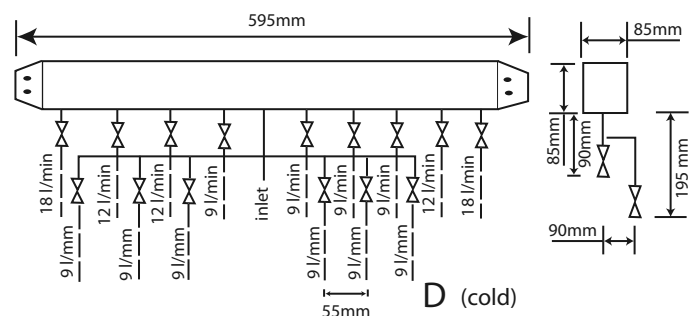
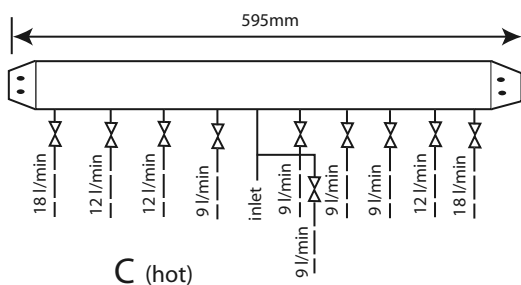

APPENDIX B

An optional location where cupboard space is tight



The pressure loss through a flow regulator at the designated flow rate is about 1.8 bar. Therefore for the flow regulator to control the flow rate at pre-set level, the inlet pressure must be greater than 1.8 bar. If the inlet pressure is lower, the flow rate will be correspondingly less than the pre-set values.

The maximum equivalent pipe lengths from the manifold to the terminal fittings can be estimated from the above information and the resistance characteristics of the pipes. The examples presented below are for 15mm copper pipe in table 1 and for plastic pipework in table 2.



The preferred solution where space will allow

Table 1: Maximum equivalent pipe length in 15mm copper

Inlet pressure (bar)	Maximum equivalent length of pipe (m)		
	@ 9 l/m	@ 12 l/m	@ 18 l/m
2.0	25	10	5
2.5	75	30	15
3.0	150	60	30

Table 2: Maximum equivalent pipe length in plastic pipe

Inlet pressure (bar)	Maximum equivalent length of pipe (m)		
	@ 9 l/m	@ 12 l/m	@ 18 l/m
2.0	1.5	15mm : 10	15mm : 4.5 22mm : 40
2.5	3.0	15mm : 20	15mm : 9.0 22mm : 80.0
3.0	4.5	15mm : 30	15mm : 13.5 22mm : 120

APPENDIX B

The size of the distribution pipes supplying the manifold should be calculated using the method set out in BS 6700. A typical diagrammatic arrangement of a system using Manifold Type 1 is shown below. This is only meant to show the principles involved and the actual connection of fittings to the manifold will need to suit the arrangements shown on page 35.

Note 1 - If it is proposed to fit chemical water treatment such as a water softener this should be fitted in this location and the cold water branch in the sink should be branched off the cold water main prior to the treatment device instead of the cold water manifold.

Any other isolating/control valves and backflow protection devices should be provided as necessary to comply with the Water Regulations.

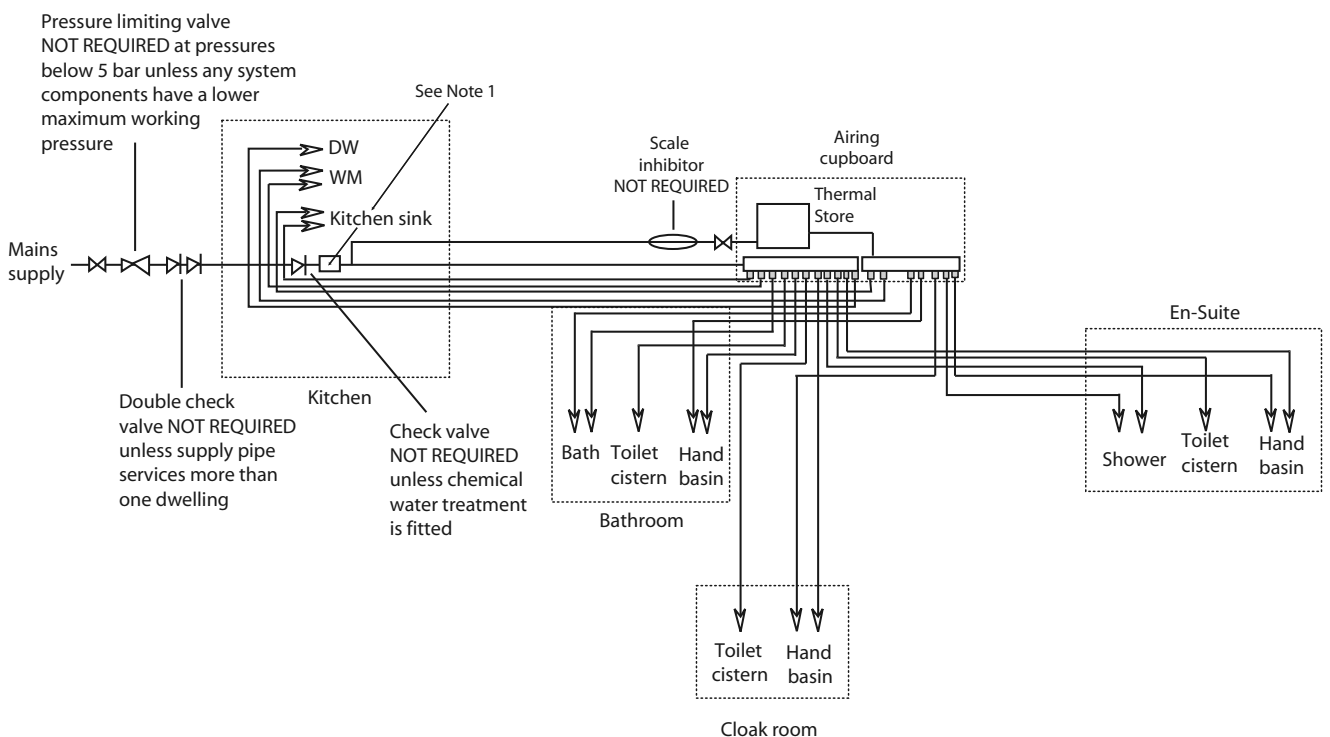



2 Inhibitor (Corrosion & scale protection of primary heating circuit)

On filling the heating system and before the boiler is fired up, it is important to ensure the system water is treated with a suitable corrosion inhibitor, in accordance with the boiler manufacturer's instructions.

Since the concentration of inhibitor present in a system can become diluted, for a number of different reasons, the system should be checked annually and re-treated as required, or after every full or partial drain-down. A water treatment manufacturer's test kit may be used to check the correct concentration of inhibitor in the system.

Where recommended by a boiler manufacturer, a 'physical corrosion protection device' may be fitted in the primary pipework in accordance with the boiler manufacturer's instructions.

The Benchmark log book should be completed indicating the date and details of any of the above products added and a permanent label should be fixed to the system in a prominent location.



3 Scale protection (Domestic hot water service)



Where a combi boiler and/or a hot water storage vessel is installed in areas where the mains water can exceed 200ppm Total Hardness (as defined by BS 7593: 1993 Table 2) a scale reduction device should be installed, in accordance with the boiler manufacturer's instructions.

The levels of water hardness may be measured using a water hardness test kit.

BUILDING REGULATIONS

Completion of the BENCHMARK log book requires that the 'competent person' undertaking the installation and commissioning provide information relating to Cleaning, Inhibitor and Scale Protection. This will demonstrate that the work complies with the requirements of the appropriate Building Regulations.

This Guidance Note is produced on behalf of its members by the Central Heating Information Council. For a full list of members visit www.centralheating.co.uk and for further advice on water treatment contact the following members:

 Culligan  Sentinel  Feroxx  Salamander Engineering  Scalemaster

Heating & Hotwater Information Council, 36 Holly Walk, Leamington Spa,
Warwickshire CV32 4LY Tel: 0845 600 2200 Fax: 01926 423284
www.centralheating.co.uk



Benchmark is managed by The Heating & Hotwater Information Council

MANUAL HANDLING OF APPLIANCE PRODUCTS

Description

Manual handling means any transporting or supporting of a load (including lifting, putting down, pushing, pulling, carrying or moving) by hand or bodily force.

Scope

This assessment will cover the largest Appliance, namely ElectraMate, GulfStream, BoilerMate, SysteMate, PulsaCoil, Accolade and Stainless Lite manufactured by Gledhill.

The maximum weight of the largest product in each range is 98kg and the size is 595 x 595 x 2020 mm high.

Main Hazards

Vision may not be clear due to the size of the products. Adopting an incorrect method of lifting may cause injury, attempting to lift these products will require help from others. (Team lifts)

Control Measures

Manual lifting procedure

The lift, key factors in safe lifting are:

- a. **Balance**
- b. **Position of back**
- c. **Positioning of the arms and body**
- d. **The hold**
- e. **Taking the lead for team lifts**

- a. **Balance** - Since balance depends essentially upon the position of the feet, they should be apart about hip breadth with one foot advanced giving full balance sideways and forward without tension. In taking up this position, lifting is done by bending at the knees instead of the hips and the muscles that are brought into use are those of the thigh and not the back.
- b. **Position of back** - Straight - not necessary vertical. The spine must be kept rigid, this coupled with a bent knee position, allows the centre line of gravity of the body to be over the weight so reducing strain.
- c. **Positioning of arms and body** - The further arms are away from the side, the greater the strain on the shoulders, chest and back. Keep elbows close to the body arms should be straight.
- d. **The hold** - Before lifting ensure you have a good hold. Two handles are provided on Appliance products at the top rear side, these allow one or two persons to have a purposely-designed hold at the top of the appliance to ensure easy lifting at the top of the product. Each appliance is supplied with a pallet, which has been attached to the unit via the packaging. The pallet will also allow for one or two persons to get a good hold.

- e. **Taking the lead for team lifts**- As more than one person is required for these products ensure that one person is taking the lead. **This may be you** so ensure that each person that is helping is made aware of the weight and of the items listed within this assessment. Make sure you and any others helping know the route you intend to take that it is clear of any obstructions. Never jerk the load as this will add a little extra force and can cause severe strain to the arms, back and shoulders. If there are steps involved decide on where you will stop and take a rest period. Move smoothly and in unison taking care to look and listen to others helping with the lift. Where possible use a sack truck to move the product over long flat distances, only lift the products when necessary. If in doubt stop and get more help. The unit handles and packaging with the pallet have been designed to ensure that two-four people can assist when lifting up stairs or over longer distance.

Individual capability

Individual capability plays an important part in handling these products. Persons above average build and strength will find it easier and should be in good health. Persons below average build and strength may require more rest periods during the handling process. Pregnant women should not carry out this operation. Persons who are not in good health should seek medical advice prior to commencing any lifting or manual handling operation.

Residual risk

Following the guidelines given above will reduce any risk to injury. All persons carrying out this operation must be fully trained and copies of the specific risk assessment made available for inspection and use in their training process.

Further guidance on Manual Handling can be obtained from the Health and Safety Executive. Manual Handling Operations Regulations 1992.

Gledhill (Water Storage) Ltd

AMD, JUNE 2008

CONDITIONS OF SALE & GUARANTEE TERMS

1. Gledhill (Water Storage) Ltd ("We" or "Gledhill") only do business upon the Conditions which appear below and no other. Unless we so agree in writing these Conditions shall apply in full to any supply of goods by us to the exclusion of any Conditions or terms sought to be imposed by any purchaser. These Conditions of Sale and Warranty Terms exclude those which are contained on the Invoice Form and all Sales are made subject to these Conditions of Sale and Warranty Terms only.

2. PRICE

Once an order or call off has been accepted the price will be held for three months but if delivery is estimated beyond that period at the customer's request, then we reserve the right to amend the price when necessary. The company reserves its pricing flexibility to adjust for changes in material costs. We reserve the right to alter price as at any time for severe movements in raw materials (notably copper and steel). If there is to be a change we will give customers at least four weeks notice but anything delivered after that date will be at the revised price. An order may not be cancelled or varied after acceptance without the written consent of the company. Such cancellations or variations shall be subject to such reasonable charges as may be appropriate.

3. SPECIFICATION

The goods are supplied in accordance with the Specifications (if any) submitted to the Purchaser and any additions and alterations shall be the subject of an extra charge. Any goods not so specified shall be in accordance with our printed literature or the literature of any of our component suppliers subject to any modifications made there published. If we adopt any changes in construction or design of the goods, or in the specifications published in our literature, the Purchaser shall accept the goods as changed in fulfillment of the order.

4. PAYMENT

The Invoice price of goods shall be payable within 30 days of dispatch by us of our Invoice for the goods or such longer time as may be stated by our quotations or Invoices. If we receive payment in full or before the due date we will allow an appropriate discount unless advised in writing you have spotted a special net price. If payment is not received in full or before the due date we shall be entitled in addition to the Invoice price to:

- (i) payment of a sum equal to any increase in the copper price supplement applicable to the particular goods sold between the date of receipt of order and the date of receipt of payment in full; and
- (ii) interest on any part of the Invoice price unpaid after the due date at the rate of 3% per annum over the base rate for the time being of HSBC Bank plc.

5. TITLE

We give estimates of delivery dates in good faith and time of delivery is not set shall be made of the nature of any contract nor shall we be liable for any loss or damage sustained by delay in delivery.

6. DELIVERY

We deliver our goods usually by our own vehicles within 25 miles of any of our manufacturing depots. Delivery to any place more than 25 miles from one of our manufacturing depots may be subject to our special delivery charges. We reserve the right to make delivery of goods contained in one order by more than one consignment and at different times. Where a period is agreed for delivery and such period is not observed by our Agreement, the Purchaser shall take delivery within that period. If the Purchaser fails to take delivery, we shall be entitled at the Purchaser's risk and expense to store the goods at the Purchaser's premises or elsewhere and to demand payment as if they had been despatched. Off loading at point of delivery shall be the responsibility of and to undertaken by the Purchaser.

7. WARRANTIES OR GUARANTEES

Goods will be inspected before dispatch of delivery notes and any damage, shortage or discrepancy noted on the delivery notes and the goods returned on the same vehicle. The buyer must also give us immediate written notice of the damage, shortage or discrepancy so that we may prompt investigations.

8. RETURN OF GOODS

Goods may not be returned to the Company except by prior written permission of an authorized officer of the Company and such return shall be subject to payment by the Purchaser of handling and re-stocking charges, transport and all other costs incurred by the Company.

9. COMPANY LIABILITY AND GUARANTEE

9.1. Subject to the terms of these Conditions of Sale and General or Terms Gledhill provides Guarantees in respect of specific products as set out in this clause.

9.2. Each Guarantee is strictly conditional upon the following:

9.2.1. Complaints must be given to us immediately, before any action is taken, as responsibility cannot be accepted if spares or materials are attempted on site without our written approval.

9.2.2. The unit has been installed in accordance with manufacturer's and service instructions and all relevant codes of practice and regulations in force at the time of installation.

9.2.3. All necessary inlet controls and safety valves have been fitted correctly.

9.2.4. The unit has only been used for the storage of potable water supplied from the public mains.

9.2.5. Where appropriate the unit has been regularly maintained as detailed in the installation and service instructions.

9.2.6. Defects caused by corrosion or scale deposits are not covered by any Guarantee.

9.2.7. Where we agree to modify any detail we reserve the right to undertake the work on our own premises.

9.3. Guarantees are provided in respect of specified goods supplied by Gledhill as follows:-

(a) Domestic and Commercial Open Venting Cylinders and Tanks.

The copper storage vessel is guaranteed for ten years and if it proves to be defective either in materials or workmanship, we will either repair or supply replacement at our option with the direct substitute in the case of any obsolete product to any address in Great Britain.

(i) Free of all charges during the first year after delivery by us.

(ii) Thereafter at a charge of one-tenth of the then current list price and any copper price supplement and delivery charge during the second year after delivery by us and increasing by a further one-tenth on the second and subsequent anniversary of delivery by us.

(a) Domestic Hot Water Products (Pressureless)

The copper storage vessel is guaranteed for five years and if it or any integral pipework as part of the storage vessel becomes defective in materials or workmanship, we reserve the right to either repair or supply replacements or the closest possible substitute in the case of any obsolete product and will collect and deliver to any address in England, Wales and Scotland (including all Scottish islands).

(i) Free of all charges during the first year after delivery by us.

(ii) Thereafter at a charge of one-fifth of the then current list price or any copper price supplement and delivery charge during the second year after delivery by us increasing by a further one-fifth on the second and subsequent anniversary of delivery by us.

(a) Integrated Inlet and Storage Tank Products and Stand Alone Inlet

In the case of the full range of products and the Gledhill Inlet range of products, Gledhill guarantees as the best manufacturer (Gledhill) for materials and construction faults for two years. THE RESPONSIBILITY FOR THE EXECUTION OF THIS GUARANTEE LIES WITH THE INSTALLER.

The guarantee becomes null and void if the appliance is used incorrectly, or in the event of proven negligence or incorrectly implemented repairs OR FAILURE TO CHECK OUT THE RECOMMENDED INSPECTION/MAINTENANCE. The guarantee also becomes null and void if changes are made to the appliance without our knowledge, or if the total number on the appliance is exceeded or scale buildup.

The annual service must be carried out by a competent installer in accordance with the advice given by Gledhill and using Gledhill approved parts.

(b) Hot Water Heat Exchanger Cylinders
Gledhill guarantees the components including gaskets, valves and electrical parts for two years from the date of purchase. IT SHOULD BE NOTED THAT THE FACTORY FITTED TEMPERATURE AND PRESSURE RELIEF VALVE MUST NOT BE REMOVED OR ALTERED IN ANY WAY OR THE GUARANTEE WILL NOT BE VALID. GLEDHILL WILL NOT BE RESPONSIBLE FOR ANY CONSEQUENTIAL LOSS OR DAMAGE HOWEVER IT IS CAUSED.

The guarantee for the stainless steel vessel is for twenty five years if the unit is returned to us **UNMODIFIED**:-

(i) It has been installed as per the Design, Installation & Servicing Instructions, relevant standards, regulations and codes of practice.

(ii) It has not been modified other than by Gledhill.

(iii) It has not been subjected to misuse or improper use or full removal for.

(iv) It has only been used for the storage of potable water.

(v) It has not been subjected to fire damage.

(vi) The benchmark log book is completed after each annual service.

(vii) The unit has been serviced annually.

It should be noted that the guarantee does not cover:-

- the effects of scale build up
- any labour charges associated with replacing the unit or parts.

If the stainless steel vessel proves to be defective either in materials or workmanship we reserve the right to either repair or supply replacements or the closest possible substitute in the case of any obsolete product and will collect and deliver to any address in England, Scotland and Wales (including all islands).

(i) Free of charge during the first year after delivery by us.

(ii) Thereafter at a charge of one-tenth of the then current list price during the second year after delivery by us and increasing by a further one-tenth fifth on the second and subsequent anniversary of delivery by us.

10. ACTION IN THE EVENT OF FAILURE

If the stainless steel cylinder develops a leak we will either a) replace or repair the supply of a new one. This will be intended if the failure is within the term of the warranty when it has been accepted by us.

(b) Solar Panels and auxiliary equipment

Gledhill provides a five year warranty for defects in the collector (except broken glass and collector accessories as noted above). If the collector demonstrably fails to meet one of the requirements of the standard BS1497 part 3 we will replace it free of charge based on the date of invoice. We can not be responsible for damage caused by mechanical stress and/or changes caused by weather related influences. The warranty excludes other surface damage that does not affect performance or malfunction due to improper assembly or installation.

11. Please note

- Installation must have been carried out by a licensed specialist company (installing contractor or plumber) following the written installation instructions in force.

- Gledhill or its representative may give the opportunity to check compliance on site immediately after any defect occurred.

- Installation valid that the system was commissioned properly and that the system was checked and maintained was performed annually by a specialist company licensed for this purpose.

(c) Components of our products other than Storage Vessels and Inlet Pipework.

We will either repair or replace the same items of warranty as we are given by the manufacturer of the component or if the manufacturer does not give any warranty, replace free of charge any component which becomes defective within five years after the date of the delivery by us and is returned to us at the purchaser's expense but we shall not meet the cost of removal or shipping or return of the component or any other cost charges or damage incurred by the purchaser.

If the appliance manufactured by Gledhill incorporates a factory fitted scale inhibitor then during the period

of these goods from the date of delivery. Goodwill will replace, free of charge, any plate heat exchanger fitted to the appliance as original equipment in which a coil has become so scaled that materially reduces the effectiveness of the plate heat exchanger. This guarantee does not extend to any other component installed within the Goodwill appliance or elsewhere in the Purchaser's domestic water system.

9.4.

9.4.1. In respect of goods supplied by us and in respect of any installation work carried out by or on our behalf, our entire liability and the purchaser's sole remedy (subject to the Guarantee) shall be as follows:-

- (1) We accept liability for death or personal injury to the extent that it results from our negligence or that of our employees.
- (2) Subject to the other provisions of this clause 9 we accept liability for direct physical damage to tangible property to the extent that such damage is caused by our negligence or that of our employees, agents or sub-contractors.
- (3) Our total liability to the purchaser over and above any liability to replace under the Guarantee (whether in contract or in tort including negligence) in respect of any one cause of loss or damage claimed to result from any breach of our obligations hereunder, shall be limited to actual money damages which shall not exceed £25,000 provided that such monetary limit shall not apply to any liability on the part of ourselves referred to in paragraph (1) above.
- (4) Except as provided in paragraph (1) above but otherwise notwithstanding any provision herein contained in no event shall we be liable for the following loss or damage to ourselves caused and over if these results by us or in our contemplation:
 - (a) economic loss which includes loss of profits, business revenues, goodwill or anticipated savings;
 - (b) damage in respect of special interest or consequential loss or damage (other than death, personal injury and damage to tangible property);
 - (c) any claim made against the purchaser by any other party (save as expressly provided in paragraph (1) above).
- (5) Except in respect of our liability referred to in paragraph (1) above we shall not be made or action brought (whether in contract or in tort including negligence) by the purchaser in respect of any goods supplied by us more than one year after the date of the incident for the relevant goods.
- (6) Without prejudice to any other term we shall not be liable for any water damage caused directly or indirectly as a result of any leak or other defect in the goods. We cannot control the conditions of use of the goods or the time or manner or location in which they will be installed and the purchaser agrees to be fully responsible for testing and checking all vessels which include the goods at all relevant times (as far as, including and after commissioning) and for taking all necessary steps to identify any leaks and prevent any damage being caused thereby.
- (7) Nothing in these Conditions shall confer on the purchaser any rights or remedies in which the purchaser would not otherwise be legally entitled.

10. LIMIT OF REMEDY

Notwithstanding any other provision contained herein the purchaser hereby agrees to fully indemnify us against any damage, losses, costs, claims or expenses incurred by us in respect of any claim brought against us by any third party (as:-

- (1) any loss, injury or damage wholly or partly caused by any goods supplied by us or their use;
- (2) any loss, injury or damage wholly or partly caused by the defective installation or substantial non-compliance or maintenance used in the installation of any goods supplied by us;
- (3) any loss, injury or damage in any way connected with the performance of this contract;
- (4) any loss resulting from any failure by the purchaser to comply with its obligations under these terms as to testing and/or check vessels correctly.

PROVIDED that this paragraph will not require the purchaser to indemnify us against any liability for our own acts of negligence or those of our employees or agents or sub-contractors.

FURTHER in the case of goods supplied by us which are re-sold and installed by a third party by the purchaser it will be the sole responsibility of the purchaser to test the goods immediately after their installation to ensure that later alterations are correctly installed and in proper working order free from leaks and are not likely to cause any loss, injury or damage to any person or property.

11. VARIATION OF WARRANTY AND EXCLUSIONS

Should our warranty and exclusion be unacceptable we are prepared to negotiate for variation in their terms but only on the basis of an increase in the price to allow for any additional liability or risk which may result from the variation.

Purchasers are advised to insure against any risk or liability which they may incur and which is not covered by our warranty.

12. FORCE AND EFFECT OF TITLE

- (1) Goods supplied by us shall be at the Purchaser's risk immediately upon delivery to the Purchaser or into custody on the Purchaser's behalf or to the Purchaser's Dealer. The Purchaser shall effect adequate insurances of the goods against all risks in the full invoice value of the goods, such insurances to be effective from the time of delivery until property in the goods shall pass to the Purchaser as hereinafter provided.
- (2) Property in the goods supplied hereunder will pass to the Purchaser when full payment has been made by the Purchaser to us (i.e.:-
 - (a) the goods of the subject of this contract;
 - (b) all other goods the subject of or of any other contract between the Purchaser and us which, at the time of payment of the full price of the goods sold under this contract, have been delivered to the Purchaser but not paid for in full.
- (3) Until property in the goods supplied hereunder passes to the Purchaser in accordance with paragraph (2) above:
 - (a) the Purchaser shall hold the goods in a fiduciary capacity for us and shall store the same separately from any other goods in the Purchaser's premises and in a manner which enables them to be identified as our goods;
 - (b) the Purchaser shall immediately return the goods to us should our authorized representatives so request. All the necessary incidents associated with a fiduciary relationship shall apply.
- (4) The Purchaser's right in possession of the goods shall cease forthwith upon the happening of any of the following events, namely:-
 - (a) if the Purchaser fails to make payment in full for the goods within the time stipulated in clause 4 hereof;
 - (b) if the Purchaser, not being a company, commits any act of bankruptcy, makes a proposal to its or her creditors for a compromise or does anything which would entitle a petition for a Bankruptcy Order to be presented;
 - (c) if the Purchaser, being a company, does anything or fails to do anything which would entitle an administrator or an administrative receiver or a receiver to take possession of any assets or which would entitle any person to present a petition for winding up or to apply for an administration order.
- (5) the Purchaser hereby grants to us an irrevocable licence to enter at any time any vehicle or premises owned or occupied by the Purchaser or in the possession of the Purchaser for the purposes of representing and

recovering any such goods the property in which has devolved in us under paragraph (2) above. We shall not be responsible for and the Purchaser will indemnify us against liability in respect of damage caused in any vehicle or premises in such representation and removal being damaged which it was not reasonably practicable to avoid.

- (6) notwithstanding paragraph (5) hereof and subject to paragraph (7) hereof, the Purchaser shall be permitted to sell the goods to third parties in the normal course of business. In this regard the Purchaser shall act in the capacity of our commission agent and the proceeds of such sale:-
 - (i) shall be held in trust for us in a manner which enables such proceeds to be identified as such; and
 - (ii) shall not be mixed with other monies nor paid into an overdraft bank account.

We, as principal, shall reimburse the Purchaser as commission agent a commission depending upon the amount which the Purchaser can obtain over and above the sum stipulated in this contract of supply which sells ability to:-

- (7) in the event that the Purchaser shall not any of the goods provided to clause (6) hereof, the Purchaser shall indemnify us in writing of such sale and of the identity and address of the third party to whom the goods have been sold;
- (8) if, before property in the goods passes to the Purchaser under paragraph (2) above the goods are or become affixed to any land or building owned by the Purchaser it is hereby agreed and declared that such affixation shall not have the effect of passing property in the goods to the Purchaser. Furthermore if, before property in the goods shall pass to the Purchaser under paragraph (2) hereof, the goods are or become affixed to any land or building (whether or not owned by the Purchaser), the Purchaser shall:-
 - (i) ensure that the goods are capable of being removed without material injury to such land or building;
 - (ii) take all necessary steps to prevent title to the goods from passing to the landlord of such land or building;
 - (iii) indemnify us in writing of such affixation and of the address of the land or building concerned.

The Purchaser warrants to repair and make good any damage caused by the affixation of the goods to or their removal from any land or building and to indemnify us against all loss, damage or liability so any land or certain as a result of affixation or removal.

- (9) in the event that, before property in the goods has passed to the Purchaser under paragraph (2) hereof, the goods or any of them are lost, stolen, damaged or destroyed:-
 - (a) the Purchaser shall indemnify us in writing of the fact and circumstances of such loss, theft, damage or destruction;
 - (b) the Purchaser shall assign to us the benefit of any insurance claims in respect of the goods so lost, stolen, damaged or destroyed.

13. NON-PAYMENT

If the Purchaser shall fail to make full payment for the goods supplied hereunder within the time stipulated in clause 4 hereof or he is default of payment for any other account then, without prejudice to any of our other rights hereunder, we shall be entitled to stop all deliveries of goods and materials to the Purchaser, including deliveries or further deliveries of goods under this contract. In addition we shall be entitled to terminate all outstanding orders.

14. VALUE ADDED TAX

All prices quoted are exclusive of Value Added Tax which will be charged at the rate ruling at the date of dispatch of invoices.

15. WHOLESALE ONLY

We are only prepared to deal with those who are not consumers within the terms of the Unfair Contract Terms Act 1977, the Sale of Goods Act 1979 and the Supply of Goods and Services Act 1982. Accordingly any person who purchases from us shall be deemed to have represented that he is not a consumer by so purchasing.

16. JURISDICTION

The agreement is subject to English law for purposes defined in England and Scottish law for purposes defined in Scotland and any dispute hereunder shall be settled in accordance therewith dependent upon the location.

